

# 71030i DC-DC CONVERTER INSTALLATION INSTRUCTIONS

1. It is recommended that the batteries be disconnected prior to installation. Reconnect the batteries after the installation is complete
2. Mount converter in a convenient, well ventilated area. Use 16AWG wire with a voltage rating of at least 150V to connect to power source. Use 14AWG for the ground and 12V outputs.
3. Terminal #4, #5, and #6 (“GND 12V”): Make ground connections first. Using 14AWG all three pins must be used for ground connection.
4. Terminal #7 and #8 (“SW 12V”): Using 16AWG connect both pins to 12V loads. These pins are switched On/Off with activation of Ignition, Terminal #3.
5. Terminal #3 (“IGN”): Using 16AWG connect to a switched 12V source. For always ‘ON’ operation this pin can be connected directly to 12V source.
6. Terminal #9 and #10 (“UNSW 12V”): Using 14AWG connect both pins to 12V loads. These terminals supply continuous 12V power.

**NOTE: THE SUM OF TWO OUTPUT LOADS (12V SWITCHED AND 12V UNSWITCHED) CANNOT EXCEED 30 AMPS.**

7. Terminal #12 (“72Vin, 80Vin, 96Vin”): Using 16AWG with a minimum rating of 150V, connect to positive terminal of power source.
8. Terminal #1 (“GND POWER SOURCE”): Using 16AWG with a minimum rating of 150V, connect to negative terminal of power source.

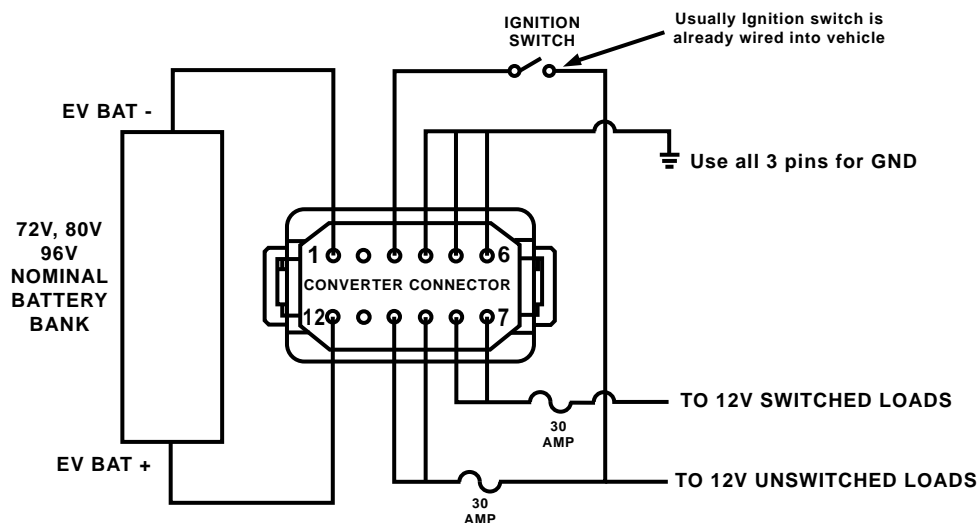

**TYPICAL INSTALLATION WITH SWITCHED & UNSWITCHED LOADS**  
(Total load must be less than 30A)