



INSTRUCTIONS

Product: GEM Electric Motorcars

Models: All

Subject: Instructions for Removing and Installing New Wiper Arm For Vehicles With Wiper Arms coming loose

Effected V.I.N. Range:

ONLY VEHICLES WITH WIPER ARMS COMING OFF WITHIN THE V.I.N. RANGE OF: 013360 Thru. 021883

Estimated Completion Time: .25 Hour

Parts: See Page # 4

REQUIRED TOOLS & SUPPLIES:

(1) Rubber Mallet

SPECIAL TOOLS:

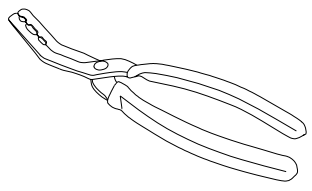
TOOL	
DESCRIPTION	WINDSHIELD WIPER ARM REMOVER
VENDOR P/N	3004 - JTC® Auto tools
APPLICATION	Removal of Windshield Wiper Arm

The following instructions are for replacing the windshield wiper arms on all models of GEM cars "ONLY WITH WIPER ARMS COMING LOOSE" within the specified V.I.N. range. To replace the windshield wiper arm, proceed as follows.

WARNING!

To prevent personal injury or property damage: Switch the 72-volt Master Disconnect to "OFF", be sure the ignition switch is always in the "OFF" position and that the "KEY" is removed. Set the parking brake before servicing, adjusting, or repairing.

WARNING!

HIGH VOLTAGE



You could be seriously or fatally injured by electric shock if you attempt to open, repair, test, inspect or adjust. Only qualified technicians should open and service. Consult service manual.

1. Remove bench seat cushion (rear bench seat cushion for 4 passenger vehicles) to access the Master Disconnect switch. Switch master disconnect off. (See Fig. # 1.

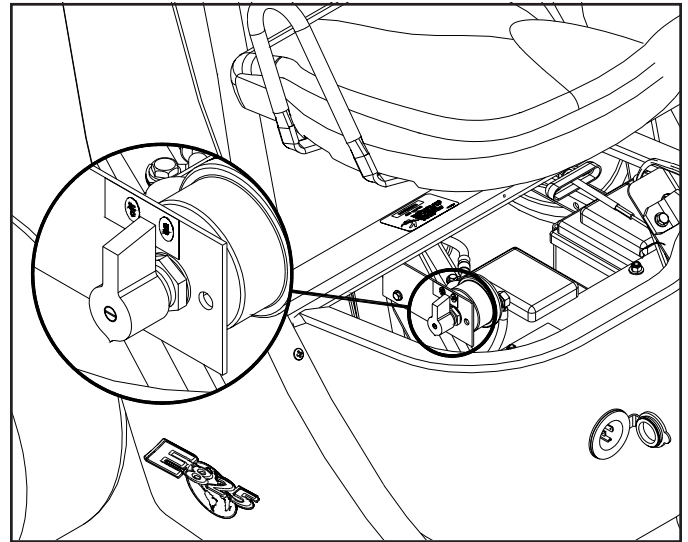

Fig. # 1 Switch master disconnect off

SERVICE PROCEDURE:

OPENING THE HOOD

1. Remove the Qty. two (2) 1" Dia. Hood Knobs securing the hood. (See Fig # 2).

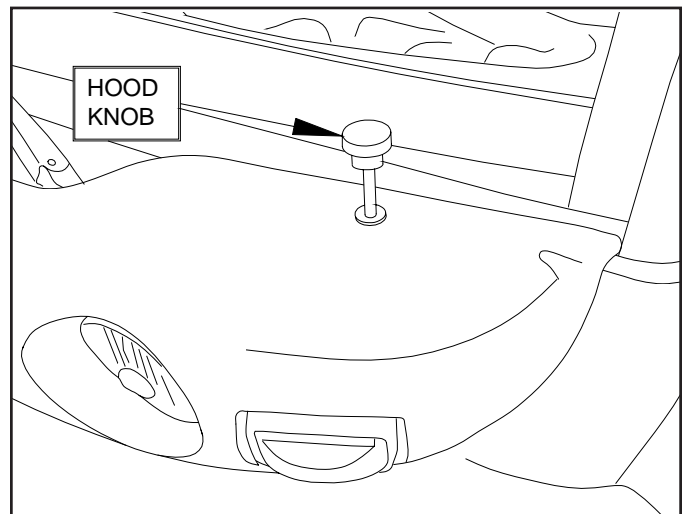

Fig. # 2 Loosen and remove hood knobs

2. Newer models only require for the latch to be unclasp. (See Fig # 3).

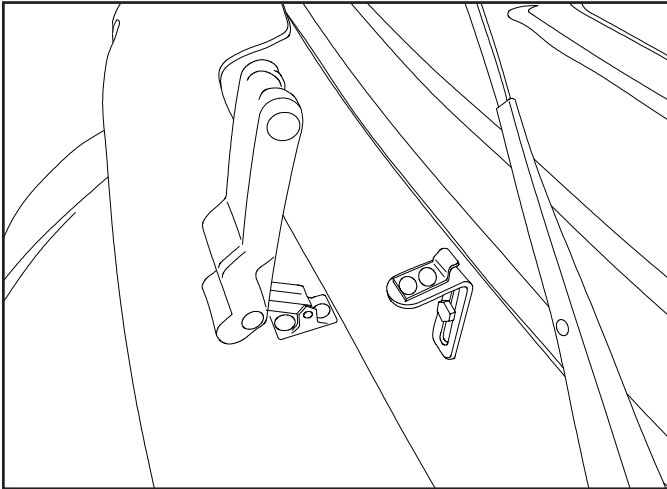

Fig. # 3 unclasp latch

2. Remove the wiper arm assembly from the windshield wiper motor shaft. (See Fig. # 5)

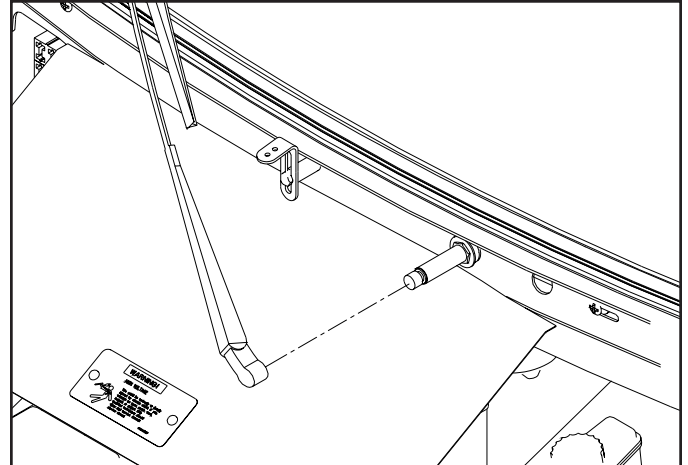

Fig. # 5 Remove wiper arm assembly

3. Open the hood.

REMOVING THE WIPER ARM:

1. Use the windshield wiper arm removal tool to remove the arm. Notice the direction to pry off the arm. (See Fig. # 4)

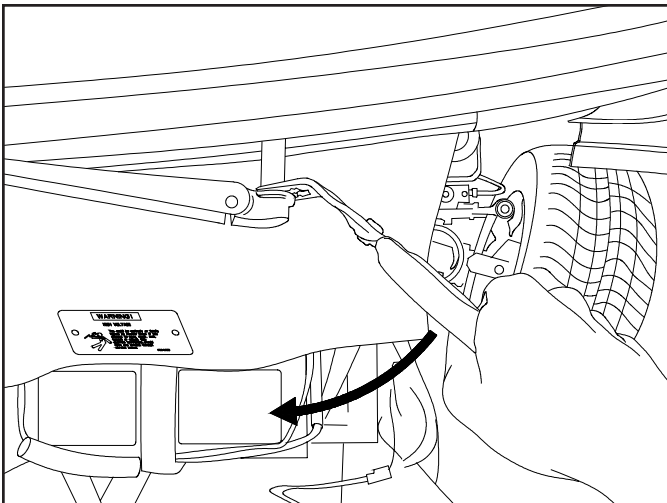

Fig. # 4 Pry in this direction to remove wiper arm

3. Inspect the splines on the arm. If the splines are a coarse 24 tooth spline, then the wiper arm needs to be replaced. (See Fig. # 6)

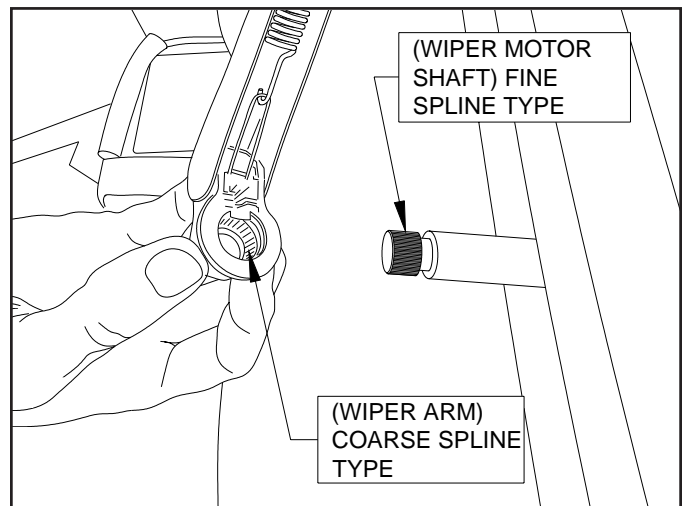

Fig. # 6 Note the mismatched splines

4. Press tab to release the wiper harp from the wiper arm. Discard the old wiper arm. (See Fig. # 7)

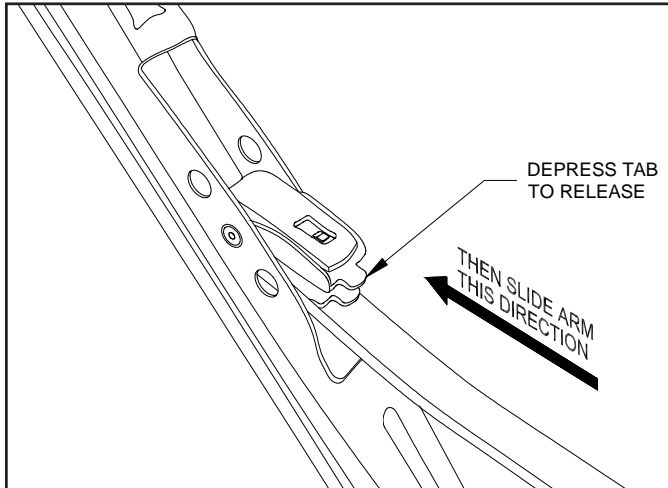

Fig. # 7 Remove wiper harp from arm

5. Install old wiper harp to new wiper arm by reversing step # 4. (See Fig. # 7)
6. Install new wiper assembly to wiper motor shaft at the same angle as previously mounted. Tap in place with a rubber mallet. Make sure tab seats properly. (See Fig. # 8)

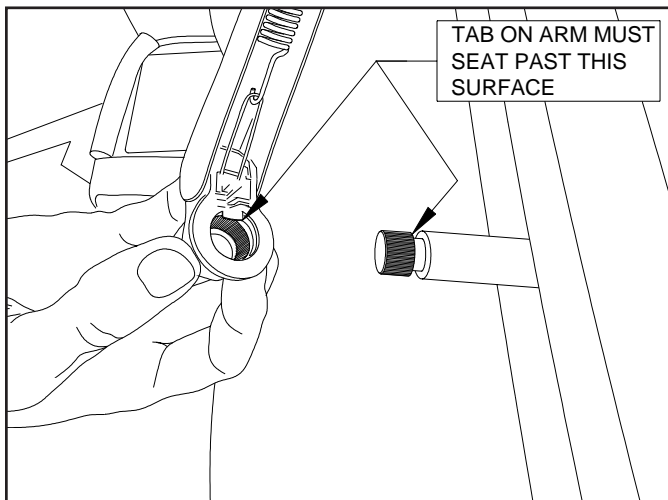
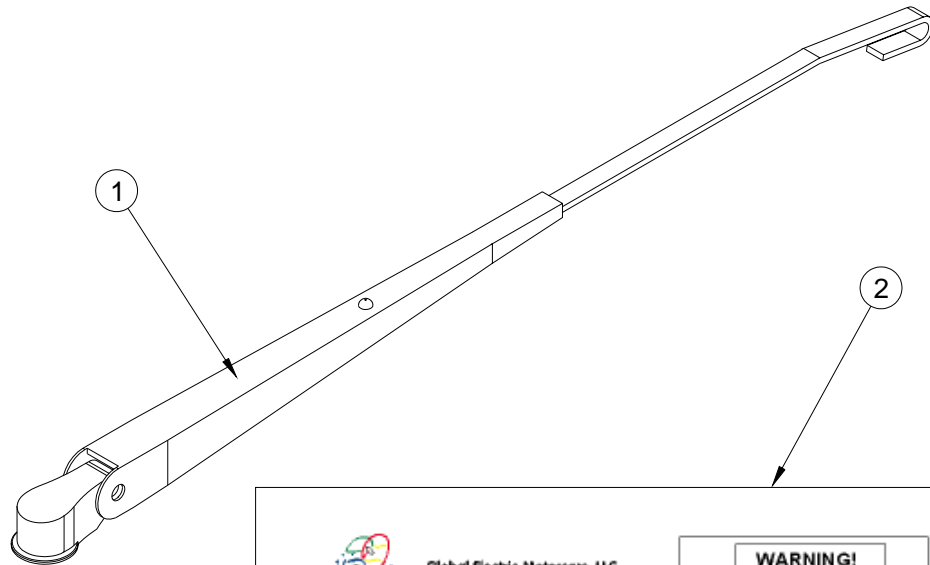



Fig. # 8 Install new wiper assembly to wiper motor shaft

7. Check wiper operation and adjust if necessary.
8. Close hood.
9. Turn master disconnect switch to the "ON" position.

PARTS





Global Electric Motorcars, LLC
A DaimlerChrysler Company

INSTRUCTIONS
Product: GEM Electric Motorcars
Models: All
Subject: Instructions for Removing and Installing New Wiper Arm For Vehicles With Wiper Arms coming loose
Effected V.I.N. Range:
ONLY VEHICLES WITH WIPER ARMS COMING OFF WITHIN THE V.I.N. RANGE OF:
 010360 Thru 021883
Estimated Completion Time: .25 Hour
Parts: See Page #4

REQUIRED TOOLS & SUPPLIES:
 (1) Rubber Mallet

SPECIAL TOOLS:

WARNING!

HIGH VOLTAGE

You could be seriously or fatally injured by electric shock if you attempt to open, repair, test, inspect or adjust. Only qualified technicians should open and service. Consult service manual.



1. Remove bench seat cushion (rear bench seat cushion for 4 passenger vehicles) to access the Master Disconnect switch. Switch master disconnect off (See Fig. #1).

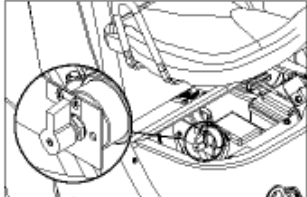

0111-00720 - ASSY, WIPER ARM REPLACEMENT SERVICE KIT

ITEM	PART NO.	DESCRIPTION	QTY.
1	0310-00980	ARM, WIPER	1
2	1010-00062	INSTRUCTION, WIPER ARM REPLACEMENT SERVICE KIT	1

COMPLETION REPORTING AND REIMBURSEMENT

Claims for vehicles which have been serviced must be filed in the warranty claims section of GEM Connect for reimbursement.

<u>LABOR DESCRIPTION</u>	<u>LABOR OPERATION NUMBER</u>	<u>TIME ALLOWANCE</u>
Remove wiper arm assembly from vehicle. Remove wiper blade assembly from old wiper arm assembly, assemble to new wiper arm. Install new complete wiper arm assembly to wiper motor.	BDY-01-210	.25 Hours

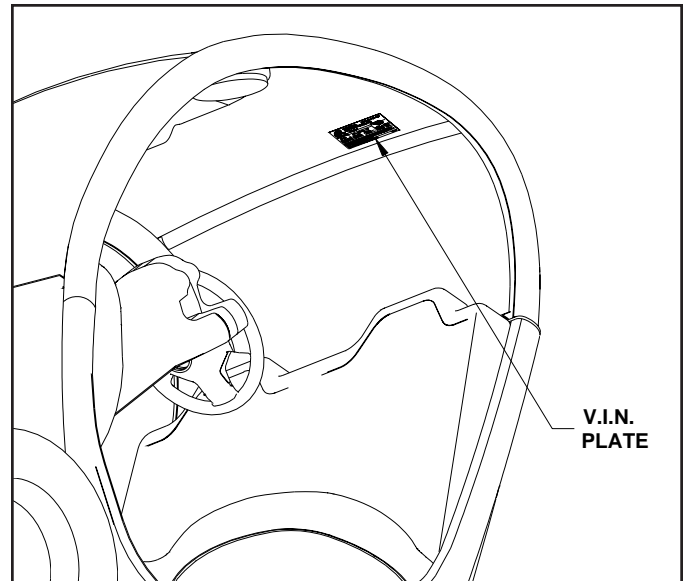

Fig. #9 V.I.N. plate location

ADDITIONAL INFORMATION

If you have any questions or need assistance in completing this action, please contact GEM Technical Support at 866.764.0616

Remember to record the last six digits of your Vehicle Identification Number (V.I.N.) in the space provided below before calling. Use (Fig. # 9 & 10) to locate the V.I.N. plate. Also the V.I.N. will be used when claiming warranty on GEM Connect.

V.I.N. _____

		MANUFACTURED BY: U.S. Patent No. Des. 419,107 Global Electric Motorcars, LLC.	
Web: www.gemcar.com		DATE OF MFG: 1/15/01	
GVWR: 953KG (2,100 LBS.)		COLD INFLATION PRESSURE	
GAWR	TIRE - DIMENSION - RIM		KPA/PSI
Front 468KG (1,023 LBS)	165/70R-12	T12x4J	207KPA (30PSI)
Rear 468KG (1,077 LBS)	165/70R-12	T12x4J	207KPA (30PSI)
THIS VEHICLE CONFORMS TO ALL APPLICABLE U.S. FEDERAL MOTOR SAFETY, BUMPER, AND THEFT PREVENTION STANDARDS (FMVSS) IN EFFECT ON THE DATE OF MANUFACTURE SHOWN A		SGL-DUAL SINGLE	
V.I.N. XXXXXXXXXXXXXXX XXXX		U.S. VIN	
TYPE OF VEHICLE: _____		LAST SIX NUMBERS OF V.I.N.	

Fig. #10 V.I.N. use last six numbers



Global Electric Motorcars, LLC

A DaimlerChrysler Company

Toll Free: 866.764.0616

Fax: 701.232.9528

e-mail: service@gemcar.com

Web Site: www.gemcar.com