



Global Electric Motorcars, LLC

A DaimlerChrysler Company

SERVICE MANUAL



FORWARD

The information contained in this service manual has been prepared for the professional automotive technician involved in daily repair operations. Information describing the operation and use of standard and optional equipment is included in the Owner's Manual provided with the vehicle.

Information in this manual is divided into groups. These groups contain description, operation, diagnosis, testing, adjustments, removal, installation, disassembly, and assembly procedures for the systems and components. To assist in locating a group title page, use the Group Tab Locator. The solid bar after the group title is aligned to a solid tab on the first page of each group. The first page of the group has a contents section that lists major topics within the group. If you are not sure which Group contains the information you need, look up the Component/System in the alphabetical index located in the rear of this manual.

A Service Manual Comment form is included at the rear of this manual. Use the form to provide with your comments and suggestions.

Tightening torques are provided as a specific value throughout this manual. This value represents the midpoint of the acceptable engineering torque range for a given fastener application. These torque values are intended for use in service assembly and installation procedures using the correct OEM fasteners. When replacing fasteners, always use the same type (part number) fastener as removed.

Global Electric Motorcars, L.L.C. reserves the right to change testing procedures, specifications, diagnosis, repair methods, or vehicle wiring at any time without prior notice or incurring obligation.

GROUP TAB LOCATOR

0 - INTRODUCTION

2 - SUSPENSION AND STEERING

3 - DRIVETRAIN

4 - BRAKES

5 - ELECTRICAL

6 - WHEELS & TIRES

7 - BODY

8 - WORD INDEX



Global Electric Motorcars, LLC

A DaimlerChrysler Company

CONTENTS

General Warnings	0-2
Vehicle Identification/Safety Certification Label	0-2
Fastener Usage	0-3
Parts and Lubricant Recommendation	0-4
Maintenance Schedules	0-4
Hoisting and Jacking	0-4

USING THIS MANUAL

Appropriate service methods and proper repair procedures are essential for the safe, reliable operation of your vehicles, as well as the safety of the individual doing the work. This service manual provides general directions for accomplishing service and repair work with recommended techniques. Following them will help assure reliability.

There are numerous variations in procedures, techniques, tools, and parts for servicing your vehicle, as well as in the skill levels of the individuals doing the work. This manual cannot possibly anticipate all such variations and provide advice or cautions for each. Accordingly, anyone who departs from the instructions provided in this manual must first establish that he/she compromises neither their personal safety nor vehicle integrity by their choice of methods, tools, or parts.

GENERAL WARNINGS

The following should be followed whenever you are working on your vehicle:

- Always wear safety glasses for eye protection.
- Use safety stands whenever a procedure requires you to be under the vehicle.
- Be sure that the Ignition Switch is always in the "OFF" position and that the "KEY" is removed.
- Be sure to switch the 72-volt Master Disconnect to "OFF".
- Set the Parking Brake and place wood blocks (4" x 4" or larger) to the front and rear surfaces of the tires to restrain the vehicle from movement.
- Do not smoke while working on your vehicle. Batteries produce hydrogen gas that is extremely flammable and will explode upon exposure to any ignition source.
- Remove rings, watches, loose jewelry, and loose clothing when working on your vehicle to avoid injury.

NOTE: The terms right-hand (RH) and left-hand (LH) are relative to one sitting in the driver's seat. Therefore, right-hand refers to the passenger side, and left-hand refers to the driver's side of the vehicle.

VEHICLE IDENTIFICATION/SAFETY CERTIFICATION LABEL

Description

A label, containing the Vehicle Identification Number (VIN) and safety certification, is located above the bench seat on the underside of the rear roof panel on the driver's side.

The information on the label includes:

- Vehicle Identification Number
- Month and year of manufacture
- Gross Vehicle Weight Rating
- Gross Front and Rear Axle Ratings
- Wheel size
- Tire size
- Cold tire pressure

		MANUFACTURED BY:		U.S. Patent No. Des. 419,107	
		Global Electric Motor Cars, L.L.C.		DATE OF MFG: 10/3/01	
GVWR: 953KG (2,100 LBS)		Web: www.gemcar.com		COLD INFLATION PRESSURE	
GAWR		TIRE - DIMENSION - RIM		KPA/PSI SGL/DUAL	
Front: 485KG (1,071 LBS)		165 / 70R - 12 T12 x 4J		207KPA (30PSI) Single	
Rear: 455KG (1,002 LBS)		165 / 70R - 12 T12 x 4J		207KPA (30PSI) Single	
THIS VEHICLE CONFORMS TO ALL APPLICABLE U.S. FEDERAL MOTOR VEHICLE SAFETY BUMPER AND THEFT PREVENTION STANDARDS (FMVSS) IN EFFECT ON THE DATE OF MANUFACTURE SHOWN ABOVE.					
VIN: XYX000000000000000					
TYPE OF VEHICLE: Low Speed Vehicle (LSV) U.S. VIK:					

Figure 1 - VIN/Certification Label

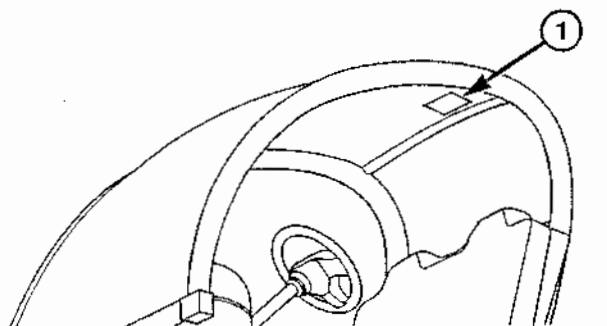

Figure 2 - VIN/Certification Location

1. VIN/Certification Label Location (Typical - 2-passenger model shown)

NOTE: The last six digits of the VIN are also stamped into the rear support for the bench seat cushion.

FASTENER USAGE**Description****WARNING!**

Use of an incorrect fastener may result in component damage or personal injury.

Fasteners and torque specifications references in this Service Manual are identified SAE format.

During any maintenance or repair procedure, it is important to salvage all fasteners (nuts, bolts, etc.) for re-assembly. If the fastener is not salvageable, a fastener of equivalent specification must be used.

NOTE: Nylon lock nuts must always be replaced.

TORQUE SPECIFICATIONS

DESCRIPTION	THREAD SIZE	Use Loctite® 242	INCH-POUNDS	FOOT-POUNDS
Battery Cables to Battery Post		NO	70	---
Brake line to Wheel/Master Cylinder		NO	---	37
Brake Master Cylinder to Frame	5/16 - 18	NO	225	---
Brake Pedal Assembly to Frame	5/16 - 18	NO	225	---
Brake Pedal to Push Rod	3/8 - 16	NO	---	30
Brake, Drum Assembly to Steering Knuckle	M8 x 1.25	NO	225	---
Brake, Parking - Cable Mount to Rear Suspension	1/2" x 13	NO	---	90
Control Arm to Frt. Suspension Frame	M12 x 1.75	NO	---	60
Differential to Frt. Suspension Frame	5/16" -- 18	NO	225	---
Front Suspension Frame to Frame (Lower)	M12 x 1.75	YES	---	60
Front Suspension Frame to Frame (Upper)	3/8 - 16	YES	---	30
Half Shaft to Drum Brake Assembly	M16 x 1.5	YES	---	74
King Pin Pinch Bolt	M6 - 1	YES	65	---
Motor to Differential	1/4 - 20	YES	65	---
Rack & Pinion to Frt. Suspension Frame	M8 x 1.25	NO	225	---
Rear Suspension Frame to Frame	M12 x 1.75	NO	---	60
Seat Belt D-Ring to Frame		NO	---	60
Seat Belt End to Frame		NO	---	60
Seat Belt Latch Assembly to Frame		NO	---	60
Seat Belt Latch Assembly to Bracket - Bucket Seat		NO	---	60
Seat Belt Retractor to Bracket - Bucket Seat		NO	---	60
Seat Belt Retractor to Frame - Bench Seat		NO	---	60
Shock Absorber Lower Bolt	M12 x 1.75	NO	---	60
Shock Absorber Upper Bolt	M12 x 1.75	NO	---	60
Steering Column Pinch Bolt	3/8 - 16	NO	---	30
Steering Column to Dash Frame	5/16 - 18	NO	225	---
Steering Wheel to Steering Shaft		NO	225	
Tie Rod Stud Nut	M10 x 1.5	NO	---	35
Wheel Lug Nuts	M10 x 1.5	NO	---	50
Yoke to Control Arm	M12 x 1.75	NO	---	60

PARTS AND LUBRICANT RECOMMENDATION

When service is required, GEM recommends that only GEM replacement parts be used. GEM provides the best engineered products for servicing GEM vehicles.

Description - Lubricants and Grease

Only lubricants bearing designations defined by The Society for Automotive Engineers (SAE) should be used to service a GEM vehicle.

The National Lubricating Grease Institute (NLGI) rates lubricating grease for quality and usage. All approved products have the NLGI symbol (Fig. 3) on the label. At the bottom of the symbol is the usage and quality identification letters. The letter "G" identifies wheel-bearing lubricant. The letter "L" identifies chassis lubricant. The letter following the usage letter indicates the quality of the lubricant. The following symbols indicate the highest quality.

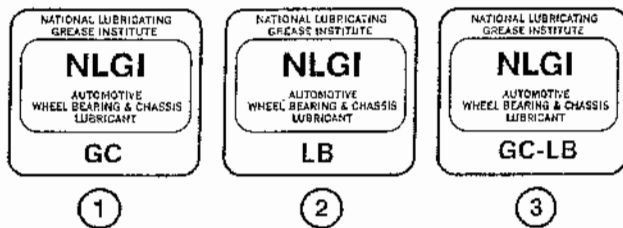

Figure 3 - NLGI Symbols

1. Wheel Bearing Lubrication
2. Chassis Lubrication
3. Chassis and Wheel Bearing Lubrication

Description - Differential

Use SAE 30 weight motor oil.

Description - King Pin Lubricant

Use only grease with NLGI "L" or "LB" symbol.

Description - Brake Fluid

Use only DOT3 brake fluid from an unopened container when filling the master cylinder to prevent contaminants from entering the brake system.

MAINTENANCE SCHEDULES

Perform the following inspections, and corrections as necessary, on a monthly basis.

Item	Description
1.	Check all six batteries for proper water levels.
2.	Check battery terminals for tight connections.
3.	Check battery terminals for corrosion.
4.	Check tires for correct PSI and wear.
5.	Check zero fittings on each kingpin and grease if needed.
6.	Check for proper operation of hand brake.
7.	Check Master cylinder for proper brake fluid levels.
8.	Check brake lines for leaks.
9.	Check seat belts for proper operation.
10.	Check headlights, horn, turn signals, windshield wiper and brake lights for proper operation.

HOISTING AND JACKING

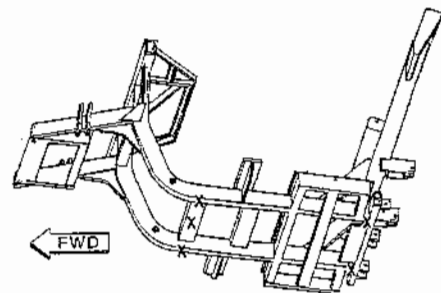

Figure 4 - Hoisting/Jacking Locations

A vehicle can be lifted with:

- A single-post frame-contact hoist
- A twin-post, chassis hoist
- A ramp-type drive-on hoist.

NOTE: When a frame-contact type hoist is used, verify that the lifting pads are positioned properly.

WARNING!

The hoisting and jack lifting points provided are for a complete vehicle. When a chassis or drivetrain component is removed from a vehicle, the center of gravity is altered making some hoisting conditions unstable. Properly support or secure vehicle to hoisting device when these conditions exist.

CAUTION!

Do not attempt to lift a vehicle with a floor jack positioned under:

- An axle tube
- Body side panel or sill
- Front control arm

When properly positioned, a floor jack can be used to lift a GEM vehicle. Support the vehicle in the raised position with jack stands at the locations indicated.

CONTENTS

Wheel Alignment	2-2
Alignment	2-4
Front Suspension	2-5
Spring Over Shock Absorber Assembly	2-6
Control Arm Assembly (with bushings)	2-7
Rear Suspension	2-8
Rear Suspension Frame/Axle	2-8
Steering Wheel	2-11
Steering Column Assembly	2-13
Steering Gear	2-14
Outer Tie Rod End	2-15
King Pin Assembly	2-16
Steering Knuckle	2-17
Yoke	2-18
Special Tools	2-18

SUSPENSION AND STEERING

WHEEL ALIGNMENT

Description

Front wheel alignment is essential for proper vehicle handling and passenger safety. Front-end damage or replacement of any steering or front suspension component will require inspection of the alignment to determine if it is still within specifications.

CAUTION!





Never attempt to modify suspension or steering components by heating or bending.

Inspection - Pre-Alignment

The steering system should be inspected for wear. Any worn or damaged components must be replaced before checking alignment. The pressure of all four tires should be set to specification with a high quality tire pressure gauge, not the pencil type, before checking the alignment or performing a driving inspection. Customer complaints of poor handling or excessive front tire wear should be confirmed by a test drive. The test drive should be performed on a smooth level surface with plenty of room to maneuver.

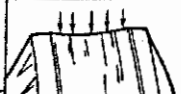
Before starting wheel alignment, the following inspection and necessary corrections must be completed. Refer to Suspension and Steering System Diagnosis Chart below for additional information.

1. Inspect tires for size, air pressure and tread wear.
2. Inspect front wheel bearings for wear.
3. Inspect kingpins, linkage pivot points and steering gear for looseness, roughness or binding.
4. Inspect suspension components for wear and noise.
5. Road test the vehicle.

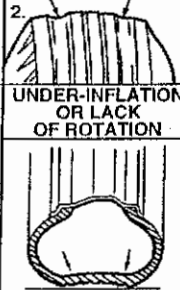
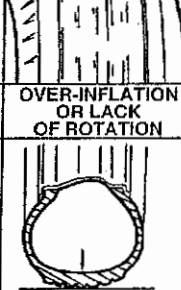
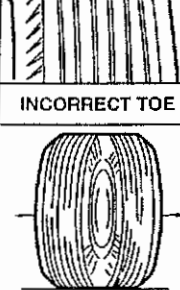
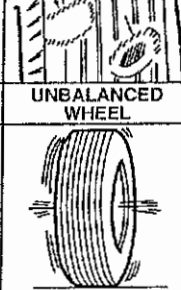
CONDITION	RAPID WEAR AT SHOULDERS	RAPID WEAR AT CENTER	CRACKED TREADS	FEATHERED EDGE	BALD SPOTS	SCALLOPED WEAR
EFFECT						
CAUSE	UNDER-INFLATION OR LACK OF ROTATION 	OVER-INFLATION OR LACK OF ROTATION 	UNDER-INFLATION	INCORRECT TOE 	UNBALANCED WHEEL OR TIRE DEFECT* 	LACK OF ROTATION OF TIRES OR WORN OR OUT-OF-ALIGNMENT SUSPENSION.
CORRECTION	ADJUST PRESSURE TO SPECIFICATIONS WHEN TIRES ARE COOL ROTATE TIRES			ADJUST TOE-IN TO SPECIFICATIONS	DYNAMIC OR STATIC BALANCE WHEELS	ROTATE TIRES AND INSPECT SUSPENSION SEE GROUP 2

* HAVE TIRE INSPECTED FOR FURTHER USE.

Figure 1 - Tire Wear Chart

Diagnosis and Testing

CONDITION	POSSIBLE CAUSES	CORRECTION
FRONT END NOISE	<ol style="list-style-type: none"> 1. Loose or worn wheel bearing. 2. Loose or worn steering or suspension components 	<ol style="list-style-type: none"> 1. Replace drum brake assembly. 2. Tighten or replace components as necessary.
EXCESSIVE PLAY IN STEERING	<ol style="list-style-type: none"> 1. Loose or worn wheel bearing. 2. Loose or worn steering or suspension components. 3. Loose or worn steering gear. 	<ol style="list-style-type: none"> 1. Replace drum brake assembly. 2. Tighten or replace components as necessary. 3. Tighten or replace steering gear.
FRONT WHEELS SHIMMY	<ol style="list-style-type: none"> 1. Loose or worn wheel bearing. 2. Loose or worn steering or suspension components. 3. Tires worn or out of balance. 	<ol style="list-style-type: none"> 1. Replace drum brake assembly. 2. Tighten or replace components as necessary. 3. Replace or balance tires.
VEHICLE INSTABILITY	<ol style="list-style-type: none"> 1. Loose or worn wheel bearing. 2. Loose or worn steering or suspension components. 3. Tire pressure. 4. Alignment 	<ol style="list-style-type: none"> 1. Replace drum brake assembly. 2. Tighten or replace components as necessary. 3. Adjust tire pressure. 4. Align vehicle to specifications.
EXCESSIVE STEERING EFFORT	<ol style="list-style-type: none"> 1. Loose or worn steering gear. 2. Steering column u-joints binding. 3. Tire pressure. 4. Alignment. 	<ol style="list-style-type: none"> 1. Replace steering gear. 2. Replace steering column. 3. Adjust tire pressure. 4. Align vehicle to specifications.
VEHICLE PULLS TO ONE SIDE	<ol style="list-style-type: none"> 1. Tire pressure 2. Tire 3. Worn wheel bearings. 4. Loose or worn kingpins. 5. Weak or broken spring/shock absorber assembly. 	<ol style="list-style-type: none"> 1. Adjust tire pressure 2. Criss-cross front tires. 3. Replace drum brake assembly. 4. Tighten or replace kingpins as necessary. 5. Replace spring/shock/absorber.
VEHICLE PULLS TO ONE SIDE WHILE BRAKING	<ol style="list-style-type: none"> 1. Brakes worn or out of adjustment. 2. Air in brake lines 3. Loose or worn steering or suspension components. 4. Worn wheel bearings. 	<ol style="list-style-type: none"> 1. Adjust or replace brake components. 2. Bleed brakes. 3. Tighten or replace components as necessary. 4. Replace drum brake assembly.
EXCESSIVE TIRE WEAR AT CENTER OF TIRE	<ol style="list-style-type: none"> 1. Toe out of specification. 2. Tires over-inflated. 	<ol style="list-style-type: none"> 1. Reset toe to proper specification 2. Adjust tire pressure to proper specification
VEHICLE CANNOT REACH TOP SPEED	<ol style="list-style-type: none"> 1. Toe out of specification 2. Park brake on or cables tensioned too tight. 3. Brakes binding 	<ol style="list-style-type: none"> 1. Reset toe to proper specification 2. Release park brake or adjust park brake cable tension 3. Repair or replace brakes.
VEHICLE WILL NOT COAST	<ol style="list-style-type: none"> 1. Toe out of specification 2. Park brake on or cables tensioned too tight. 3. Brakes binding 	<ol style="list-style-type: none"> 1. Reset toe to proper specification 2. Release park brake or adjust park brake cable tension 3. Repair or replace brakes.
VEHICLE MAKES THUMPING SOUND ON TIGHT TURNS	<ol style="list-style-type: none"> 1. Toe out of specification 2. CV boot cut or torn 	<ol style="list-style-type: none"> 1. Reset toe to proper specification 2. Replace CV boot.

ALIGNMENT

Description

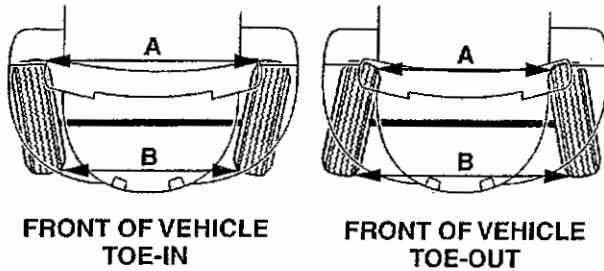

0033

TOP VIEW
Figure 2 - Toe-In vs. Toe-Out

Toe is the only available adjustment in the front wheel alignment. Toe is the difference between the leading inside edges and trailing inside edges of the front tires. It should be measured at a point above the ground equal to one-half the overall diameter of the wheel/tire assembly. The specification is + 1/16 inch toe in.

Wheel toe position out of specification causes unstable steering, uneven tire wear and steering wheel off-center.

Measuring Toe

1. Park the vehicle on a level flat surface.
2. Center the front wheels.
3. Measure distance from the inboard edge of the tread at the rear of the right front tire to the inboard edge of the tread at the rear of the left front tire.
4. Measure distance from the inboard edge of the tread at the front of the right front tire to the inboard edge of the tread at the front of the left front tire.
5. Subtract the front measurement from the rear measurement. If the front measurement is less than the rear, the vehicle has toe-in, and is shown with a plus sign (+1/16"). If the front measurement is greater than the rear, the vehicle has toe-out, and the difference is shown with a minus sign (-1/16").

Adjusting Toe

1. Center the front wheels.
2. Inspect the position of the pinch bolt that joins the steering column shaft to the steering gear. This bolt must be horizontal and under the shaft (see Figure 3). If necessary, turn the steering wheel to put the bolt in this orientation. Remove and re-center the steering wheel if required.
3. Lash the steering wheel in the centered position.
4. Loosen the lock nuts on the tie rods.
5. Use locking pliers to hold the clamp that secures the small end of the boot to the tie rod. Take care not to damage the boot.
6. Using a 5/8" wrench, rotate the tie rods so that the front wheels have the specified toe-in (see Figure 4).
7. Tighten the lock nuts.

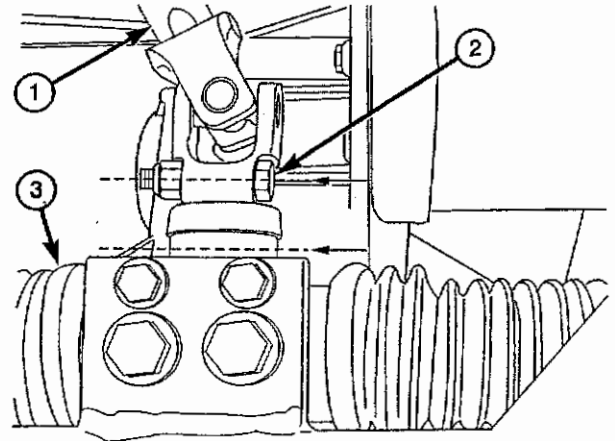

0081

Figure 3 - Pinch Bolt Orientation

1. Steering shaft
2. Pinch bolt (parallel to steering gear mounting bracket)
3. Steering gear

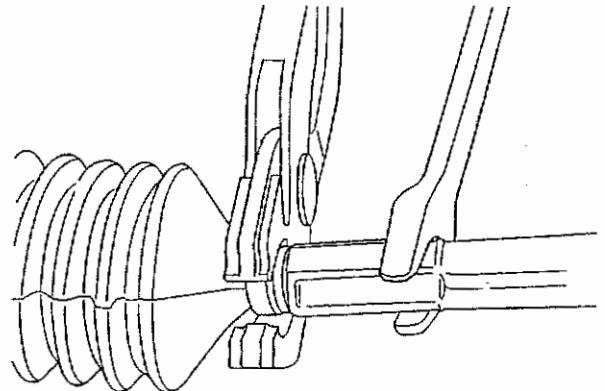

0034

Figure 4 - Tie Rod Adjustment

FRONT SUSPENSION

Description

The front suspension is designed to allow each wheel to adapt to different road surfaces independently. The wheels are mounted to drum brake assemblies, which in turn are mounted to the steering components attached to a control arm, which pivots up and down on bushings. Spring and shock absorber assemblies at each yoke provide cushioning.

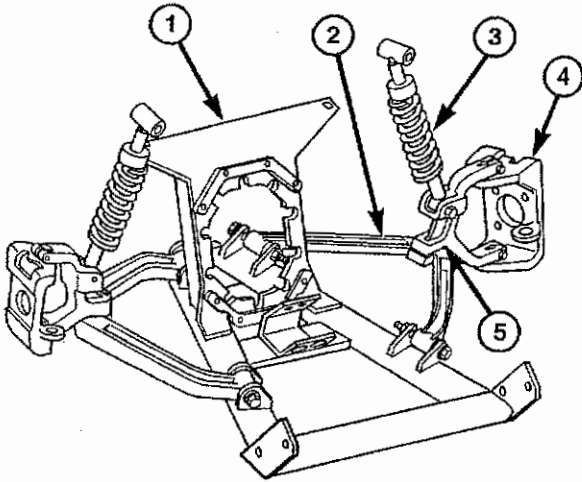

0074

Figure 5 - Front Suspension System

- 1. Front suspension frame
- 2. Control arm
- 3. Spring/shock absorber
- 4. Knuckle
- 5. Yoke

CAUTION!

Suspension components with rubber/urethane bushings should be tightened with the vehicle at normal ride height. It is important to have the springs supporting the weight of the vehicle when the fasteners are tightened. This will maintain vehicle ride comfort and prevent premature bushing wear.

TORQUE SPECIFICATIONS

DESCRIPTION	THREAD SIZE	Use Loctite® 242	INCH-POUNDS	FOOT-POUNDS
Brake line to Wheel/Master Cylinder		NO	---	37
Brake, Drum Assembly to Steering Knuckle	M8 x 1.25	NO	225	---
Control Arm to Frt. Suspension Frame	M12 x 1.75	NO	---	60
Differential to Frt. Suspension Frame	5/16" -- 18	NO	225	---
Front Suspension Frame to Frame (Lower)	M12 x 1.75	YES	---	60
Front Suspension Frame to Frame (Upper)	3/8 - 16	YES	---	30
Half Shaft to Drum Brake Assembly	M16 x 1.5	YES	---	74
King Pin Pinch Bolt	M6 - 1	YES	65	---
Rack & Pinion to Frt. Suspension Frame	M8 x 1.25	NO	225	---
Rear Suspension Frame to Frame	M12 x 1.75	NO	---	60
Shock Absorber Lower Bolt	M12 x 1.75	NO	---	60
Shock Absorber Upper Bolt	M12 x 1.75	NO	---	60
Steering Column Pinch Bolt	3/8 - 16	NO	---	30
Steering Column to Dash Frame	5/16 - 18	NO	225	---
Steering Wheel to Steering Shaft		NO	225	
Tie Rod Stud Nut	M10 x 1.5	NO	---	35
Wheel Lug Nuts	M10 x 1.5	NO	---	50
Yoke to Control Arm	M12 x 1.75	NO	---	60

SPRING OVER SHOCK ABSORBER ASSEMBLY

Description

The Gem 825 vehicles combine a spring and shock absorber into a single unit. They are used on both the front and rear suspension. They are not serviceable, but must be replaced.

Operation

The shock absorbers dampen jounce and rebound of the vehicle over various road and terrain conditions

Diagnosis and Testing

Movement between mounting bushings and metal brackets or attaching components may cause a knocking or rattling noise from a shock absorber/spring unit. Tightening the attaching nuts can usually stop these noises. If the noise persists, inspect for damaged and worn bushings and/or attaching components. Replace if any of these conditions exist.

A squeaking noise from the shock absorber may be caused by the hydraulic valving and may be intermittent. This condition is not repairable and the shock absorber must be replaced.

The shock absorbers are not refillable or adjustable. If a malfunction or leak occurs, the shock absorber/spring unit must be replaced.

To test a shock absorber, hold it in an upright position and force the piston in and out of the cylinder four or five times. The action throughout each stroke should be smooth and even.

CAUTION!

The shock absorber bushings do not require any type of lubrication. Do not attempt to stop bushing noise by lubricating them. Grease and mineral oil-based lubricants will deteriorate the bushing.

Removal

1. Raise vehicle off floor and support safely with jack stands.
2. Using a 3/4-inch wrench and socket, remove mounting bolts and nuts.
3. Work shock out of mounts.

Cleaning and Inspection

Check bolts and nuts for signs of wear and replace if necessary.

Installation

1. Work shock into upper and lower mounts.
2. Attach with mounting bolts.
3. Lower vehicle to the ground.
4. Torque mounting bolts to 60 foot-pounds.

TORQUE SPECIFICATIONS

DESCRIPTION	THREAD SIZE	Use Loctite® 242	INCH-POUNDS	FOOT-POUNDS
Shock Absorber Lower Bolt	M12 x 1.75	NO	---	60
Brake, Drum Assembly to Steering Knuckle	M12 x 1.75	NO	---	60

CONTROL ARM ASSEMBLY (WITH BUSHINGS)

Description

The control arm is a single casting that connects the front suspension to the front frame support assembly. It is connected to the front frame support by bolts passing through bushings that allow the control arm to pivot vertically.

NOTE: The bushings are not serviceable. The control arm and bushings must be replaced as a unit.

Removal

1. Remove hub cap.
2. Loosen wheel lug nuts,
3. Loosen half-shaft retaining nut.
4. Raise vehicle off floor and safely support.
5. Remove lug nuts and wheel
6. Remove half shaft nut.
7. Disconnect brake line, taking care to capture brake fluid in a suitable container for disposal.
8. Disconnect tie rod end from steering knuckle. (See TIE ROD END in this section.)
9. Disconnect spring/shock absorber lower mounting bolt.
10. Provide support for control arm assembly, then remove bolts connecting arm to front frame support.
11. Remove control arm assembly.
12. Remove yoke and knuckle assembly.

Installation

1. Attach yoke and knuckle assembly to control arm. Tighten to 60 foot-pounds.
2. Attach control arm assembly to front suspension frame. Tighten to 60 foot-pounds.
3. Attach spring/shock absorber lower mounting bolt. Tighten just snug.
4. Attach tie rod end to steering knuckle. Tighten to 35 foot-pounds.
5. Re-connect the brake line. Tighten to 37 foot-pounds.
6. Bleed the brakes. (See BRAKE BLEEDING in BRAKES section.)
7. Replace wheel, tighten lug nuts just snug.
8. Replace half shaft washer and bolt, tighten just snug.
9. Lower vehicle to ground, then tighten lug nuts to 50 foot-pounds..
10. Back off half shaft nut slightly, add Loctite(242 and tighten to 74 foot-pounds.
11. Tighten control arm to front suspension frame mounting bolts to 60 foot-pounds.
12. Tighten spring/shock absorber lower mounting bolt to 60 foot-pounds.
13. Replace hub-cap.

TORQUE SPECIFICATIONS

DESCRIPTION	THREAD SIZE	Use Loctite® 242	INCH-POUNDS	FOOT-POUNDS
Brake line to Wheel/Master Cylinder		NO	---	37
Brake line to Wheel/Master Cylinder		NO	---	37
Brake, Drum Assembly to Steering Knuckle	M8 x 1.25	NO	225	---
Control Arm to Frt. Suspension Frame	M12 x 1.75	NO	---	60
Half Shaft to Drum Brake Assembly	M16 x 1.5	YES	---	74
Shock Absorber Lower Bolt	M12 x 1.75	NO	---	60
Shock Absorber Upper Bolt	M12 x 1.75	NO	---	60
Tie Rod Stud Nut	M10 x 1.5	NO	---	35
Wheel Lug Nuts	M10 x 1.5	NO	---	50
Yoke to Control Arm	M12 x 1.75	NO	---	60

REAR SUSPENSION

Description

The rear suspension is comprised of a frame that includes the rear axle, and spring/shock absorbers.

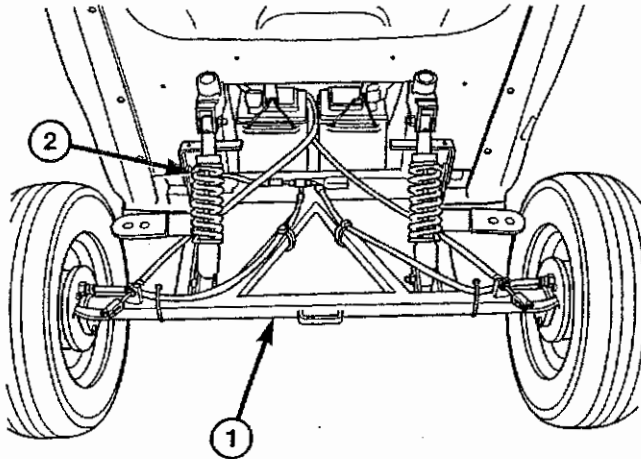

0041

Figure 5 - Rear Suspension System

1. Rear suspension frame/axle
2. Spring/Shock Absorber

Operation

The rear suspension frame pivots up and down on bolts where it is mounted to the rear of the frame. Rear drum brakes and wheels are mounted on flanges at each end of the rear axle. Spring/shock absorber units control the movement, thereby maintaining contact of the tires on the road.

CAUTION

Suspension components with rubber/urethane bushings should be tightened with the vehicle at normal ride height. It is important to have the springs supporting the weight of the vehicle when the fasteners are torqued. This will maintain vehicle ride comfort and prevent premature bushing wear.

REAR SUSPENSION FRAME/AXLE

Description

The rear suspension frame is attached to the rear of the vehicle frame by bolts in bushings.

Operation

The rear suspension frame provides a platform for the rear shocks, and acts as an axle for the rear wheels and brakes.

Removal

1. Remove wheel cover and loosen wheel lug nuts
2. Raise vehicle off floor and **support safely with jack stands with jack stands.**
3. Remove lug nuts and wheel.
4. Disconnect park brake cables. (See PARK BRAKE CABLES in BRAKES section.)
5. Disconnect rear brake lines, making sure to collect brake fluid in proper container for disposal.
6. Remove rear drum brake assemblies. (See REAR BRAKES in BRAKES section.)
7. Remove rear shock cover. (See REAR SHOCK COVER in BODY section.)
8. Remove spat to expose mounting locations. (See SPAT in BODY section.)
9. Make sure to properly support rear frame/axle assembly.
10. Remove spring/shock assemblies with 3/4-inch wrench and socket.
11. Remove bolts attaching frame/axle assembly to rear of frame.
12. Remove frame/axle assembly.

Cleaning and Inspection

Inspect frame/axle assembly for damage and/or worn bushings. Bushings are not serviceable. Replace the frame/axle assembly if worn or damaged.

Installation

1. Move frame/axle assembly into position on rear of vehicle frame.
2. Install bolts attaching frame/axle assembly to rear of frame. Tighten just snug.
3. Replace spring/shock assembly mounting bolts with 3/4-inch wrench and socket. Tighten just snug.
4. Replace spat. (See SPAT in BODY section.)
5. Replace rear shock cover. (See REAR SHOCK COVER in BODY section.)

6. Re-connect license plate wires, if so equipped.
(See LICENSE PLATE BRACKET in BODY section.)
7. Attach rear drum brake assemblies.
8. Re-connect rear brake lines.
(See REAR BRAKE in BRAKES section.)
9. Bleed brakes.
(See BLEEDING BRAKES in BRAKES section.)
10. Re-connect park brake cables.
(See PARK BRAKE CABLES in BRAKES section.)
11. Install wheel and lug nuts. Tighten lug nuts just snug.
12. Lower vehicle to floor.
13. Tighten rear suspension frame to frame bolts to 60 foot-pounds
14. Tighten spring/shock absorber mounting bolts to 60 foot-pounds.
15. Tighten wheel lug nuts to 50 foot-pounds.
16. Test park brake, and adjust cable tension.

TORQUE SPECIFICATIONS

DESCRIPTION	THREAD SIZE	Use Loctite® 242	INCH-POUNDS	FOOT-POUNDS
Brake line to Wheel/Master Cylinder		NO	---	37
Brake, Drum Assembly to Rear Axle	M8 x 1.25	NO	225	---
Brake, Drum Assembly to Steering Knuckle	M8 x 1.25	NO	225	---
Brake, Parking - Cable Mount to Rear Suspension	1/2" x 13	NO	---	90
Rear Suspension Frame to Frame	M12 x 1.75	NO	---	60
Shock Absorber Lower Bolt	M12 x 1.75	NO	---	60
Shock Absorber Upper Bolt	M12 x 1.75	NO	---	60
Wheel Lug Nuts	M10 x 1.5	NO	---	50

STEERING

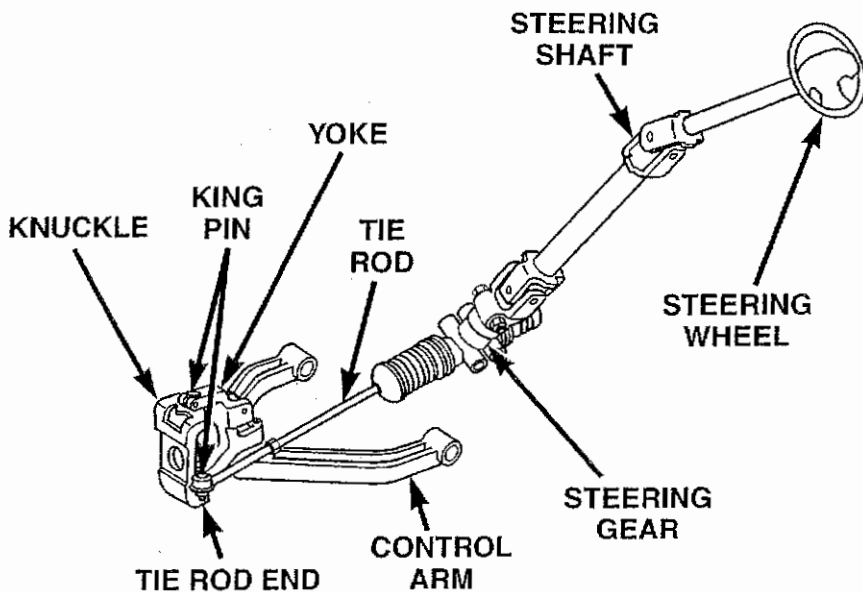

0036

Figure 6 - Steering System

Description

The steering system is comprised of:

- * Steering wheel
- * Steering column
- * Rack and pinion steering gear with integral tie rods
- * Tie rod ends
- * Steering Knuckle
- * Kingpins
- * Yoke

Operation

The steering column transmits rotation of the steering wheel to the pinion in the steering gear. The rotation of the pinion moves the gear rack in the steering gear from side to side. This lateral action of the rack pushes and pulls the tie rods that are attached to the steering knuckles. The steering knuckles pivot on kingpins that are mounted in yokes on the control arms. The wheel and brake assemblies are mounted to the steering knuckles. Pivoting action of the knuckles change the direction of the front wheels.

Diagnosis and Testing

CONDITION	POSSIBLE CAUSES	CORRECTION
RATTLE OR CLUNK	<ol style="list-style-type: none"> 1. Gear mounting bolts loose. 2. Loose or damaged suspension components 3. Loose or damaged steering column. 	<ol style="list-style-type: none"> 1. Tighten bolts to specification. 2. Inspect and repair suspension components. 3. Replace steering column.
DIFFICULT TO TURN WHEEL (WHEEL STICKS OR BINDS)	<ol style="list-style-type: none"> 1. Low tire pressure. 2. Worn or damaged steering components (kingpins, tie rod ends). 3. Steering column u-joints binding. 4. Steering gear worn. 	<ol style="list-style-type: none"> 1. Adjust tire pressure. 2. Inspect and repair/replace as necessary. 3. Replace steering column. 4. Replace steering gear.
STEERING WHEEL DOES NOT WANT TO RETURN TO CENTER POSITION	<ol style="list-style-type: none"> 1. Incorrect tire pressure. 2. Lack of lubrication suspension components. 	<ol style="list-style-type: none"> 1. Adjust tire pressure. 2. Inspect and lubricate suspension components. 3. Replace steering gear.
EXCESSIVE PLAY IN STEERING WHEEL	<ol style="list-style-type: none"> 1. Worn or loose suspension or steering components. 2. Worn or loose wheel bearings. 3. Steering gear mounting bolts loose. 4. Steering gear worn. 5. Steering column u-joints worn. 	<ol style="list-style-type: none"> 1. Inspect and repair as necessary. 2. Replace drum brake assembly. 3. Tighten mounting bolts. 4. Replace steering gear. 5. Replace steering column.
VEHICLE PULLS OR LEADS TO ONE SIDE	<ol style="list-style-type: none"> 1. Incorrect tire pressure. 2. Radial tire lead. 3. Brakes dragging. 	<ol style="list-style-type: none"> 1. Adjust tire pressure. 2. Rotate tires. 3. Adjust or repair as necessary.

STEERING WHEEL

Description

The steering wheel assembly consists of two parts, the steering wheel and the steering wheel cover.

Operation

Splines on the steering wheel mounting hole match to splines on the steering shaft. These splines force the wheel and shaft to turn as a unit, thereby transmitting turning force to the steering gear.

Removal

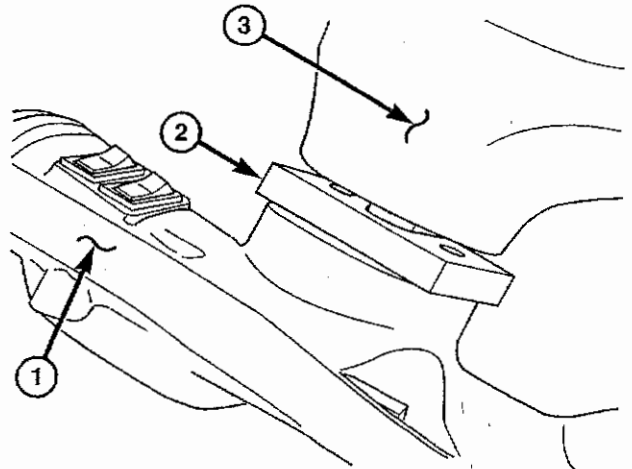

0038

Figure 8 - Puller U-Plate Placement

1. Instrument pod
2. U-plate
3. Steering wheel
9. Place the two small bolts through the upper plate of the puller. From the upper side of the steering wheel, run the two bolts through the steering wheel (Figure 9) and thread them into the U-shaped plate. Thread them in far enough to go through the U-shaped plate. (Figure 10)
10. Use appropriate wrench to turn the large bolt down against the threaded end of the steering shaft.
11. Tighten large bolt on puller until the steering wheel comes loose.
12. Remove Steering wheel.

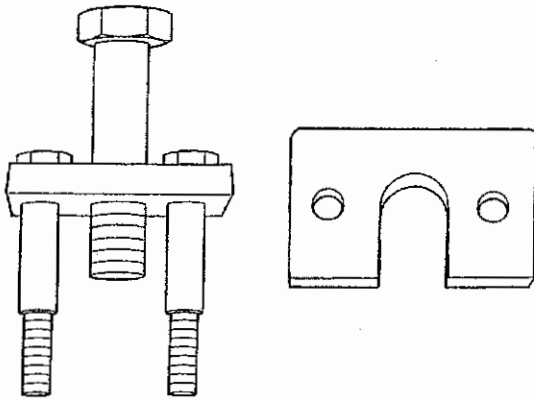

0037

Figure 7 - Steering Wheel Puller

1. Remove the mounting screws located on the underside of each side spoke of the steering wheel.
2. Remove steering wheel cover.
3. Remove attaching nut and washer from steering shaft.
4. Mark steering wheel and steering shaft end for reference when re-installing.
5. Remove the steering shaft/ rack and pinion attachment bolt.
6. Pull steering wheel away from the instrument panel as far as possible.
7. Separate the two halves of the puller.
8. Slide the U-shaped piece of the puller around the steering shaft, behind the steering wheel. (Figure 8)

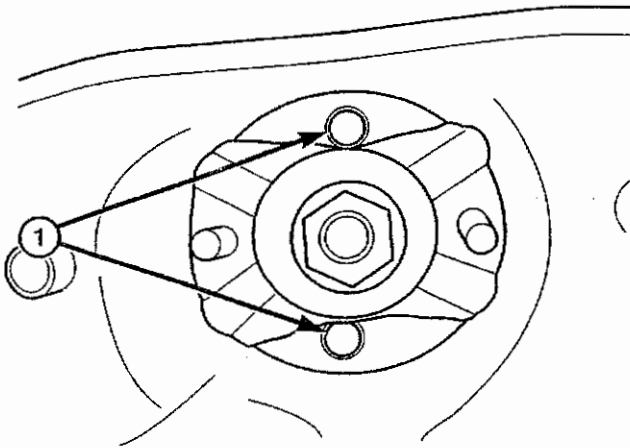

Figure 9 - Steering Wheel Holes For Puller

1. Guide holes

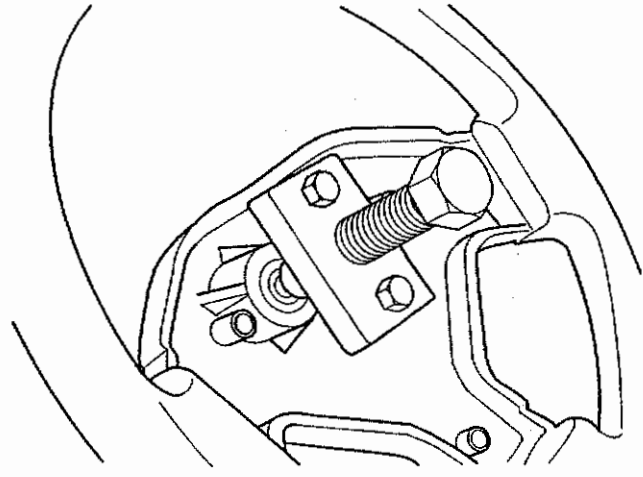

Figure 10 - Wheel Puller Installed

Installation

1. Using reference marks, align steering wheel to steering shaft and place on shaft.
2. Replace washer and attaching nut on end of shaft and tighten to press wheel completely on splines.
Back off nut and re-tighten to 225 inch-pounds.
3. Replace steering wheel cover and attach with mounting screws.

TORQUE SPECIFICATIONS

DESCRIPTION	THREAD SIZE	Use Loctite® 242	INCH-POUNDS	FOOT-POUNDS
Steering Wheel to Steering Shaft		NO	225	---

STEERING COLUMN ASSEMBLY

Description

The steering column consists of the steering column and steering shaft. It is bolted to the dash frame and supports the upper end of the steering shaft and steering wheel. The steering shaft is connected to the steering gear by a pinch bolt.

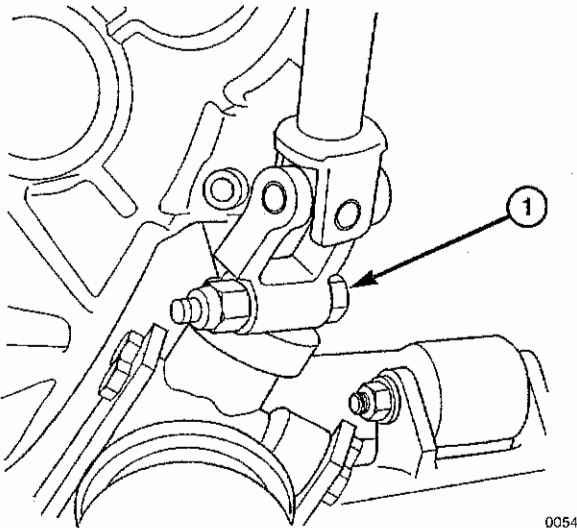

Figure 11 - Steering Shaft Pinch Bolt

1. Pinch Bolt

Removal

1. Remove upper dash assembly. (See UPPER DASH in BODY section.)
2. Remove lower dash assembly. (See LOWER DASH in BODY section.)
3. Remove steering column/instrument pod covers.
4. Remove steering wheel with wheel puller or appropriate method. (See STEERING WHEEL in this section.)
5. Loosen bolts attaching column to dash frame.
6. Raise vehicle off floor and support safely with jack stands.
7. Loosen pinch bolt attaching steering shaft to steering gear.
8. Pull shaft free of steering gear
9. Disconnect wires from instrument pod.
10. Remove previously loosened bolts attaching steering column to dash frame
11. Remove steering column

Cleaning and Inspection

Rotate steering shaft in bearing, feeling for roughness of action. If roughness is detected, replace steering shaft.

Inspect steering shaft u-joints and pinion mating surface for wear or damage. Replace shaft if necessary.

Installation

1. Position steering column assembly in dash and loosely attach to dash frame with mounting bolts.
2. Make sure that front wheels are straight, and that steering wheel is centered, then insert steering shaft over pinion gear stud on steering gear.

NOTE: When installing the pinch bolt that connects the steering shaft to the rack and pinion assembly, use a 1/8" spacer between the steering wheel and the instrument pod to maintain proper spacing (Figure 12).

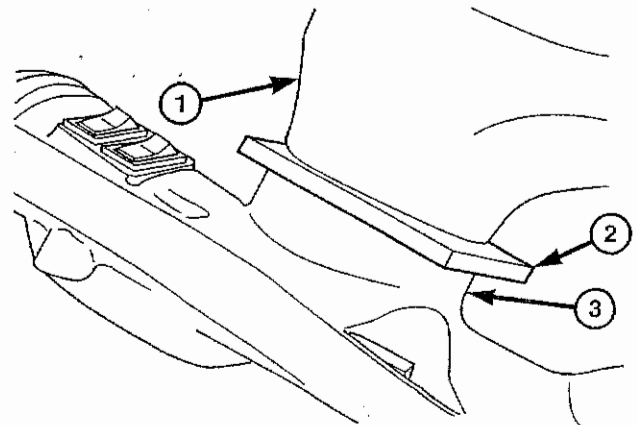

Figure 12 - Maintaining Proper Spacing

1. Steering wheel
 2. 1/8" spacer
 3. Instrument pod
1. Tighten pinch bolt to 30 foot-pounds..
 2. Lower vehicle to floor.
 3. Re-attach wires to instrument pod.\ (See INSTRUMENT POD in ELECTRICAL section.)
 4. Tighten steering column to dash support mounting bolts to 225 inch-pounds.
 5. Install steering wheel. (See STEERING WHEEL in this section.)
 6. Install instrument pod covers. (See INSTRUMENT POD in ELECTRICAL section.)
 7. Install lower dash panel. (See LOWER DASH PANEL in BODY section.)
 8. Install upper dash panel. (See UPPER DASH PANEL in BODY section.)

TORQUE SPECIFICATIONS

DESCRIPTION	THREAD SIZE	Use Loctite® 242	INCH-POUNDS	FOOT-POUNDS
Steering Column Pinch Bolt	3/8 - 16	NO	---	30
Steering Column to Dash Frame	5/16 - 18	NO	225	---
Steering Wheel to Steering Shaft		NO	225	---

STEERING GEAR**Description**

GEM uses a rack and pinion steering gear with integral tie rods.

Operation

Teeth on the pinion gear engage teeth on the rack. Turning motion of pinion gear causes rack to move either right or left.

Diagnosis and Testing

If excessive play was detected during the driving test outlined in FRONT WHEEL ALIGNMENT in this section, raise vehicle off ground and support safely with jack stands. Grasp lower half of steering shaft and rotate to determine if play is in the steering gear. Also check steering gear for loose mounting bolts.

- If the steering gear mounting bolts are loose, tighten to 225 inch-pounds.
- If excessive play is found within the steering gear, it must be replaced.

Removal

1. Remove hub-cap, loosen lug nuts.
2. Raise vehicle and support safely with jack stands.
3. Remove front wheel lug nuts and remove wheel.
4. Remove the tie rod ends with a 17mm socket or wrench. Use a 2-jaw puller to separate the tapered stud from the spindle.
5. Remove the pinch bolt that joins the steering column shaft and the steering gear. Slide the steering shaft up to disconnect it from the gear.
6. Remove the bolts and washers that attach the steering gear to the mounting bracket on the front suspension frame.
7. Removal of the steering gear requires the mounting bracket to be "opened up" to free the gear for removal. Have a helper support and remove the gear as the mounting bracket is gently opened with a pry-bar.

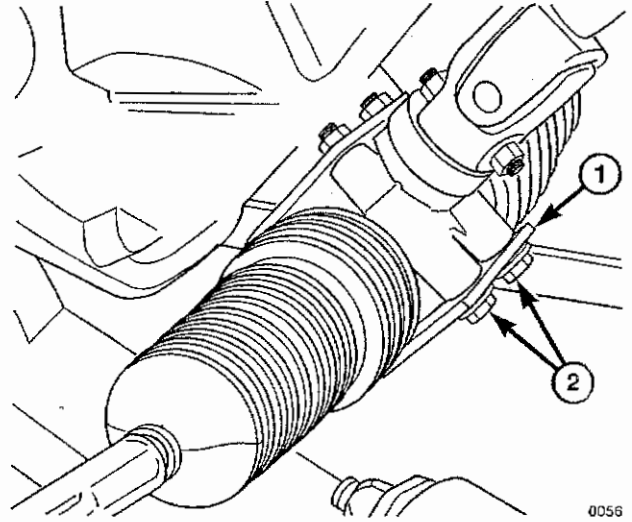

Figure 13 - Steering Gear Attaching Bolts

1. Bracket
2. Attaching bolts with up to four washers each (2 per side)

Installation

- 1) Position steering gear assembly in mounting bracket on front frame support. Attach with mounting bolts and tighten to 225 inch-pounds.
- 2) Make sure rack and pinion are in centered position (Tie rods are equal length).
- 3) Make sure steering wheel is in centered position, then insert lower end of steering shaft over pinion stud. Tighten pinch bolt to 30 foot-pounds.
- 4) Install outer tie rod ends. (See TIE ROD ENDS in this section.)
- 5) Install wheels, and tighten lug nuts just snug.
- 6) Lower vehicle to floor.
- 7) Tighten wheel lug nuts to 50 foot-pounds
- 8) Replace wheel cover
- 9) Check toe-in, adjust if necessary (See FRONT WHEEL ALIGNMENT in this section).

TORQUE SPECIFICATIONS

DESCRIPTION	THREAD SIZE	Use Loctite® 242	INCH-POUNDS	FOOT-POUNDS
Rack & Pinion to Frt. Suspension Frame	M8 x 1.25	NO	225	---
Steering Column Pinch Bolt	3/8 - 16	NO	---	30
Tie Rod Stud Nut	M10 x 1.5	NO	---	35
Wheel Lug Nuts	M10 x 1.5	NO	---	50

OUTER TIE ROD END

Description

The tie rod end provides the connection between the steering gear rack (tie rod) and the knuckle on the front wheel. Threads on the tie rod end allow adjustment of overall length and control toe-in. A jam nut maintains the tie rod end position relative to the tie rod.

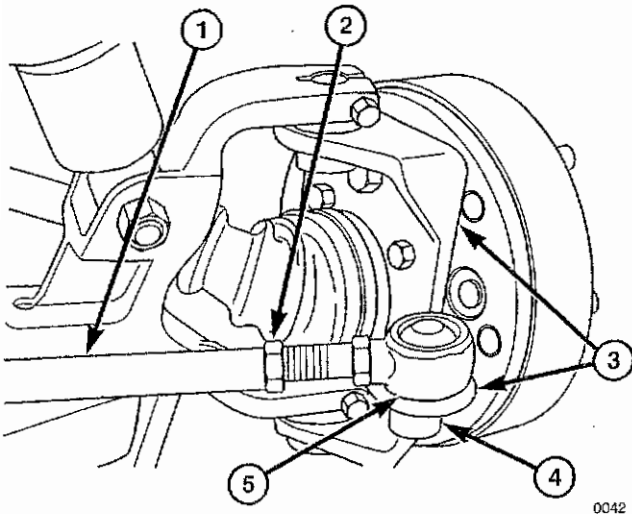

Figure 14 - Tie Rod End

1. Tie rod
2. Jam nut
3. Knuckle
4. Stud/Nut
5. Tie Rod End

Removal

1. Remove hub-cap and loosen lug nuts.
2. Raise front of vehicle and support safely with jack stands.
3. Remove lug nuts and wheel.
4. Loosen the tie rod jam nut.
5. Remove the nut from the bottom of the rod end stud where it attaches to the steering knuckle.
6. Use a 2-jaw puller to separate the tapered stud from the knuckle.
7. Unthread the outer tie rod end from the tie rod to remove.

Installation

1. Thread the new end into the tie rod to approximately the same depth as the old one.
2. Insert stud on tie rod end into steering knuckle and attach nut.
3. Tighten nut to seat stud in knuckle, then back off nut. Re-tighten nut to 35 foot-pounds.
4. Install wheel, and tighten lug nuts just snug.
5. Lower vehicle to ground.
6. Tighten wheel lug nuts to 50 foot-pounds.
7. Reset toe-in.
(See FRONT WHEEL ALIGNMENT in this section.)

TORQUE SPECIFICATIONS

DESCRIPTION	THREAD SIZE	Use Loctite® 242	INCH-POUNDS	FOOT-POUNDS
Tie Rod Stud Nut	M10 x 1.5	NO	---	35
Wheel Lug Nuts	M10 x 1.5	NO	---	50

KING PIN ASSEMBLY

Description

Two kingpins attach the steering knuckle to the yoke and provide the right-to left pivoting action of each wheel

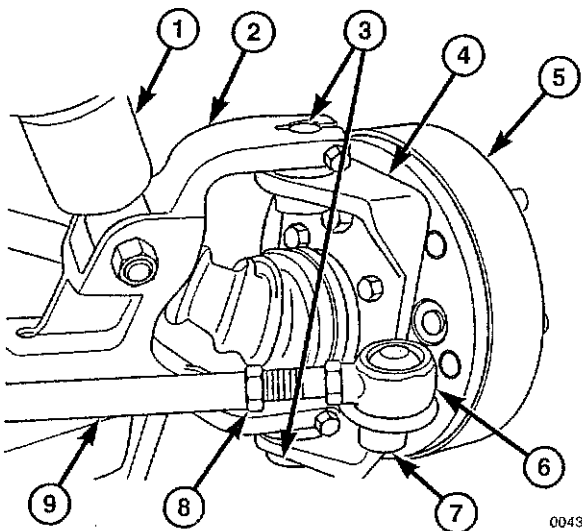

Figure 15 - Steering Components at Wheel

1. Shock absorber
2. Yoke
3. Kingpins
4. Knuckle
5. Wheel/Brake unit
6. Tie rod end
7. Tie rod end stud/nut
8. Tie rod end jam nut
9. Tie rod

Diagnosis and Testing

Worn kingpins can produce:

- Excessive play in steering,
- Tendency of the vehicle to wander,
- Tendency for the vehicle to pull in either direction under braking,
- Excessive front tire wear.

To determine if kingpins are worn:

1. Raise front of vehicle off floor and support safely with jack stands.
2. Grasp the knuckle at top and bottom and rock it up and down.
3. The kingpins must be replaced, as a set, if there is any perceptible motion in relation to the yoke.

Removal

1. Remove hub-cap and loosen wheel lugs
2. Raise vehicle off floor and support safely with jack stands.
3. Remove lug nuts and wheel.
4. Remove nut and washer from outboard end of half shaft.
5. Remove brake line, taking care to collect brake fluid in proper container for disposal.
6. Remove tie rod ends.
(See OUTER TIE ROD ENDS in this section.)
7. Remove pinch bolts securing yoke to kingpins.
8. Lift and remove knuckle.
9. Remove kingpin/bearing assembly with special keyed kingpin tool (#0112-00580 available from GEM) and 9/16" impact socket.

Installation

1. Insert kingpin/bearing assembly in knuckle.
2. Replace knuckle assembly in yoke.
3. Tighten bolts securing yoke to kingpins to 65 foot-pounds.
4. Replace tie rod ends. Tighten to 35 foot-pounds.
(See TIE ROD ENDS in this section.)
5. Replace brake line. Tighten to 37 foot-pounds.
6. Bleed brakes. (See BRAKE BLEEDING in BRAKES section.)
7. Replace washer and nut on outboard end of half shaft and tighten just snug.
8. Replace wheel and tire assembly. Tighten lug nuts until just snug.
9. Lower vehicle to floor.
10. Torque wheel lug nuts to 50 foot-pounds.
11. Back off half shaft nut slightly, add Loctite(r) 242 and tighten to 74 foot-pounds.
12. Replace wheel cover

TORQUE SPECIFICATIONS

DESCRIPTION	THREAD SIZE	Use Loctite® 242	INCH-POUNDS	FOOT-POUNDS
Brake line to Wheel/Master Cylinder		NO	---	37
Brake, Drum Assembly to Steering Knuckle	M8 x 1.25	NO	225	---
Half Shaft to Drum Brake Assembly	M16 x 1.5	YES	---	74
King Pin Pinch Bolt	M6 - 1	YES	65	---
Tie Rod Stud Nut	M10 x 1.5	NO	---	35
Wheel Lug Nuts	M10 x 1.5	NO	---	50

STEERING KNUCKLE**Description**

The knuckle is a single casting with legs machined for the upper and lower kingpins. It also has a machined surface for mounting the front drum brake assembly.

Operation

The steering knuckle pivots between the arms of the yoke on kingpins. Steering linkage attached to the knuckle allows the vehicle to be steered.

Removal

1. Remove hub-cap.
2. Loosen wheel lug nuts,
3. Loosen half-shaft retaining nut.
4. Raise vehicle off floor and support safely with jack stands.
5. Remove lug nuts and wheel
6. Remove half shaft nut.
7. Disconnect brake line at wheel cylinder.
8. Remove front drum brake assembly.
9. Mark thread locations of tie rod end at tie rod.
10. Remove nut from the bottom of the tie rod end stud where it joins the knuckle

11. Use a 2-jaw puller to separate tie rod end stud from knuckle.

12. Remove kingpin pinch bolts.

13. Lift knuckle up and pull away to remove from yoke.

Installation

- 1) Insert upper kingpin into yoke and lift knuckle assembly into place, allowing lower kingpin to drop into yoke.
- 2) Tighten kingpin pinch bolts to 65 foot-pounds.
- 3) Replace tie rod end stud in knuckle, tighten nut to seat stud in knuckle. Back nut off, then tighten to 35 foot-pounds.
- 4) Install front drum brake assembly. Tighten bolts to 225 inch-pounds.
- 5) Attach brake line to wheel cylinder, tighten to 37 foot-pounds, then bleed brakes.
- 6) Replace half shaft washer and bolt, tighten just snug
- 7) Replace wheel, tighten lug nuts just snug
- 8) Lower vehicle to ground, then tighten lug nuts to 50 foot-pounds.
- 9) Back off half shaft nut slightly, add Loctite(r) 242 and tighten to 74 foot-pounds.
- 10) Replace hub-cap.

TORQUE SPECIFICATIONS

DESCRIPTION	THREAD SIZE	Use Loctite® 242	INCH-POUNDS	FOOT-POUNDS
Brake line to Wheel/Master Cylinder		NO	---	37
Brake, Drum Assembly to Steering Knuckle	M8 x 1.25	NO	225	---
Half Shaft to Drum Brake Assembly	M16 x 1.5	YES	---	74
King Pin Pinch Bolt	M6 - 1	YES	65	---
Tie Rod Stud Nut	M10 x 1.5	NO	---	35
Wheel Lug Nuts	M10 x 1.5	NO	---	50

YOKE

Description

The yoke is a single casting that connects the steering knuckle to the lower control arm. It has two machined openings to receive the kingpins of the knuckle assembly. It allows the front suspension to pivot horizontally, thereby providing steering.

Removal

1. Remove hub-cap.
2. Loosen wheel lug nuts.
3. Loosen half-shaft retaining nut.
4. Raise vehicle off floor and safely support.
5. Remove lug nuts and wheel.
6. Disconnect brake line from wheel cylinder.
7. Remove half shaft nut.
8. Remove front drum brake assembly.
9. Remove knuckle assembly.
10. While providing support to control arm and yoke, remove the two bolts holding yoke to control arm.
11. Remove yoke.

Installation

1. Attach yoke to control arm with two bolts. Tighten to 60 foot-pounds.
2. Install knuckle assembly. Tighten kingpin pinch bolts to 65 inch-pounds. (See STEERING KNUCKLE in this section.)
3. Install front drum brake assembly. Tighten bolts to 225 inch-pounds.
4. Attach brake line to wheel cylinder, tighten to 37 foot-pounds, then bleed brakes.
5. Replace wheel, tighten lug nuts just snug.
6. Replace half shaft washer and bolt, tighten just snug.
7. Lower vehicle to ground, then tighten lug nuts to 50 foot-pounds.
8. Back off half shaft nut slightly, add Loctite 242 and tighten to 74 foot-pounds.
9. Replace hub-cap.

TORQUE SPECIFICATIONS

DESCRIPTION	THREAD SIZE	Use Loctite® 242	INCH-POUNDS	FOOT-POUNDS
Brake line to Wheel/Master Cylinder		NO	---	37
Brake, Drum Assembly to Steering Knuckle	M8 x 1.25	NO	225	---
Half Shaft to Drum Brake Assembly	M16 x 1.5	YES	---	74
King Pin Pinch Bolt	M6 - 1	YES	65	---
Tie Rod Stud Nut	M10 x 1.5	NO	---	35
Wheel Lug Nuts	M10 x 1.5	NO	---	50
Yoke to Control Arm	M12 x 1.75	NO	---	60

SPECIAL TOOLS

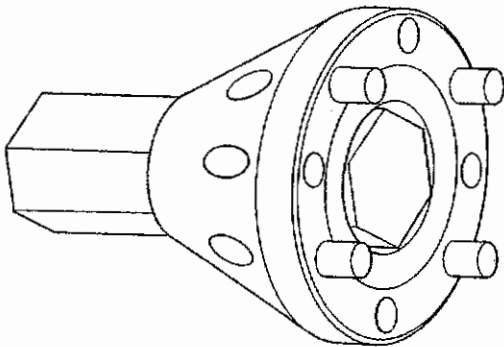

0065

Kingpin Tool - 0112-00580

CONTENTS

Description	3-2
Operation	3-2
Half Shaft	3-2
Differential	3-6



DRIVETRAIN

DESCRIPTION

The drive train consists of a 72-volt motor, a gearbox/differential and two constant velocity drive shafts called half shafts.

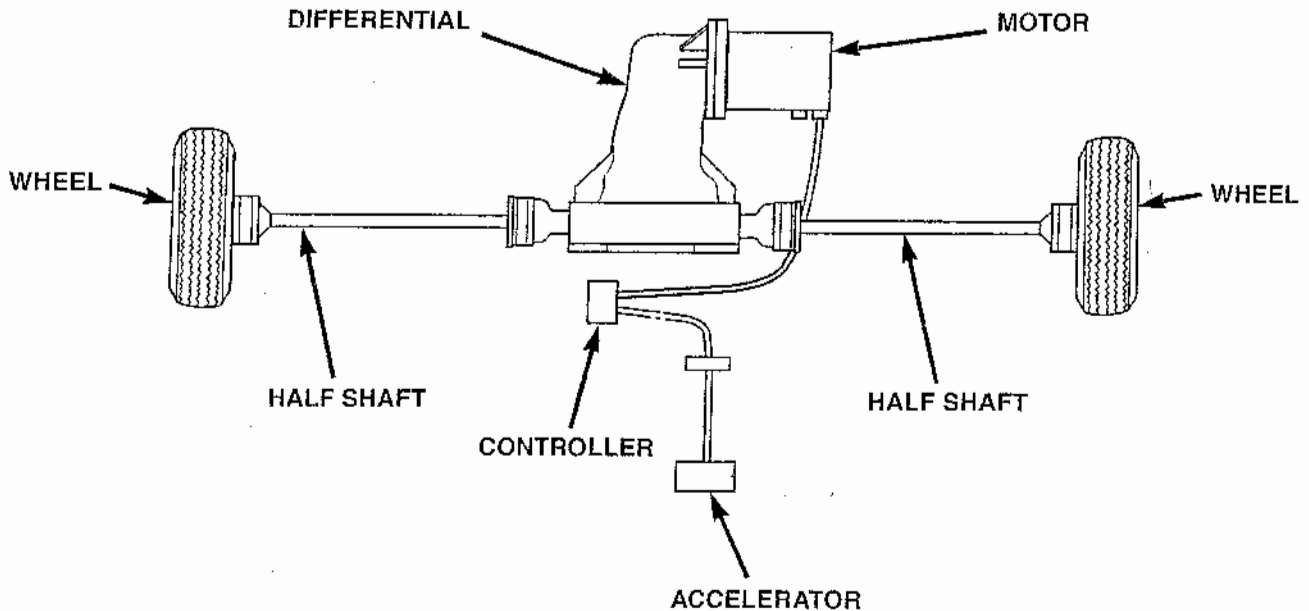

Figure 1 - Drivetrain

C044

OPERATION

Batteries power the motor. Motor speed is controlled by an accelerator pedal (potentiometer). The motor is connected to a differential. The power is transferred from the differential through two constant velocity (CV) drive shafts (half shaft) to the wheel hubs. The half shafts are identical and interchangeable.

NOTE: For instructions on motor and accelerator replacement/repair, see section 7.

During straight-ahead driving, the differential pinion gears do not rotate on the pinion mate shaft. This occurs because input torque applied to the gears is divided and distributed equally between the two side gears.

When turning corners, the outside wheel must travel a greater distance than the inside wheel to complete a turn. The difference must be compensated for to prevent the tires from scuffing and skidding through turns. To accomplish this, the differential allows the axle shafts to turn at unequal speeds:

HALF SHAFT

Description

The half shaft assembly consists of a shaft with rubber boots at each end for protection from dirt, etc. A splined socket on the inboard end of the shaft mates with a splined shaft on the differential. Splines on the outboard end of the shaft, mate with splines in the front wheel spindle.

Operation

Rotating motion of differential side gear is transferred to front wheel spindle by the half shaft.

Diagnosis

Half shafts must be replaced if they exhibit any of the following symptoms.

- A clicking noise in turns, which indicates that the outboard joint is damaged.

- A thump or clunk when accelerating from coasting, which points to a faulty inboard joint.
- Vibration or shuddering during acceleration, which may be caused by a damaged inboard or outboard joint, a sticking inboard joint, or an excessive operating angle.

Half shaft CV boots must be replaced if they exhibit grease accumulating around the outside of the boot. This is caused either by a small hole or a tear in the boot.

Removal

1. Remove lower bench seat cushion to access the Master Disconnect switch.
2. Switch master disconnect off.
3. Remove hubcaps.
4. Remove nut from outboard end of half shaft with 15/16-inch socket.
5. Loosen front wheel nuts.
6. Raise front of vehicle and support safely with jack stands.
7. Remove front wheel lug nuts and front wheel.
8. Remove upper bolt from front shock.
9. You will need assistance to remove the inner end of the half shaft that projects from the differential. The inner end is held on with a spring clip. Using a pair of short pry bars, gently force the inner end off the differential. Take care to not damage the splined shaft during this procedure.
10. Make sure the spring clip is still on splined shaft of differential and is not damaged. (If damaged, replace.)
11. Remove the outer end of the half shaft from the drum brake assembly.

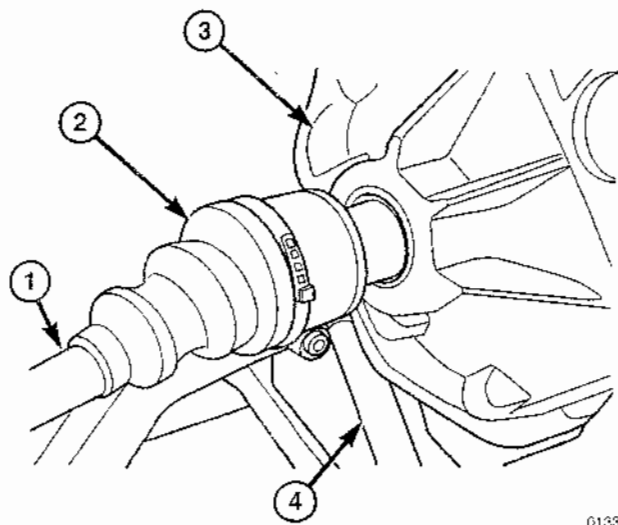

Figure 2 - Half Shaft Removal

1. Half Shaft
2. Inner Boot
3. Differential
4. Pry bar(s)

Cleaning and Inspection

Inspect half shafts. They must be replaced if they exhibit any of the following conditions: and boots for cuts. Discard and replace any boots found with cuts. Inspect splines on half shaft for wear or damage. If worn or damaged, replace the half shaft as it is not serviceable.

Disassembly

Secure half shaft in a vise

Outboard Boot

1. Use a small flat screwdriver to remove the large and small clamps from the outboard boot.

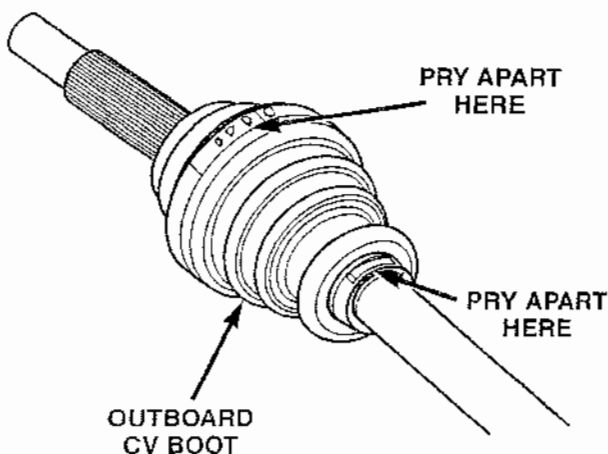

Figure 3 - Outboard Boot Clamp Removal

2. Push back outboard boot to expose snap ring connecting the spindle to the shaft.

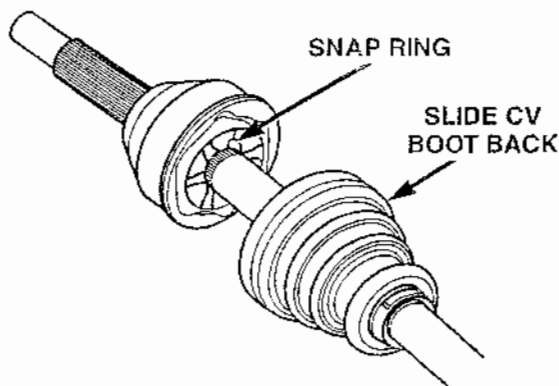

Figure 4 - Snap Ring Location

- Using snap ring pliers to release tension from snap ring, remove spindle assembly.

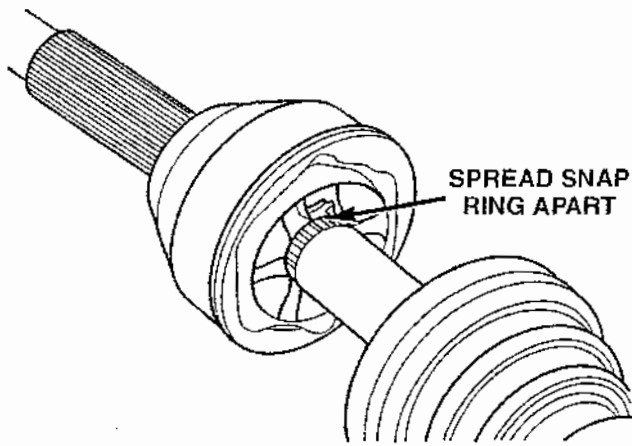

Figure 5 - Spindle Removal

- Slide damaged boot off the outboard end of the half shaft.
- Clean off grease and inspect spindle and half shaft for damage. Replace if damaged.

Inboard Boot

- Use a small flat screwdriver to remove the large and small clamps from the inboard boot.

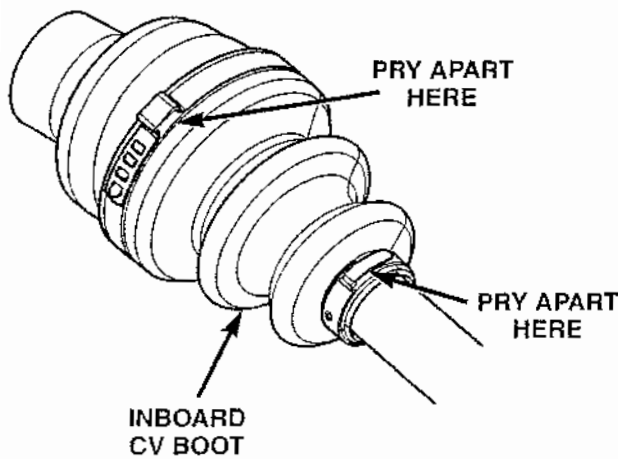

Figure 6 - Inboard Boot Clamp Removal

- Push back inboard boot to expose snap ring connecting inboard joint to the shaft.

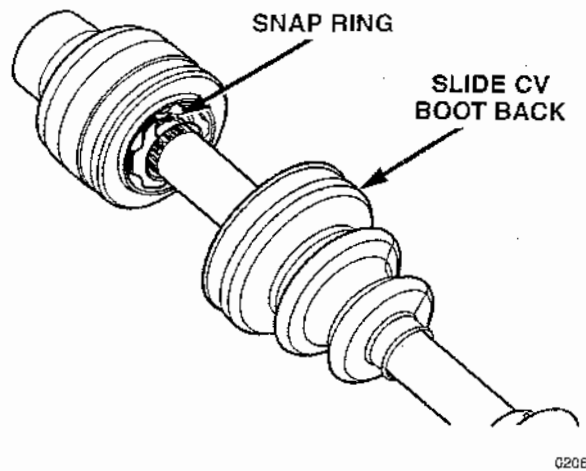

Figure 7 - Snap Ring Location

- Using snap ring pliers to release tension from snap ring, remove joint assembly.
- Slide damaged boot off the inboard end of the half shaft.
- Clean off grease and inspect joint and half shaft for damage. Replace if damaged.

Assembly

Outboard Boot

- Slide new outboard boot (P/N 0613-00196) onto the outboard end of the half shaft.
- Repack joint with Optimol Olistamoly 2 LN 584 LO grease.

NOTE: Use only Optimol Olistamoly 2 LN 584 LO grease or equivalent which meets NLGI grade 1 and 2 standards at all half shaft/boot locations. Never use ordinary chassis or wheel bearing grease.

- Push the spindle back onto the outboard end of the shaft and tap the joint until the snap ring is fully seated.
- Slide the large end of the boot over the spindle.
- Position large clamp (P/N 0613-00199) around large end of boot.
- Use the Lisle Boot Clamp Pliers (P/N LIS-30500) to secure clamp in place
- Position small clamp (P/N 0613-00261) so that raised punch marks face the boot. Wrap around small end of boot, feed narrow end of clamp into square hole at other end, then use channel lock pliers to tighten clamp.

Inboard Boot

1. Slide new inboard boot (P/N 0613-00195) onto the inboard end of the half shaft.
2. Repack joint with Optimol Olistamoly 2 LN 584 LO grease.
3. Push the inboard joint back onto the end of the shaft and tap the joint until the snap ring is fully seated.
4. Slide the large end of the boot over the inboard joint.
5. Position large clamp (P/N 0613-00198) around large end of boot.
6. Use the Lisle Boot Clamp Pliers (P/N LIS-30800) to secure clamp in place
7. Position small clamp (P/N 0613-00261) so that raised punch marks face the boot. Wrap around small end of boot, feed narrow end of clamp into square hole at other end, then use channel lock pliers to tighten clamp.

Installation

1. Apply Optimol Olistamoly 2 LN 584 LO grease or equivalent to the splines at the inner and outer end of the half shaft prior to installation.
2. Insert the outer end of the half shaft into the drum brake assembly.
3. Make sure the spring clip is still on splined shaft of differential and is not damaged
4. Install the inner end of the half shaft over the splined shaft on the differential. Press inward, toward differential until spring clip snaps into place.
5. Install upper front shock mounting bolt just snug.
6. Install washer and nut on half shaft outer end, tighten just snug.
7. Install front wheel with lug nuts. Tighten wheel lug nuts just snug.
8. Lower front of vehicle to ground.
9. Tighten spring/shock absorber mounting bolts to 60 foot-pounds.
10. Tighten wheel lug nuts to 50 foot-pounds.
11. Add Loctite 242 and torque half shaft nuts to 74 foot pounds:
12. Install hubcaps

Special Tools

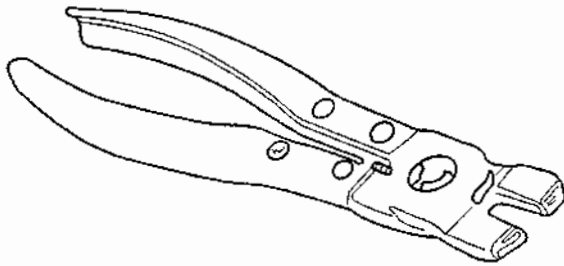

0202

Lisle CV Boot Clamp Pliers
(P/N LIS-30500)
Used on large outboard boot clamp.

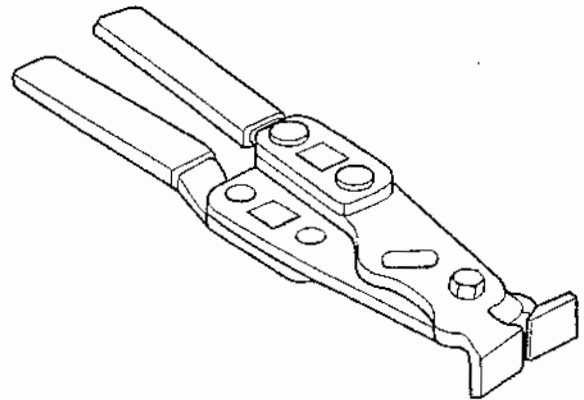

0203

Lisle CV Boot Clamp Pliers
(P/N LIS-30800)
Used on large inboard boot clamp.

Figure 8 - Clamp Pliers

TORQUE SPECIFICATIONS

DESCRIPTION	THREAD SIZE	Use Loctite® 242	INCH-POUNDS	FOOT-POUNDS
Half Shaft to Drum Brake Assembly	M16 x 1.5	YES	---	74
Shock Absorber Lower Bolt	M12 x 1.75	NO	---	60
Tie Rod Stud Nut	M10 x 1.5	NO	---	35
Wheel Lug Nuts	M10 x 1.5	NO	---	50

DIFFERENTIAL

Description

The differential consists of a pinion gear and two side gears in a cast aluminum case. The drive motor is attached to the pinion gear. The side gears are each attached to half shafts

Operation

Rotation of the motor spindle is transferred to the pinion gear. The pinion gear contacts the side gears, forcing them to rotate, transferring power to the half shafts.

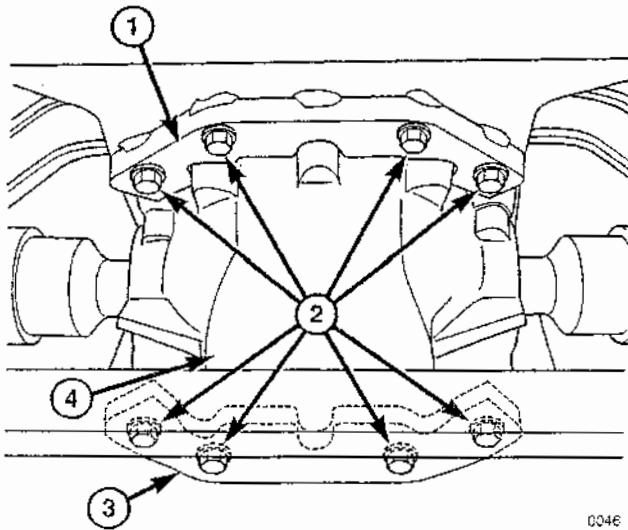

Figure 9 - Differential Mounting Bolts

1. Upper mounting bracket
2. Mounting bolts
3. Lower mounting bracket
4. Differential

Removal

1. Switch master disconnect to OFF.
2. Remove hubcaps.
3. Loosen lug nuts on front wheels.
4. Raise front of vehicle and support safely with jack stands.
5. Remove front wheel lug nuts and front wheels.
6. Remove upper bolts from front shocks. (Make sure front assembly is supported as releasing shocks will cause control arms to drop down.)
7. Remove half shafts. (See HALF SHAFT in this section.)

8. Remove motor. (See MOTOR in ELECTRICAL section.)
9. Remove steering shaft from steering gear (pinch-bolt). (See STEERING SHAFT in SUSPENSION & STEERING section.)
10. Make sure that both the frame and the front suspension frame are supported separately before going on. (Supports under the frame and a floor jack under the suspension frame works the best.)
11. Remove the two bolts attaching the front suspension frame to the body frame, lower the front suspension frame to provide clearance for the next steps.
12. While supporting the differential, remove the top four (4) bolts and upper mounting bracket that connect the differential to the suspension frame mounting plate.
13. Next, remove the bottom four (4) bolts and lower mounting bracket that connect the differential to the suspension frame.
14. Remove the differential by sliding it out the right (passenger) side

Installation

1. Add oil to new differential. (16oz. SAE30 weight)
2. Make sure that the spring clips are on the splined differential shafts.
3. Position differential between front suspension frame and mounting plate.
4. Install mounting brackets and bolts, 4 through the lower mounting bracket into the front suspension frame and 4 through the upper mounting bracket and plate. Torque differential mounting bolts to 225 inch-pounds.

NOTE: Do not over tighten as threads will strip.

5. Re-attach front suspension frame to body frame. (See FRONT SUSPENSION FRAME in SUSPENSION & STEERING section.)
6. Re-connect steering shaft to steering gear. (See STEERING SHAFT in SUSPENSION & STEERING section.)
7. Install motor. (See MOTOR in ELECTRICAL section.)
8. Install half shafts. Tighten nut just snug. (See HALF SHAFT in this section.)
9. Install spring/shock absorber upper mounting bolt. Tighten just snug.
10. Install front wheels, tighten lug nuts just snug.
11. Lower vehicle to ground.
12. Tighten spring/shock absorber upper mounting bolt to 60 foot-pounds.

13. Add Loctite 242 and torque half shaft nuts to 74 foot pounds.
14. Tighten wheel lug nuts to 50 foot pounds.
15. Replace hub caps
16. Switch master disconnect to ON.

TORQUE SPECIFICATIONS

DESCRIPTION	THREAD SIZE	Use Loctite® 242	INCH-POUNDS	FOOT-POUNDS
Differential to Frt. Suspension Frame	5/16" -- 18	NO	225	---
Half Shaft to Drum Brake Assembly	M16 x 1.5	YES	---	74
Motor to Differential	1/4 -- 20	YES	65	---
Shock Absorber Upper Bolt	M12 x 1.75	NO	---	60
Wheel Lug Nuts	M10 x 1.5	NO	---	50

CONTENTS

Brake System	4-2
Brake Bleeding	4-3
Standard Procedure - Manual - Bleeding	4-3
Pressure Bleeding	4-4
Front Brake Assembly	4-5
Rear Brake Assembly	4-7
Brake Pedal Assembly	4-8
Master Cylinder Assembly	4-9
Park Brake Lever Assembly	4-10
Parking Brake Cable Assembly	4-11
Park Brake Cable Tension Adjustment	4-12

BRAKES

BRAKE SYSTEM

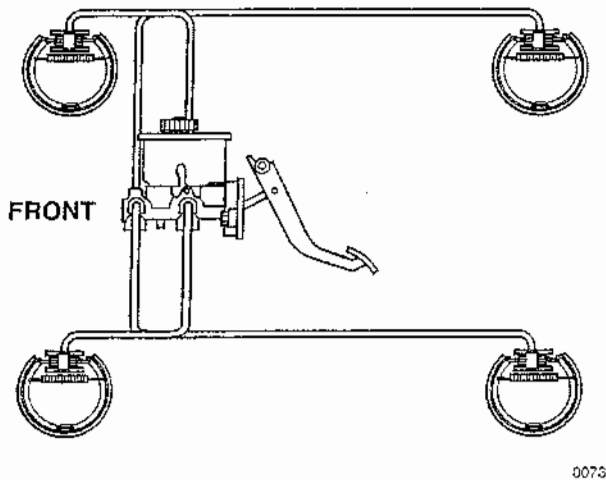

Figure _ 1 Hydraulic Brake System

DESCRIPTION

The GEM E825 utilizes a hydraulic brake system with drum brakes at all four wheels. Although the front drum brake assemblies are interchangeable, the rear drum brake assemblies are specific for RH and LH applications. There is also a mechanical parking brake that activates the rear brakes only.

OPERATION

Pressure on the brake pedal activates the brake light switch and causes a piston in the master cylinder to move inward, forcing brake fluid into the wheel cylinders via brake lines. The pistons in each wheel cylinder are forced out, causing the brake shoes to come into contact with the brake drums. When the park brake lever is pulled up, tension is placed on park brake cables attached to the rear drum brake assemblies, thereby activating them.

DIAGNOSIS

1. Check condition of tires and wheels. Damaged wheels and worn, damaged, or under-inflated tires can cause pull, shudder, vibration, and a condition similar to grab.
2. If complaint was based on noise when braking, check suspension components. Jounce front and rear of vehicle and listen for noise that might be caused by loose, worn or damaged suspension or steering components.

3. Inspect brake fluid level and condition. Note that the brake reservoir fluid level will decrease in proportion to normal lining wear.

NOTE: Brake fluid tends to darken over time. This is normal and should not be mistaken for contamination.

4. If fluid level is abnormally low, look for evidence of leaks at drum assemblies, hoses and lines, and master cylinder.
5. If fluid appears contaminated, drain out a sample to examine. System will have to be flushed if fluid is separated into layers, or contains a substance other than brake fluid. The system seals and cups will also have to be replaced after flushing. Use clean brake fluid to flush the system.
6. Check park brake operation. Verify free movement and full release of cables and lever. Also note if vehicle was being operated with park brake partially applied.
7. Check brake pedal operation. Verify that pedal does not bind and has adequate free play. If pedal lacks free play, check pedal for being loose or for bind condition. Do not road test until condition is corrected.
8. If components checked appear OK, road test the vehicle
9. During road test, make normal and firm brake stops in 10-20 mph range. Note faulty brake operation such as low pedal, hard pedal, fade, pedal pulsation, pull, grab, drag, noise, etc.
10. Attempt to stop the vehicle with the parking brake only and note grab, drag, noise, etc.

Pedal Falls Away

A brake pedal that falls away under steady foot pressure is generally the result of a system leak. The leak point could be at a brake line, fitting, hose, or wheel cylinder. If leakage is severe, fluid will be evident at or around the leaking component. Internal leakage (seal by-pass) in the master cylinder caused by worn or damaged piston cups, may also be the problem cause.

Low Pedal

If a low pedal is experienced, pump the pedal several times. If the pedal comes back up, worn linings, drums, or rear brakes out of adjustment are the most likely causes. The proper course of action is to inspect and replace all worn component and make the proper adjustments.

Spongy Pedal

A spongy pedal is most often caused by air in the system. However, thin brake drums or substandard brake lines and hoses can also cause a spongy pedal. The proper course of action is to bleed the system, and replace thin drums and substandard quality brake hoses if suspected.

Hard Pedal or High Pedal Effort

A hard pedal or high pedal effort may be due to lining that is water soaked, contaminated, glazed, or badly worn. The check valve could also be faulty. Pedal Pulsation Pedal pulsation is caused by components that are loose, or beyond tolerance limits. The primary cause of pulsation is out of round brake drums. Other causes are loose wheel bearings and worn, damaged tires.

Brake Noises

Some brake noise is common with drum brakes during the first few stops after a vehicle has been parked overnight or stored. This is primarily due to the formation of trace corrosion (light rust) on metal surfaces. This light corrosion is typically cleared from the metal surfaces after a few brake applications causing the noise to subside.

Brake Squeak or Squeal

Brake squeak or squeal may be due to linings that are wet or contaminated with brake fluid, grease, or oil. Glazed linings and rotors with hard spots can also contribute to squeak. Dirt and foreign material embedded in the brake lining will also cause squeak/ squeal. A very loud squeak or squeal is frequently a sign of severely worn brake lining. If the lining has worn through to the brake shoes in spots, metal-to-metal contact occurs. If the condition is allowed to continue, drums can become so scored that replacement is necessary.

Brake Chatter

Brake chatter is usually caused by loose or worn components, or glazed/burnt lining. Additional causes of chatter are brake lining not securely attached to the shoes, loose wheel bearings and contaminated brake lining.

Thump or Clunk Noise

Thumping or clunk noises during braking are frequently not caused by brake components. In many cases, such noises are caused by loose or damaged steering, suspension, or engine components. However, worn out, improperly adjusted, or improperly assembled brake shoes can also produce a thump noise.

BRAKE BLEEDING

Brakes must be bled to remove air from the system whenever the brake hoses or brake lines are disconnected.

BLEEDING THE BRAKE SYSTEM

NOTE: Proper brake bleeding requires an automotive type pressure bleeder or vacuum bleeder. Good quality units are available from reputable automotive tool companies.

WARNING!

Brake fluid is toxic and must be properly disposed. Follow instructions on brake fluid container in the event of accidental contact or ingestion.

CAUTION!

Use only DOT3 brake fluid from an unopened container.

CAUTION!

Brake fluid will remove paint. Immediately clean up any fluid that gets on a painted surface.

STANDARD PROCEDURE - MANUAL -BLEEDING

Use brake fluid, or an equivalent quality fluid meeting DOT 3 standards only. Use fresh, clean fluid from a sealed container at all times.

1. Remove reservoir filler cap and fill reservoir.
2. If wheel cylinders were overhauled, open all wheel cylinder bleed screws. Then close each bleed screw as fluid starts to drip from it. Top off master cylinder reservoir once more before proceeding.

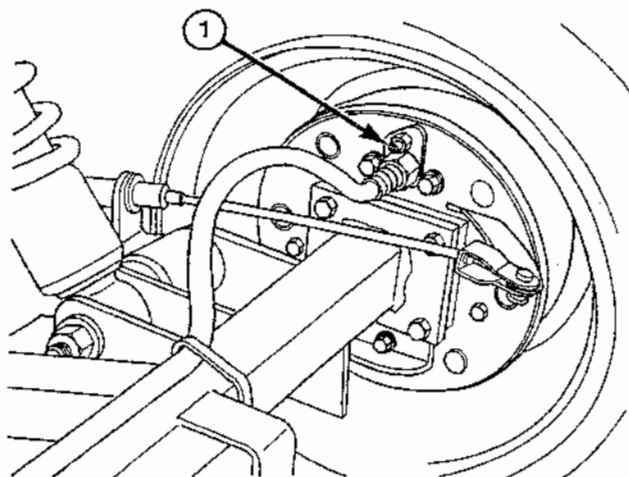

0025

Figure 3 - Bleed Screw (Typical)

1. Bleed Screw

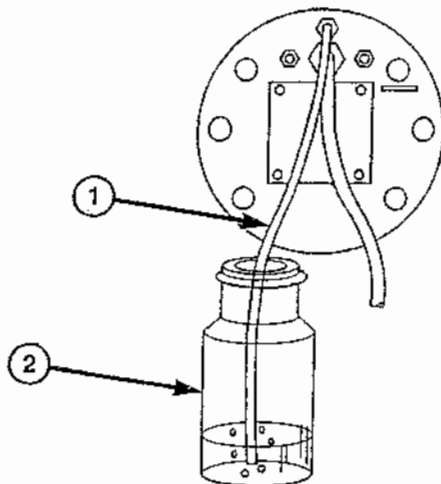

0024

Figure 4 - Brake Bleeding Setup

1. Hose
2. Container for waste brake fluid

3. Starting at the right rear brake drum assembly, attach one end of bleed hose to bleed screw and insert opposite end in glass container partially filled with brake fluid (Fig. 4). Be sure end of hose is immersed in fluid.
4. Have a helper pump the brake pedal 4-5 times, then hold the brake pedal down.
5. Once the pedal is down, open the bleeder and let the air out. Close the bleeder and then release the brake pedal.
6. Repeat steps 4 and 5 until fluid stream is clear and free of bubbles.
7. Then move, in turn, to the left rear, right front, then left front drum brake assemblies and repeat steps 1-6.

PRESSURE BLEEDING

1. Follow the bleeder unit instructions for attachment and use.
2. Always ensure that the brake fluid reservoir in the master cylinder is kept at the "MAX" fill line while bleeding.
3. Bleed the system at all four wheels. Start at right rear brake drum assembly. Continue on to left rear, then right front, then left front.
4. After bleeding all four wheels, apply pressure to brake pedal. Pedal should have a firm feel and not contact the floor even under maximum effort. If pedal feels mushy, or makes contact with the floor, repeat steps 1-3.
5. Check bleed-screws and hose/line connections for leaks.
6. Double check brake fluid level in master cylinder reservoir, and fill if necessary.
7. Test drive vehicle to ensure that the brakes work properly, and vehicle does not pull to left or right during braking.

FRONT BRAKE ASSEMBLY

DESCRIPTION

The front brake assembly consists of a spindle, wheel cylinder, drum and shoes. It is mounted on the steering knuckle. A half shaft (drive shaft) engages splines on the spindle, and is attached by a nut and washer.

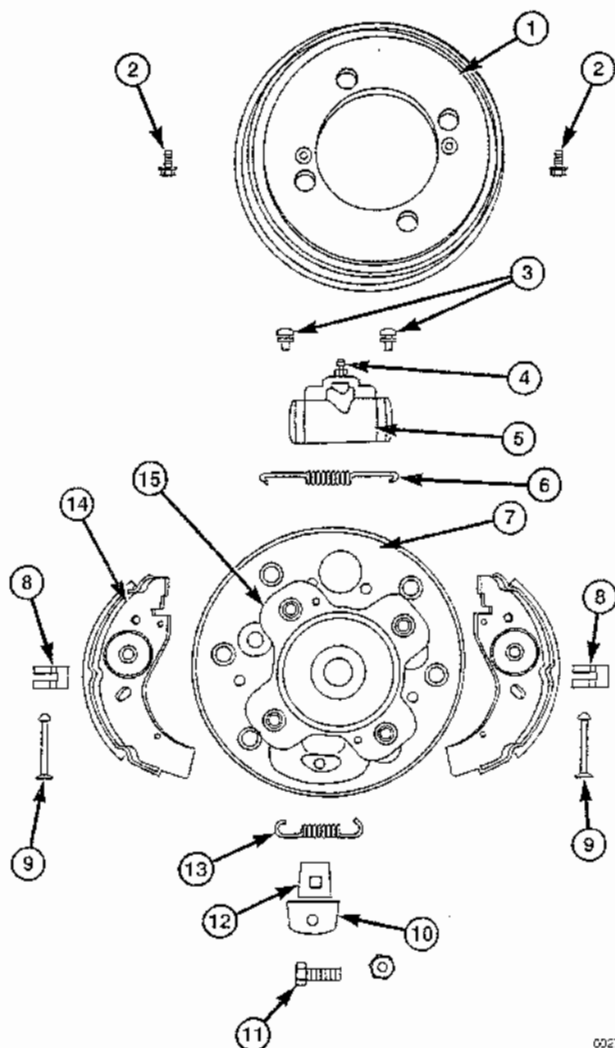

Figure 5 - Front Brake Breakdown
(* indicates serviceable part)

1. Drum*
2. Drum mounting bolt(s)*
3. Wheel cylinder mounting bolt(s)*
4. Bleed screw *
5. Wheel cylinder*
6. Upper spring
7. Mounting/Backing plate

8. Retention pin clip(s)
9. Brake shoe retention pin(s)
10. Lower shoe retainer
11. Spacer/retainer mounting bolt and nut
12. Spacer
13. Lower spring
14. Brake shoe(s)*
15. Spindle

OPERATION

Pressure on the brake pedal, forces brake fluid through the brake line, from the master cylinder to the wheel cylinder. The wheel has two pistons each of which engage a brake shoe. This pressure pushes the pistons out, causing the brake shoes to press against the brake drum. The resulting friction causes the drum and wheel to stop turning.

REMOVAL

1. Pry off wheel cover with standard screwdriver.
2. Loosen wheel lug nuts and drive shaft retaining nut.
3. Raise vehicle off floor and properly support.
(See JACKING in INTRODUCTION Section.)
4. Remove 19mm wheel lugs
5. Remove 15/16" drive shaft retaining nut.
6. Using a flare wrench, remove 17mm brake line from wheel cylinder and allow fluid to drain into suitable container for disposal.

NOTE: The use of flare nut wrenches reduces damage to brake fittings. Good quality flare nut wrenches are available from reputable automotive tool companies.

7. Remove the four 13mm mounting bolts attaching the front brake assembly to the steering knuckle.
8. Remove front brake assembly.

DISASSEMBLY

1. Remove two Allen head screws holding drum to assembly, remove drum.
2. Remove spring clips from retaining pins at center of each shoe, and remove pins.
3. Insert screwdriver between shoe and spring, using lower pivot point as a fulcrum. Remove lower spring.

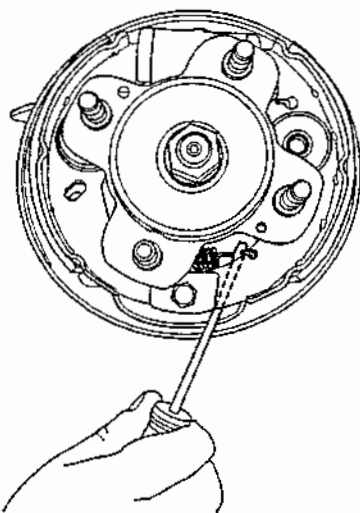

Figure 6 - Lower Spring Removal

0026

NOTE: Make sure that pads properly engage wheel cylinder pistons.

3. Replace upper and lower springs.
4. Replace shoe retention pins and clips.
5. Replace lower pivot point spacer with narrow side up, then replace retainer with rounded side down. Attach with bolt and nut.
6. Replace drum, attach with Allen head screws.

INSTALLATION

1. Position front brake assembly on steering knuckle, attach with four 13mm bolts.
2. Using a flare nut wrench, attach 17mm brake line to wheel cylinder
3. Bleed brakes. (See Brake Bleeding instructions in this section.)
4. Install 15/16" drive shaft retaining nut and washer, tighten just snug.
5. Install wheel. Attach with lug nuts, tighten just snug.
6. Lower vehicle to ground
7. Back off drive shaft retaining nut, apply Loctite 242(r) and re-tighten to 74 foot pounds
8. Tighten wheel lug nuts to 50 foot-pounds.
9. Replace wheel cover.

4. Remove bolt, retaining plate and spacer at lower pad pivot point.
5. Remove upper spring. 6. Lift pads away from wheel cylinder and off center locating post. 7. Remove two bolts attaching wheel cylinder. 8. Remove wheel cylinder.

ASSEMBLY

1. Position wheel cylinder on backing plate and attach with mounting bolts.
2. Position shoes over posts on backing plate

TORQUE SPECIFICATIONS

DESCRIPTION	THREAD SIZE	Use Loctite® 242	INCH-POUNDS	FOOT-POUNDS
Brake line to Wheel/Master Cylinder		NO	---	37
Brake, Drum Assembly to Steering Knuckle	M8 x 1.25	NO	225	---
Half Shaft to Drum Brake Assembly	M16 x 1.5	YES	---	74
Wheel Lug Nuts	M10 x 1.5	NO	---	50

REAR BRAKE ASSEMBLY

DESCRIPTION

The rear brakes consist of a spindle, wheel cylinder, park brake actuator lever, drum and shoes. It is mounted on flanges at each end of the rear axle. The park brake actuator lever is connected by cables to the park brake lever.

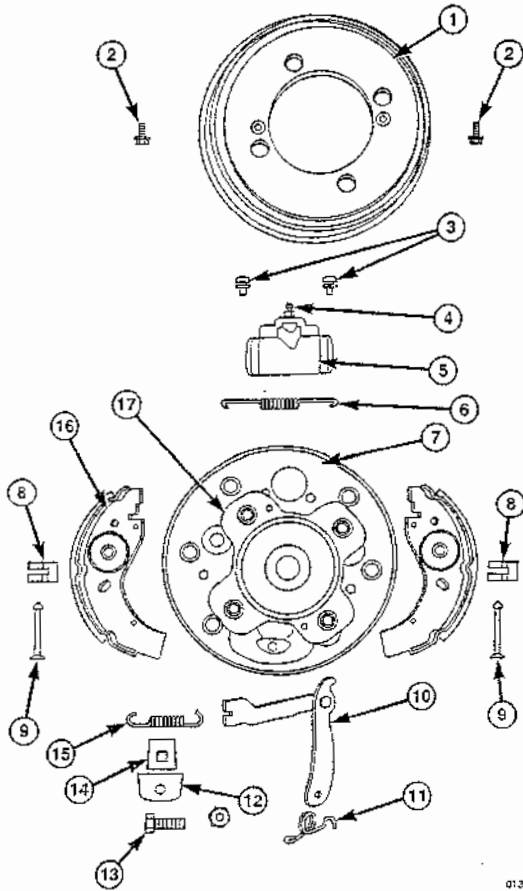

Figure 7 - Rear Brake Breakdown
(* indicates serviceable part)

1. Drum*
2. Drum mounting bolt(s)*
3. Wheel cylinder mounting bolt(s)*
4. Wheel cylinder*
5. Bleed screw*
6. Upper spring
7. Mounting/Backing plate
8. Spindle
9. Brake shoe(s)*
10. Brake shoe retention pin(s)
11. Retention pin clips
12. Lower spring
13. Spacer
14. Lower shoe retainer
15. Spacer/retainer mounting bolt and nut*

OPERATION

Pressure on the brake pedal forces brake fluid through the brake line from the master cylinder to the wheel cylinder. The wheel cylinder has two pistons each of which engage a brake shoe. Fluid pressure pushes the pistons out, causing the brake shoes to press against the brake drum.

When the park brake lever is engaged, it pulls on the cables to the park brake actuator lever, which engages the two brake shoes. Movement of the park brake actuator forces the brake shoes to press against the brake drum.

The friction of the shoes against the drum causes the drum and wheel to stop turning.

REMOVAL

1. Raise vehicle off floor and support with jack stands (See JACKING in INTRODUCTION section).
2. Pry off wheel cover with standard screwdriver.
3. Remove 19mm wheel lugs.
4. Using flare nut wrench, remove 17mm brake line from wheel cylinder and allow fluid to drain into suitable container for disposal.
5. Remove the four 13mm bolts attaching brake assembly to axle end flange.
6. Remove rear brake assembly and support while disconnecting park brake cable.
7. Remove cotter pin and clevis pin attaching park brake cable to actuator lever on brake drum.
8. Pull park brake cable from actuator lever.

DISASSEMBLY

1. Remove two Allen head screws holding drum to assembly, remove drum
2. Remove spring clips from pins at center of each shoe, and remove pins.
3. Insert screwdriver between shoe and spring, using lower pivot point as a fulcrum, remove lower spring
4. Remove bolt, retaining plate and spacer at lower pad pivot point
5. Remove upper spring
6. Lift pads away from wheel cylinder and off center locating post.
7. Remove two bolts attaching wheel cylinder and park brake actuator return spring
8. Remove wheel cylinder, spring and park brake actuator lever.

ASSEMBLY

1. Replace park brake actuator lever.
2. Position wheel cylinder on backing plate and attach with mounting bolt furthest from actuator lever.
3. Position park brake actuator lever spring, making

sure it engages lever and is directly over mounting hole in wheel cylinder, then insert last mounting bolt and tighten.

4. Position trailing shoe first
5. Position leading shoe

NOTE: Make sure that park brake actuator lever properly engages the brake shoes

NOTE: Make sure that pads properly engage wheel cylinder pistons

6. Replace upper and lower springs
7. Replace shoe retention pins and clips
8. Replace lower pivot point spacer with narrow side up, then replace retainer with rounded side down. Attach with bolt and nut.
9. Replace drum, attach with Allen head screws.

INSTALLATION

1. Be sure you have correct (RH or LH) drum brake assembly.
2. Insert parking brake cable into park brake actuator lever.
3. Insert clevis pin into park brake actuator lever, making sure park brake cable is engaged, secure with cotter pin.
4. Replace the four 13mm bolts through the rear axle end into the spindle on rear of brake assembly. Tighten bolts to 225 inch-pounds.
5. Using flare nut wrench, attach 17mm brake line to wheel cylinder.
6. Replace 19mm wheel lugs. Tighten to 50 ft.lbs.
7. Replace wheel cover.
8. Bleed brakes. (See Brake Bleeding instructions in this section.)

TORQUE SPECIFICATIONS

DESCRIPTION	THREAD SIZE	Use Loctite® 242	INCH-POUNDS	FOOT-POUNDS
Brake line to Wheel/Master Cylinder		NO	---	37
Brake, Drum Assembly to Steering Knuckle	M8 x 1.25	NO	225	---
Wheel Lug Nuts	M10 x 1.5	NO	---	50

BRAKE PEDAL ASSEMBLY

DESCRIPTION

The brake pedal assembly is mounted on the dash support frame. It consists of the brake pedal, bracket, push rod, brake light switch, and brake failure light switch.

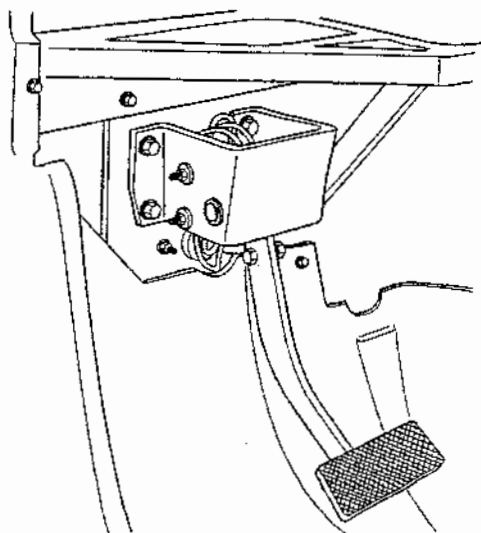

Figure 8 - Brake Pedal Assembly

OPERATION

The brake pedal pivots on a shaft mounted on the bracket. Foot pressure causes downward motion of the pedal, forcing a push rod against a piston in the master cylinder. When foot pressure against brake pedal is released, a return spring forces the pedal (and push rod) back to its original position, relieving pressure in master cylinder.

REMOVAL

1. Remove upper and lower dash panels. See DASH PANEL UPPER and DASH PANEL LOWER in BODY section.)
2. Remove wires from brake light switch (uppermost on bracket). Blue/Brown wire from left terminal, Orange and Orange/Red combined from right terminal
3. Remove wires from brake failure light switch (lowermost on bracket). Blue/Brown wire from left terminal, Orange/Red from right terminal
4. Remove four bolts attaching pedal assembly to dash support frame
5. Remove brake pedal assembly.

TORQUE SPECIFICATIONS

DESCRIPTION	THREAD SIZE	Use Loctite® 242	INCH-POUNDS	FOOT-POUNDS
Brake Pedal Assembly to Frame	5/16 - 18	NO	225	---
Brake Pedal to Push Rod	3/8 - 16	NO	---	30

INSTALLATION

1. Position brake pedal assembly on dash support frame, making sure push rod passes through bellows and properly engages master cylinder piston.
2. Attach pedal assembly to dash support frame with four mounting bolts. Tighten to 225 inch-pounds.
3. Re-connect wires to brake failure light switch (blue wire to left terminal, orange/red wire to right terminal).
4. Re-connect wires to brake light switch (blue/brown wire to left terminal, orange and orange/red wire to right terminal).
5. Install lower dash panel.
6. Install upper dash panel.

MASTER CYLINDER ASSEMBLY

DESCRIPTION

The master cylinder assembly is located under the hood on the left frame rail, next to the steering column. A plastic reservoir on top of the master cylinder holds additional brake fluid for proper operation.

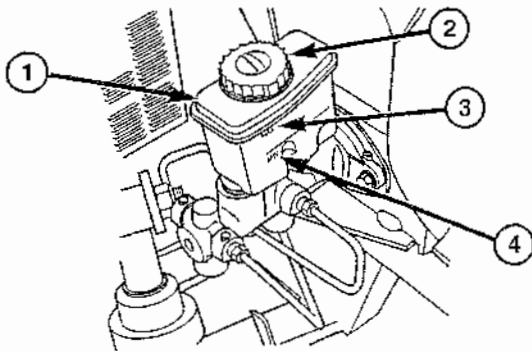

0012

Figure 9 - Master Cylinder

1. Reservoir
2. Cap
3. Maximum fluid level line
4. Minimum fluid level line

OPERATION

Pressure from the brake pedal is transmitted by a push rod to a piston in the master cylinder, causing the piston to move forward. Movement of piston forces brake fluid out of master cylinder into brake lines leading to the four brake assemblies.

REMOVAL

1. Chock wheels.
2. Using a flare nut wrench, remove brake lines from master cylinder. Take care to capture brake fluid in proper container for disposal.
3. Remove two mounting bolts attaching master cylinder to cowl.
4. Remove master cylinder and mounting gasket.

INSTALLATION

1. Position master cylinder and mounting gasket on cowl.
2. Attach with two mounting bolts and nuts. Tighten to 225 inch-pounds.
3. Attach brake lines to master cylinder.
4. Add DOT3 brake fluid to master cylinder reservoir until FULL line on side of reservoir is reached.
5. Bleed brakes. (See BRAKE BLEEDING in this section.)

TORQUE SPECIFICATIONS

DESCRIPTION	THREAD SIZE	Use Loctite® 242	INCH-POUNDS	FOOT-POUNDS
Brake line to Wheel/Master Cylinder		NO	---	37
Brake Master Cylinder to Frame	5/16 - 18	NO	225	---

PARK BRAKE LEVER ASSEMBLY

DESCRIPTION

The park brake lever is located between the driver and front passenger seats. On four-passenger models, it is mounted on top of the front seat tub. On all other models, it is mounted on the front of the bench seat tub.

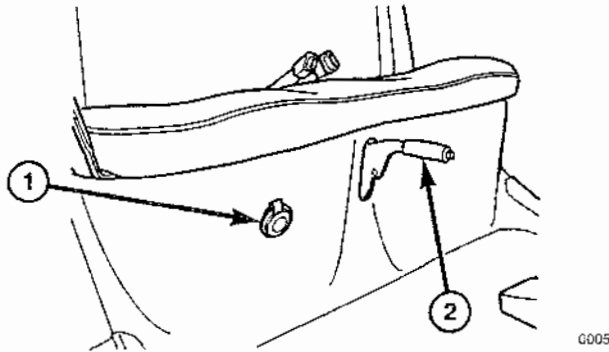

Figure 10 - Park Brake Lever

1. Charge Receptacle 2. Park brake lever

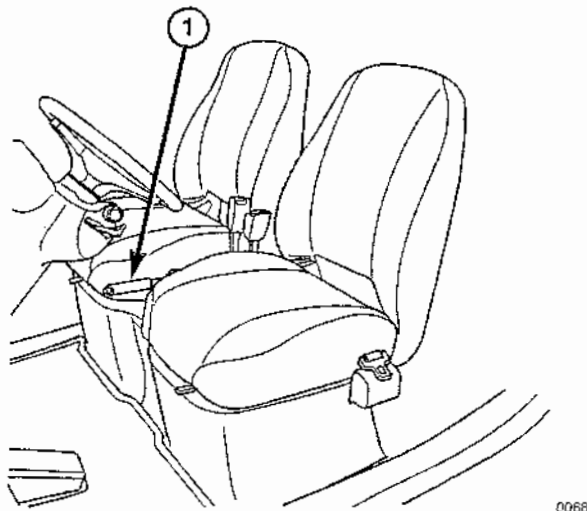

Figure 11 - Park Brake Lever (4 Passenger)

1. Park brake lever

OPERATION

Pulling up on lever causes the park brake adjuster assembly to pull on the park brake cables. A ratchet holds the park brake lever in place, maintaining pressure on the cables. A push button on the end of the park brake cable disengages the ratchet, allowing the lever to be returned to its normal position, thereby releasing the tension on the cables.

REMOVAL

WARNING!

Use caution when working near batteries. Always switch master disconnect off and cover battery terminals to prevent electrical shock. Accidental contact with battery terminals can result in damage or personal injury.

Two-Passenger, Short Bed Utility, Long Bed Utility Models

1. Chock wheels
2. Remove lower seat. (See BENCH SEAT in BODY section.)
3. Switch master disconnect off, and cover battery terminals to prevent electrical contact.
4. Release park brake.
5. Locate threaded adjusting rod/cable at the end of the lever.
6. Using 1/2" open wrenches, remove jam and adjusting nuts from adjusting rod.
7. Remove park brake switch connections.
8. Locate and remove mounting bolts from park brake lever brackets with 1/2" wrench or socket
9. Remove park brake lever assembly.

Four-Passenger Model

1. Chock wheels
2. Remove parking brake lever boot.
3. Release park brake.
4. Locate threaded adjusting rod/cable at the end of the lever.
5. Using 1/2" open wrenches, remove jam and adjusting nuts from adjusting rod.
6. Remove park brake switch connections.
7. From underneath vehicle, remove mounting bolts from park brake lever brackets with 1/2" wrench or socket
8. Remove park brake lever assembly.

INSTALLATION

Two-Passenger, Short Bed Utility, Long Bed Utility Models

1. Position park brake lever assembly.
2. Replace mounting bolts through park brake lever brackets.
3. Re-connect park brake switch wires to proper terminals on switch: Yellow/green on lowest most rearward terminal, white/green on center terminal, and green on upper (most forward) terminal.

4. Insert adjusting rod into park brake cable equalizer, replace adjusting and jam nuts.
5. Adjust tension on park brake cables. (See Park Brake Cable Tension Adjustment, below.)
6. Install lower seat. (See seat installation in Body section.)

Four-Passenger Model

1. Position park brake lever assembly.
2. Replace mounting bolts through park brake lever brackets.
3. Re-connect park brake switch wires to proper terminals on switch: Yellow/green on lowest most rearward terminal, white/green on center terminal, and green on upper (most forward) terminal.
4. Insert adjusting rod into park brake cable equalizer, replace adjusting and jam nuts.
5. Adjust tension on park brake cables. (See Park Brake Cable Tension Adjustment, below.)
6. Install parking brake lever boot.

PARKING BRAKE CABLE ASSEMBLY

DESCRIPTION

Two cables are attached to the park brake lever by a tension equalizer and to the park brake actuator levers on the rear brake assemblies.

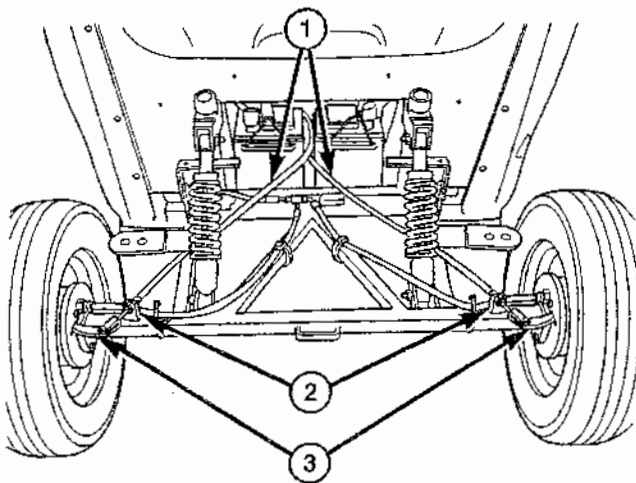

Figure 12 - Park Brake Cables

1. Park brake cables
2. Cable mounting bracket
3. Actuator lever

REMOVAL

1. Chock wheels
2. Remove lower seat. (See seat removal in Body section.)
3. Switch master disconnect off, and cover battery terminals to prevent electrical contact.
4. Release park brake lever.
5. Remove cables from the equalizer
6. Remove spat (see Spat Removal in Body section), exposing rear park brake cable attachments.
7. Remove cotter pin and clevis pin from rear brake drum assembly
8. Remove retaining rings from rear mounting points.
9. Pull cable back and downward to release.

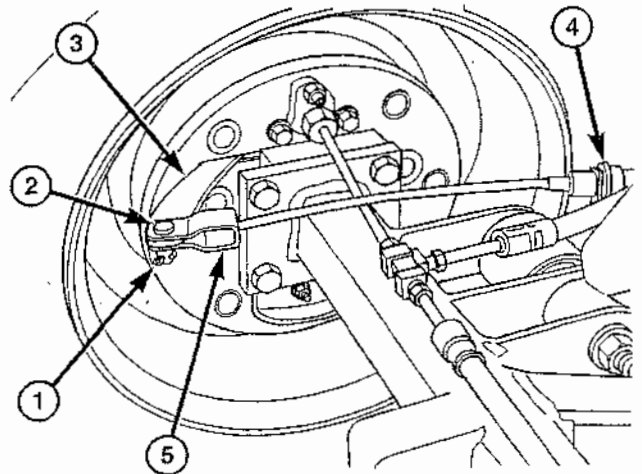

Figure 13 - Parking Brake Cable Attachment

1. Cotter pin
2. Clevis pin
3. Actuator lever
4. Cable mounting bracket
5. Cable end

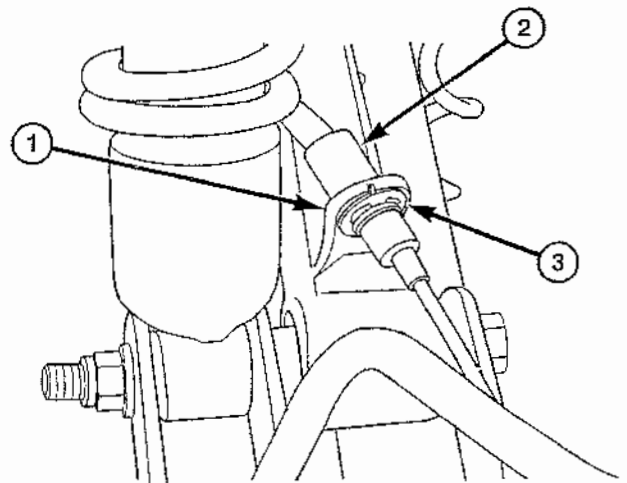

Figure 14 - Parking Brake Cable Mounting

1. Mounting bracket
2. Parking brake cable
3. Retaining ring

INSTALLATION

1. Install park brake cable into retainer on frame, attach with retaining rings.
2. Position cable end over park brake actuator lever on rear brake assembly. Insert clevis pin to attach, insert cotter pin in clevis to retain pin.
3. Install spat. See SPAT in BODY section.
4. Install rear shock mount cover. (See REAR SHOCK MOUNT COVER in BODY section.)
5. Insert park brake cables into the equalizer
6. Adjust tension on park brake cables. (See PARK BRAKE CABLE TENSION ADJUSTMENT below.)
7. Uncover battery terminals and switch master disconnect ON.
8. Install lower seat. (See BENCH SEAT in BODY section.)

TORQUE SPECIFICATIONS

DESCRIPTION	THREAD SIZE	Use Loctite® 242	INCH-POUNDS	FOOT-POUNDS
Brake, Parking – Cable Mount to Rear Suspension	1/2 x 13	NO	---	90

PARK BRAKE CABLE TENSION ADJUSTMENT

1. Chock wheels
2. Remove bench seat cushion. (See SEATS in BODY section.)
3. Release park brake.
4. Locate threaded adjusting rod/cable assembly at the end of the lever.
5. Using 1/2" open wrenches, back off rear nut to release forward adjusting nut.
6. Thread forward adjusting nut forward or backward as needed to adjust tension.
7. Tighten rear nut against adjusting nut to lock in place.
8. Apply park brake and test by attempting to roll vehicle forward by pushing it. If vehicle moves, repeat tension adjustment procedure.

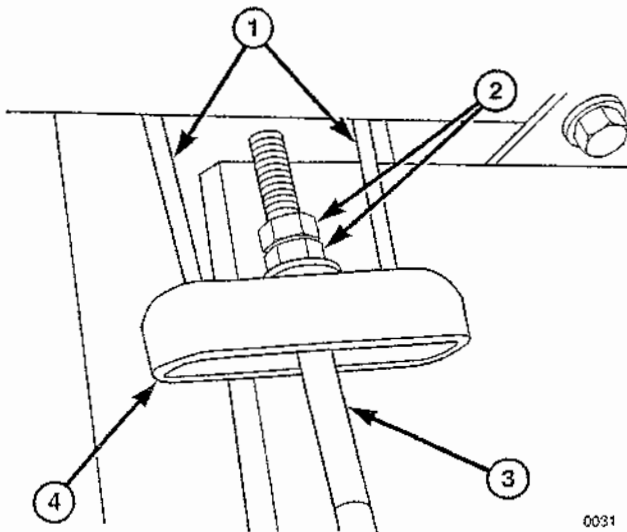

0031

Figure 15 - Park Brake Cable Tension Adjustment

1. Park brake cables (to rear wheels)
2. Jam nuts
3. Adjusting rod/cable assembly
4. Tension equalizer

CONTENTS

Electrical System	5-2
Power System	5-3
Drive System	5-3
Accelerator Pedal (Foot Pedal)	5-11
Battery	5-12
Charger	5-18
Motor Controller	5-19
DC-DC Converter	5-21
Main Contactor	5-22
Motor	5-23
Battery Discharge Indicator (BDI)	5-25
Accessory System	5-27
Accessory System Component Replacement	5-29
System Schematics	5-30
Head Light and Front Turn Signal Circuit	5-31
Horn and Wiper Circuit	5-32
Tail Light and Rear Turn Signal Circuit	5-33
Brake Light and Warning Circuit	5-34
Battery Charger Circuit	5-35
Main Contactor Circuit	5-36
Motor Circuit	5-37
Head Light Harness	5-38
Front Harness	5-39
Instrument Panel Harness	5-40
Main Harness	5-42
Power Harness	5-46
Tail Light Harness	5-47

ELECTRICAL

ELECTRICAL SYSTEM

Description

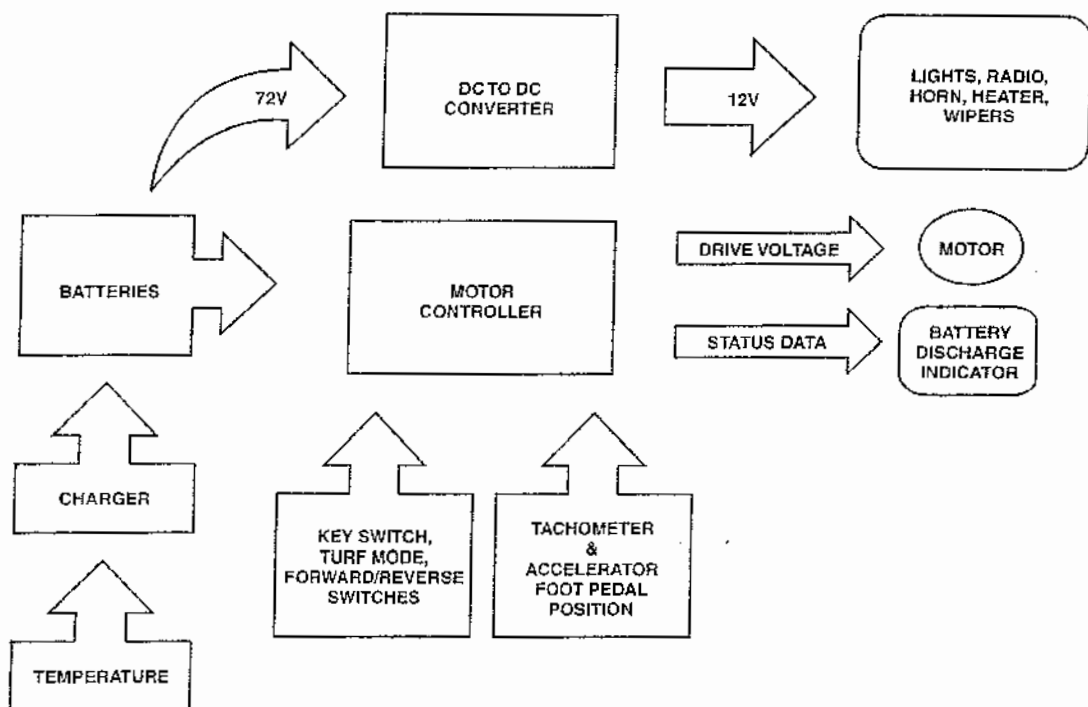

0115

Figure 1 - Electrical System Diagram

The electrical system of the GEM is shown in the block diagram above. For purposes of operational description, the system is divided into three groups - the Power System, the Drive System and, the Accessory System.

WARNING!

Always turn off the Master Disconnect Switch and allow a few minutes for the system to discharge before servicing the electrical system. Never wear loose jewelry, rings or watches. Always use insulated tools to prevent shorting.

NOTE: The Master Disconnect Switch is located under the bench seat (see figure 4). Turn switch counter-clockwise to turn off.

POWER SYSTEM

Description

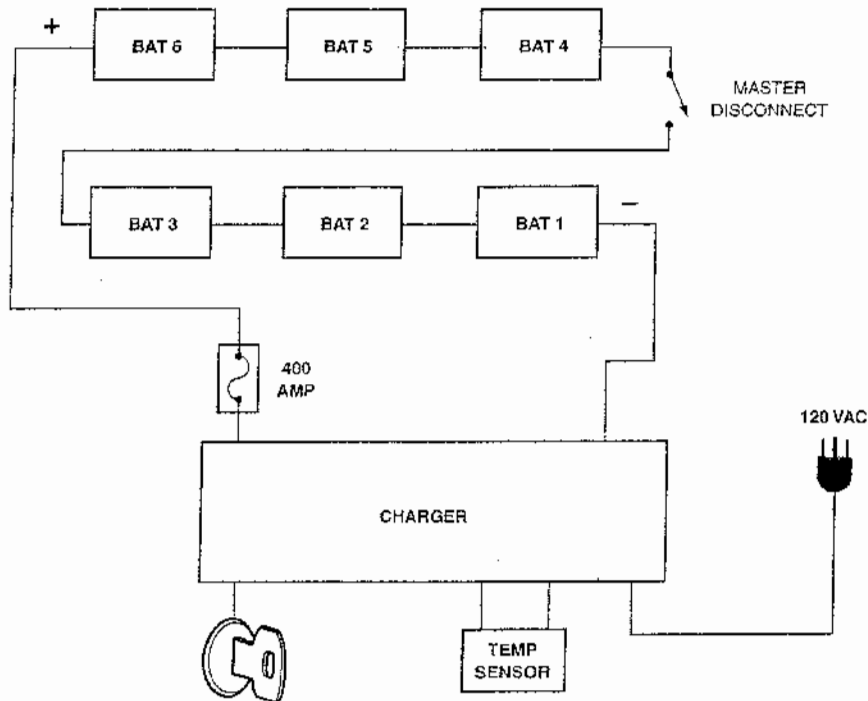

Figure 2 - Power System

The purpose of the Power System is to provide primary power for the Drive and Accessory Systems. The Power System consists of the batteries, battery charger, fuse, key switch, temperature sensor, and power harness (not shown in the block diagram). Six 12-volt series-wired lead-acid batteries provide a total power supply voltage of 72 volts.

Operation

The battery charger automatically recharges the battery to 100% charge when plugged into a standard 110-volt, 15-amp-breaker outlet. When the charger is active, logic in the Motor Controller prevents the vehicle from being operated. The battery charger monitors battery temperature by means of a temperature sensor. If the battery temperature reaches above 120 degrees, the charger will shut down.

Diagnosis and Testing

Diagnosis and testing of the power system is integrated with the Diagnosis and Testing of the Drive system.

DRIVE SYSTEM

Description

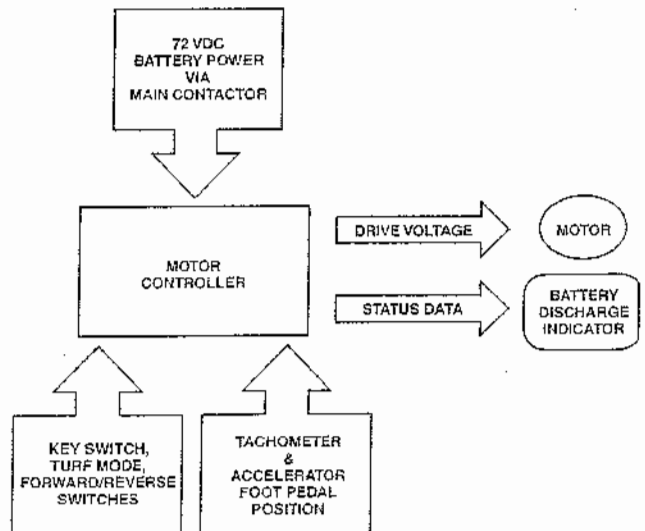

Figure 3 - Drive System

The Drive System consists of the Main Contactor, Motor Controller, DC Motor, Battery Discharge Indicator (or BDI), tachometer, accelerator foot pedal, direction switches, turf switch, main wiring harness and other associated wiring.

Operation

The Drive System is powered by the 72 VDC generated by the batteries. If the Main Contactor is closed, the Motor Controller provides drive voltage to the motor based on inputs from the turf mode switch, motor tachometer, and the accelerator foot pedal position. The forward and reverse switch determines vehicle direction. The variable speed, reversible, DC motor supplies mechanical drive power. Power and drive system operation is monitored by the Motor Controller; status information is displayed on the BDI.

The "Basic Operation" procedures described in the Owner's Manual must be followed for the Drive System to operate properly. If the Drive System does not operate, first verify the following steps have been completed:

- Main disconnect switch (see figure 5) is in the "ON" position (shown in the off position in the illustration),
- Batteries are charged, but the battery charger is not plugged in,
- Parking Brake (see figure 6), has been released,
- Key switch (see figure 7, item 11), is in the ON position,
- After turning the Key Switch to "On," the Vehicle Directional Switch (see figure 7, item 10), has been placed in either "Forward" or "Reverse".

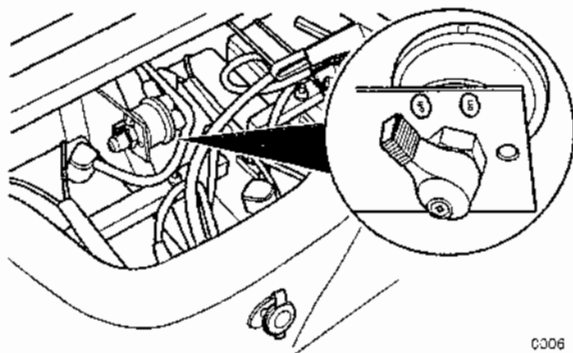

Figure 4 - Master Disconnect Switch

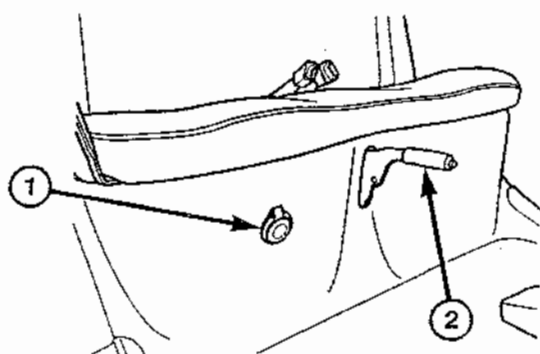

Figure 5 - Parking Brake

1. Charge Receptacle
2. Parking Brake Handle

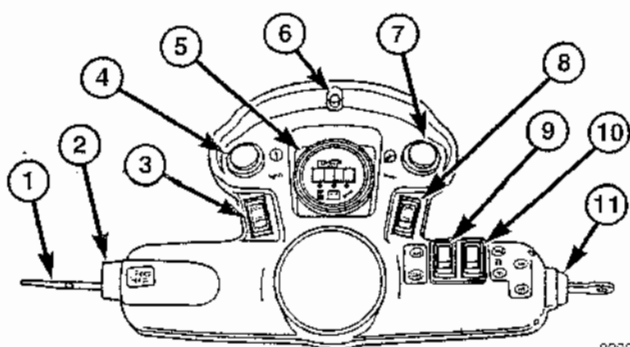

Figure 6 - Instrument Pod

1. Turn Signal Lever
2. Horn Button
3. Light Switch
4. L-Turn Signal/Brake Warning Light
5. Battery Discharge Indicator (BDI)
6. Charge Status Light
7. R-Turn Signal/Seat Belt Warning Light
8. Windshield Wiper Switch
9. Road/Turf Switch
10. Vehicle Direction Switch
11. Key Switch

Diagnosis and Testing

The purpose of this section is to aid in the isolation of problems with the Drive System and Power System. The primary means of troubleshooting the Drive and Power System is via error codes displayed on the Battery Discharge Indicator (see figure 6 - item 5). If system problems cannot be isolated by use of error codes, refer to the "Drive and Power System Troubleshooting Charts" in this section.

NOTE: The information provided in this section is a guide only. There are numerous variations in the skill level of personnel that service this vehicle. This manual cannot possibly accommodate all skill levels and provide advice for each. A basic understanding of electronics and troubleshooting techniques is required.

WARNING!

Whenever possible, service the vehicle with the Master Disconnect Switch turned off. If the Master Disconnect Switch is on, to measure voltage, use extreme caution. Dangerous voltage is present. Remove all jewelry such as rings, watches, or necklaces that could contact electrical connections and conduct electricity. Severe injury, burns, or even death could occur if caution is not used.

Drive and Power System Error Codes

The Motor Controller monitors the Drive System when the vehicle is powered up (key is in the ON position). The Motor Controller reports any problems detected by displaying error codes on the multi-purpose Battery Discharge Indicator located in the center of the instrument pod. Error Codes are explained in the table below.

Error Code	Fault Description	Corrective Action
NONE	Display on the Battery Discharge Indicator (BDI) is blank.	Insure the key switch is closed. If switch is closed, verify voltage is present between Motor Controller connector MH20 pin 2 and the controller negative terminal. (Refer to the Main Contactor Circuit Diagram.) Check for an open circuit or loose connection from the "Y" plug and the BDI. If voltage is present, and there are no loose connections, replace the BDI.
-02	Car was turned on while the direction switch was in the forward position.	Move the direction switch to neutral and then, select the desired direction.
-03	Car was turned on while the direction switch was in the reverse position.	Move the direction switch to neutral and then, select the desired direction.
-04	Emergency brake switch is open.	Verify that the emergency brake has been fully released. If problem persists, the emergency brake switch may be misadjusted or defective. Refer to the Main Contactor Circuit Diagram for troubleshooting the emergency brake circuit. Note: the diagram shows the brake switch when the brake is engaged.
-05	Start switch failed to close.	Start switch may be defective. Refer to the Motor Circuit Diagram for troubleshooting the start switch circuit.
-06	Accelerator pedal was pushed without a direction being selected.	Release the accelerator pedal, select a direction and then, push the accelerator pedal.
-08	Accelerator voltage input is too high on power up after initial key switch closure.	Refer to the Motor Circuit Diagram for roubleshooting the start switch circuit. The accelerator pedal input to the Motor Controller (MH20, pin 7) should be less than 0.9 VDC before depressing the pedal. If the voltage is greater than 0.9 VDC, the accelerator pedal may be misadjusted or defective.
-09	Both the forward and reverse switches are closed at the same time.	Refer to the Motor Circuit Diagram for troubleshooting the start switch circuit. There should be no input voltage present at Motor Controller connector MH20 pins 4 and 5 from the forward or reverse switches if the switch is in the neutral position. Voltage should only be present at 4 or 5, but not both when forward or reverse are selected.
-11	Accelerator pedal was pushed when the car was first turned on.	Release the accelerator pedal, select a direction and then, push the accelerator pedal. This error code may also be cause by a defective emergency brake microswitch.
-15	Low battery pack voltage (less than 70 VDC).	Charge the car (see Charger in this section for instructions on charging the battery).

Error Code	Fault Description	Corrective Action
-16	Battery pack voltage is greater than 86 VDC	Check the battery pack. Verify that the proper voltage is present (see Step 4 of the Drive System Troubleshooting Chart for instructions on checking battery voltage). If the voltage is over 86 VDC, try running the headlights for a little while to drain the battery charge. If the voltage is below 86 VDC, there is a problem with the sensing circuit in the Motor Controller.
-21	Problem with the accelerator pedal wiring.	See Accelerator Pedal - Diagnosis and Testing.
-23	Motor field current is too high when the start switch is closed and the reverse direction is selected.	Replace the Motor Controller.
-24	Motor field current is too high when the start switch is closed and the forward direction is selected.	Replace the Motor Controller.
-27	12 VDC Buss voltage is too low (less than 9.35 VDC).	Verify 12 VDC is present between Motor Controller connector MH20 pin 1 and the controller negative terminal when the system is under load, e.g. headlights are on. (Refer to the Main Contactor Circuit Diagram.) If voltage stays above 9.35 VDC under load, then replace the Motor Controller. If voltage drops below 9.35 VDC, check for loose connections. If no loose connections are found, the DC to DC converter may be defective.
-41	Open thermal protector or transistor over temperature.	Motor Controller is in thermal cut back; allow to cool and the status code should disappear. If problem persists after the Motor Controller has cooled, replace the Motor Controller.
-42	Motor armature offset voltage is too high.	Replace the Motor Controller.
-43	Motor armature offset voltage is too low.	Replace the Motor Controller.
-44	Armature transistor did not turn off properly.	Replace the Motor Controller.
-45	Armature transistor did not turn off properly.	Replace the Motor Controller.
-46	"Look Ahead" test for Motor Controller A2 voltage is less than 12.5% of battery voltage.	This status code will be displayed if the voltage at A2 is less than 12.5% of battery voltage and the current is greater than 52 amps when the controller is in the neutral state. This can be caused by a short circuit from motor armature to the frame. Test for a short by opening the main disconnect switch, and using an ohmmeter, measure between Motor Controller A2 and ground; there should be an open circuit (greater than 5000 ohms.) If there is a short, check the wiring, and remove the short. If there is not short, replace the Motor Controller.
-49	Motor field current is too low during the run mode.	This status code will be displayed if the current draw in the motor field is less than 1.3 amps and the armature current is greater than 100 amps for more than 1.27 seconds during the run mode. Check wiring between the Motor Controller and the motor field connections (F1 and F2). If the connections are good, replace the Motor Controller.
-51	Motor Controller is not getting 72 volts.	See the Drive System Troubleshooting Chart step 1.
-57	Motor Controller "motor current sensor" input is too low while running.	Replace the Motor Controller.
-76	Capacitor 1C voltage is too high during regenerative braking.	Replace the Motor Controller.

Drive and Power System Troubleshooting Charts

The Drive and Power System Troubleshooting Chart A should be used as a guide to isolate electrical problems with the batteries, Master Disconnect Switch, main contactor, and Motor Controller that are not covered by the fault codes. Drive and Power System Troubleshooting Chart B should be used to as a guide to isolate problems with the motor, motor magnets, tachometer, and BDI. For problems with light, horn, or wipers - refer to the Accessory System Troubleshooting Chart.

Drive and Power System Troubleshooting Chart A

Note

All DC voltage measurements should be taken with respect to Motor Controller B- or chassis ground.

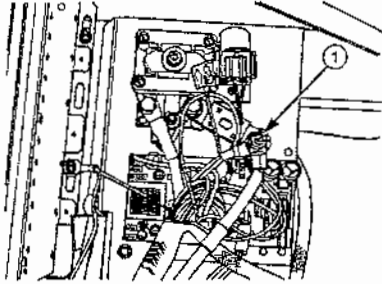
Step	Action	Yes	No
1	<p>Prior to turning the Key Switch to the On position, verify the following:</p> <ul style="list-style-type: none"> • Vehicle battery charger is not connected, • Main disconnect is turned on, • Vehicle Directional Switch is in the neutral position (neither Forward or Reverse), • Accelerator pedal is not depressed. <p>All conditions met?</p>	Proceed to Step 2	Make the necessary correction, and try operating the vehicle again.
2	<p>Turn the Key to the On position. You should see a - 04 on the Battery Discharge Indicator.</p> <p>When the parking brake is released, did you hear a "Clunk" sound from under the dash?</p>	Proceed to Step 3	Proceed to Step 4.
3	Are any error codes displayed on the Battery Discharge Indicator?	Use the "DRIVE SYSTEM ERROR CODES" to isolate the vehicle fault.	Proceed to Step 4.
4	<p>Remove upper and lower dash and locate the Main Contactor and Battery Fuse. Measure the voltage at the fuse connection (large black wire marked FUSE).</p>  <p>Figure 7 - Battery Fuse Connection</p> <p>1. Measuring point</p> <p>Is the voltage approximately 72 VDC?</p>	Proceed to step 5	<p>1. If a voltage is present, but less than 70 VDC, charge the batteries.</p> <p>2. If no voltage is present use the "Main Contactor" diagram and a voltmeter to check all battery connections and main disconnect switch.</p>
5	<p>Verify the Battery Fuse is not open by measuring the voltage at the fuse connection on the Main Contactor. The voltage should be the same (greater than 70 VDC) as the voltage measured in step 4.</p> <p>Is the Battery Fuse okay?</p>	Proceed to Step 6	Replace the fuse. If the fuse opens again, contact the GEM Service Department.

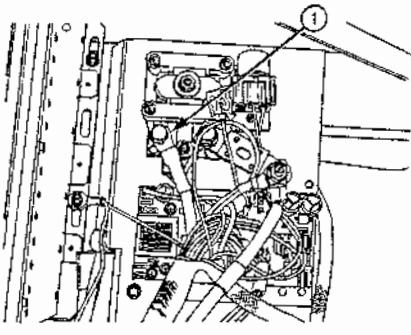
Step	Action	Yes	No
6	<p>Measure the voltage on the output side of the contactor.</p>  <p>Figure 8 - Main Contactor</p> <p>1. Measuring point</p> <p>Is the voltage approximately 72 VDC?</p>	<p>Check the voltage on the B+ input of the Motor Controller. If the voltage is approximately 72 VDC, Replace the Controller.</p> <p>If the voltage is 0, or significantly less than the voltage on the contactor, check the wire and the Motor Controller.</p> <p>Note: Loose fuse, contactor, Motor Controller B+ and B- connections can lead to overheating and damage to these circuits.</p>	Proceed to Step 7
7	<p>Turn the key on, drop the brake and measure the voltage on the Red/White wire connected to the contactor coil.</p> <p>Is the voltage approximately 72 VDC?</p>	Proceed to Step 8	Proceed to <u>Step 11</u> .
8	<p>Measure the voltage on the Black wire connected to the contactor coil. Turn the Key Switch from On to Off to On.</p> <p>Does the voltage stay a constant approximately 72</p>	Proceed to Step 9	Replace the contactor if the voltage is on the black wire changed from 0 to 72 VDC and back to 0 when the key was operated, and the contactor did not operate.
9	<p>Steps 9a through 9c will verify critical inputs to the Motor Controller. Each must be present before the Motor Controller will close the Main Contactor. Are all critical inputs good?</p>	Replace Motor Controller.	Troubleshoot circuit(s) suggested in step 9a through 9c.
9a	<p>Measure the voltage at Pin 1 of connector MH20 (23 pin connector on the top of the Motor Controller)?</p> <p>Is the voltage approximately 72 VDC?</p>	Proceed to Step 9b	Use the "Main Contactor" diagram to determine where the constant 72 VDC to the Controller has been lost.
9b	<p>Measure the voltage at Pin 2 of connector MH20 with the Key Switch in the On position?</p> <p>Is the voltage approximately 72 VDC?</p>	Proceed to Step 9c	Proceed to Step 9
9c	<p>Turn off the Main Disconnect Switch. Use an ohmmeter, measure the resistance at Pin 13 of connector MH20 to ground with the parking brake released (down).</p> <p>Is the resistance approximately 0 ohms?</p>	All critical inputs (for contactor operation) are good.	Check the parking brake switch, and wiring to the parking brake switch. See "Main Contactor Circuit" diagram.
10	<p>Turn off the Main Disconnect Switch and the Key Switch to On. Use an ohmmeter, measure the resistance at J2 Pin 6 of the PWB to ground.</p> <p>Is the resistance approximately 0 ohms?</p>	Replace the PWB.	Check the Key switch ground circuit through the Battery Charger. See the "Main Contactor Circuit" diagram.
11	<p>Measure the voltage on pin 11 of MH5 (16 pin connector on the PWB). Is the voltage approximately 72 VDC?</p>	Check wiring from main contactor to PWB. See the Main Contactor Circuit diagram.	Replace PWB.

Drive and Power System Troubleshooting Chart B

Symptom	Problem Description	Diagnostic Steps	Corrective Action
1	BDI does not show MPH indications when the car is moving.	Check tachometer for loose connections.	Replace motor tachometer
2	BDI does not show MPH indications when the car is moving, and tachometer has been replaced.		Replace motor magnets
3	Vehicle operated properly, but there are no status indication on the BDI	Verify connections between Motor Controller and BDI.	If there are no loose connections found, replace the BDI.
4	Battery charger will not charge battery	Verify the voltage to battery charger (110 VAC).	If voltage was not present, connect AC power, and try charging the batteries again. If they will not charge, go to step 5.
5	Battery charger will not charge battery, and voltage to battery charger (110 VAC) has been verified.	Disconnect the temperature sensor, and try charging the batteries again.	If the batteries charge after the temperature sensor is disconnected, replace the temperature sensor. If batteries still do not charge, go to step 6
6	Battery charger will not charge battery, voltage to battery charger (110 VAC) has been verified, and temperature sensor has been verified in step 5.	Verify voltage of each battery is greater than 10.5 VDC.	If any battery has an output voltage less than 10.5 VDC, turn off the MDS, and charge each battery with an offline battery charger for 1 hour. Then turn the MDS back on, and plug extension cord into the vehicle.

ACCELERATOR PEDAL (FOOT PEDAL)

Description

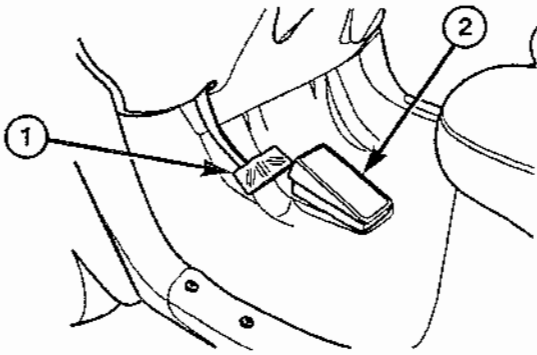

0004

Figure 9 - Foot Controls

1. Foot Brake Pedal
2. Accelerator Pedal

The "Accelerator Pedal" (see figure 9 - item 2), is located on the floor, close to the center of the vehicle and is used to control vehicle speed.

Operation

Pressing down on the pedal will increase speed. Letting up on the pedal will reduce power to the electric motor and vehicle speed will slowly decrease.

Diagnosis and Testing

The accelerator pedal module consists has two electrical components - the accelerator potentiometer and the start switch. Testing for accelerator potentiometer and the start switch are described separately below. It may be helpful to reference the Motor Circuit electrical diagram while testing these components.

Accelerator Potentiometer Testing

- a) Remove the upper dash and lower dash as described in Body and Panels Accessories.
- b) Disconnect 23-pin connector MH20 located on the top of the motor controller.
- c) Using an ohmmeter, measure the resistance between pin 9 and pin 7. When the accelerator pedal is in the up position, the ohmmeter should read approximately zero resistance (ohms). Push the accelerator pedal down; the resistance between pins 9 and 7 should gradually increase. When the accelerator pedal is completely down, the resistance

should reach a maximum of approximately 5000 ohms. If the resistance does not vary as described, replace the accelerator pedal. If the resistance is a constant very low resistance (possible short circuit) or constant high resistance (open circuit), there could be a problem with the wiring harness between the motor controller and the accelerator pedal module.

- d) Using an ohmmeter, measure the resistance between pin 9 and pin 8. The resistance between these two pins should remain approximately 5000 ohms regardless of the position of the accelerator pedal. If the resistance is very high, there is probably a broken wire between the motor controller connector and accelerator pedal.

Start Switch Testing

- a) Remove the upper dash and lower dash as described in Body and Panels Accessories. b) Disconnect 23-pin connector MH20 located on the top of the motor controller. Disconnect 16-pin connector MH5 from J2 of the Printed Wiring Board. c) Using an ohmmeter, measure the resistance between pin 3 of MH20 and pin 9 of MH5. With the accelerator pedal up, the circuit should be open (high resistance). With the accelerator pedal depressed, the resistance should be zero ohms (start switch is closed). If the resistance does not vary as described, replace the accelerator pedal.

Removal

1. Remove upper dash as described in Body Panels and Accessories.
2. Unplug foot pedal from wire harness.
3. Locate silver pushpins (spring loaded) on foot pedal cover sides (see figure 11 - item 1)
4. Using small screwdriver, or similar tool, push one of the pins in and slide the cover out of position. Repeat for other side.
5. Lift off cover.
6. Remove two Tek screws with socket and wrench. (see figure 12 - item 1)

Installation

1. Place the pedal housing back in its floor position and replace the two Tek screws.
2. Make sure the lift spring (see figure 12 - item 2) is properly seated in place before proceeding with step 3.
3. With the pushpins held in, slide the pedal cover into position over the housing until the pushpins snap into place.

4. Reattach the foot pedal cable connector.
5. Replace upper dash as described in Body Panels and Accessories.

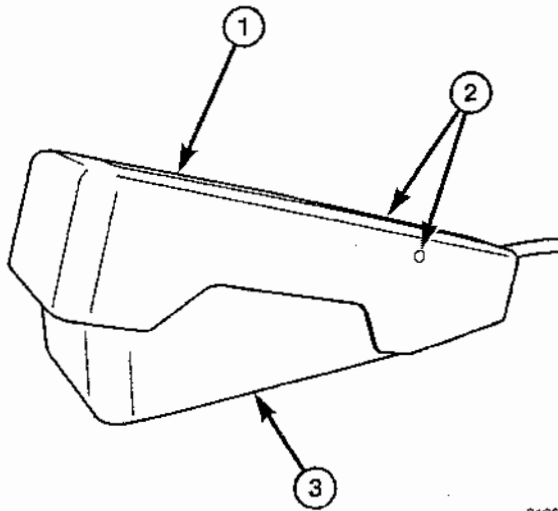

Figure 10 - Accelerator Pedal Assembly

1. Cover
2. Pushpins
3. Housing

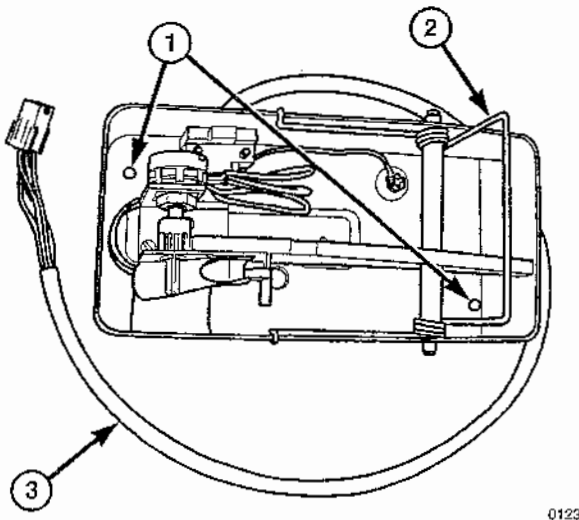

Figure 11 - Pedal Housing, Cover Removed

1. Tek screw locations
2. Lift spring
3. Cable

BATTERY

Description

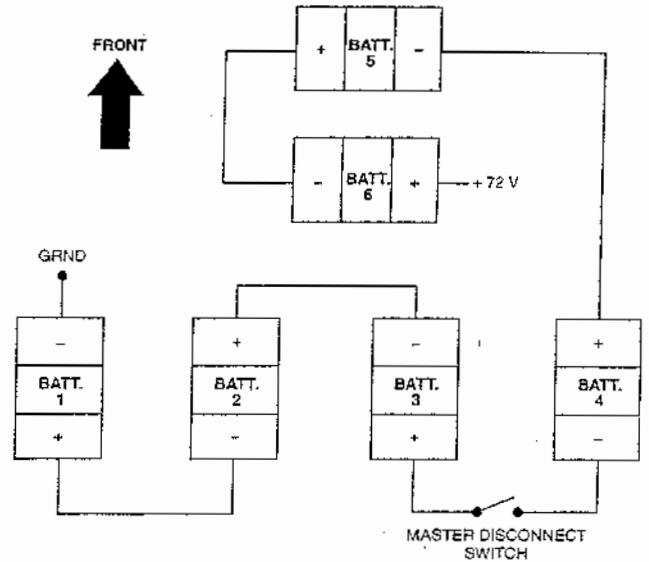

Figure 12 - Battery Layout

Six 12-volt lead acid, batteries, supply 72-volt power for the vehicle. Two are located under the front hood. Four are located under the front cushion on two-passenger models, and under the rear seat cushion on four-passenger models.

The batteries supplied with the GEM electric vehicle are Deep Cycle batteries. They are designed to handle discharges down to 20-30% of their rated capacity without doing any internal damage. Since the batteries in the electric vehicle must supply 100% of the energy required for operation, they are subject to deep discharges and then must be recharged to restore their capacity. In comparison, the standard automotive battery is known as a "starting, lighting, and ignition" (SLI) battery. It is designed to supply a very high cranking current for a brief period and then maintains the accessory loads on the car.

NOTE: Due to the different operating characteristics of the two types of batteries, automotive type batteries should never be substituted in place of a deep cycle battery.

Operation

The GEM vehicle has a battery control and recharge system especially designed for electric vehicle usage. The charging system is designed to maximize the battery pack life while recharging the pack, in the shortest time,

with available household current (110-volt, 15 amp, A/C outlet). The following guidelines will insure that you get the maximum battery life and performance out of your GEM electric vehicle.

- New batteries will not deliver their full capabilities until they have been discharged and recharged 20 to 50 times. Batteries should be fully charged before first use of new vehicle, before releasing vehicle for daily use.
- When recharging, it is preferable to have the battery pack at close to room temperature. Do not have in direct sunlight, on hot pavement or in excess heat of 110f or higher.
- Batteries should be charged after each period of use.
- Lead Acid batteries do not develop a memory and need not fully discharge before recharging.

WARNING!

Always wear safety glasses or approved eye protection when servicing the vehicle. Wear a full-face shield when working with batteries. Always use insulated tools when working around batteries or electrical connectors.

WARNING!

Battery fluid is a corrosive acid solution and can burn or even blind you. Don't allow battery fluid to contact eyes, skin or clothing. If acid splashes in eyes or on the skin, flush the area immediately with large amounts of water. Battery gas is flammable and explosive. Keep flame or sparks away from the battery or any other booster source with an output greater than 12-volts. Don't allow cable clamps to touch each other. Battery posts, terminals and related accessories contain lead and lead compounds. Wash hands after handling.

CAUTION!

It is essential when replacing the cables on the battery that the positive cable is attached to the positive post and the negative cable is attached to the negative post. Battery posts are marked positive (+) and negative (-) and identified on the battery case. Cable clamps should be tight on the terminal posts and free of corrosion.

Removal and Disposal

1. Disconnect all cables from all six batteries noting connections and locations.
2. Remove hold downs, or cut battery straps (large wire tie) and remove from each battery.
3. Lift batteries out using proper lifting procedures or battery lifting tools.
4. Reverse procedure to reinstall. Tighten with battery strap tool, if applicable.
5. Use ecologically sound procedures to dispose of batteries.

Battery Safety

Improper use and care of batteries can result in serious personal injury or property damage. Always observe the following safety precautions:

- The Battery produces explosive gases. Keep sparks, flame or cigarettes away. Always wear safety goggles or face shield when working near battery.
- The battery contains toxic materials. Do not damage battery case. If case is broken or damaged, avoid contact with battery contents. Neutralize acid spills with baking soda and water solution. Properly dispose of a damaged or worn-out battery. Check with local authorities for proper disposal methods.
- Do not short circuit battery. Severe fumes and fire can result.

WARNING!

Explosive Gases: Cigarettes, flames or sparks could cause battery to explode. Always shield eyes and face from battery. Do not charge or use booster cables or adjust post connections without proper instructions or training. Keep vent caps tight and level.

WARNING!

POISON / ACID Causes severe burns. Batteries contain sulfuric acid. Avoid contact with skin, eyes or clothing. In the event of accident flush with water and call a Physician immediately.

First Aid Treatments

- External Contact: Flush immediately with plenty of water.
- Internal: Call a Physician immediately. Then drink large quantities of water or milk: Follow with milk of magnesia, beaten egg or vegetable oil.
- Eye Contact: Flush with water for 15 minutes. Get prompt medical attention. Inspection There are many tools that may help in properly caring for and maintaining batteries. Below is a list of basic items that GEM recommends for this task:

WARNING!

Always wear protective clothing, gloves, and goggles when handling batteries and electrolyte.

WARNING!

DO NOT SMOKE NEAR BATTERIES

Recommended Equipment

- Wrench
- Distilled Water
- Voltmeter
- Hydrometer
- Discharge Machine
- Post Cleaner
- Baking Soda
- Vaseline
- Goggles & Gloves

Batteries should be carefully inspected on a regular basis in order to detect and correct potential problems before they can do harm. It is a great idea to start this routine when the batteries are first received.

1. Examine the outside appearance of the battery.
 - Look for cracks in the container
 - The top of the battery, the posts, & connections should be clean, free of dirt, fluids, and corrosion. If batteries are dirty, refer to the Cleaning section for the proper cleaning procedure.
 - Repair or replace any damaged batteries.
2. Fluids on or around the battery may be an indication that electrolyte is spilling, leaching, or leaking out.
 - Leaking batteries must be repaired or replaced.
3. Check all battery cables and their connections.
 - Look closely for loose or damaged parts.
 - Battery cables should be intact; broken or frayed cables can be extremely hazardous.
 - Replace any cable that looks suspicious.
4. Tighten all wiring connections to the proper specification (see below). Make certain there is good contact with the terminals.

Proper Torque Values for Connection Hardware

Flooded

70 to 95 in-lbs.

CAUTION!

Do not over-tighten terminals. Doing so can result in post breakage, post meltdown, and fire.

Testing

Visual inspection alone is not sufficient to determine the overall health of the battery. Both open circuit voltage and specific gravity readings can give a good indication of the battery's charge level, age, and health. Routine voltage and gravity checks will not only show the state of charge but also help spot signs of improper care, such as undercharging and over-watering, and possibly even locate a bad or weak battery. The following steps outline how to properly perform routine voltage and specific gravity testing on batteries.

NOTE: "Temperature" in the following section refers to electrolyte temperature not ambient temperature.

Specific Gravity Test For Flooded (water based) Batteries

1. Do not add water at this time.
2. Fill and drain the hydrometer 2 to 4 times before pulling out a sample.
3. There should be enough sample electrolyte in the hydrometer to completely support the float. The float should be floating freely and not touching the sides of the cylinder.
4. Take a reading, record it, and return the electrolyte back to the cell.
5. To check another cell, repeat the 3 steps above.
6. Check all cells in the battery.
7. Replace the vent caps and wipe off any electrolyte that might have been spilled.
8. Correct the readings to 80°F:
 - Add .004 to readings for every 10°F above 80°F.
 - Subtract .004 for every 10°F below 80°F.
9. Compare the readings.
10. Check the state of charge using **Table 1**.

The readings should be within the factory specification of $1.277 \pm .007$. If not, follow the steps below.

1. Check and record voltage level(s)
2. Put battery(s) on a complete charge.
3. Take specific gravity readings again.

If any specific gravity reading is still not within the factory specification, follow the steps below.

1. Check voltage level(s).
2. Perform equalization charge. Refer to the **Equalizing** section for the proper procedure.
3. Take specific gravity readings again.

If any specific gravity reading is still not within the factory specification of $1.277 \pm .007$ then one or more of the following conditions may exist:

1. The battery is old and approaching end of life.
2. The battery was left in a state of discharge too long.
3. Electrolyte was lost due to spillage or over-flow.
4. A weak or bad cell is developing.
5. Battery was watered excessively previous to testing

NOTE: Batteries in conditions 1-4 should be taken to a specialist for further evaluation or retired from service.

Open-Circuit Voltage Test

For accurate voltage readings batteries must remain idle (no charging, no discharging) for at least 6 hrs., preferably 24 hrs.

1. Disconnect all loads from the batteries.
2. Measure the voltage using a DC voltmeter.
3. Check the state of charge with **Table 1**.
4. Charge the battery if it registers 0% to 70% charged.

If battery registers below the **Table 1** values, the following conditions may exist:

1. The battery was left in a state of discharge too long.
2. The battery has a bad cell.

Batteries in these conditions should be taken to a specialist for further evaluation or retired from service.

Percentage of Charge	Specific Gravity Corrected to 80° F	Open-Circuit Voltage
100	1.277	12.73
90	1.258	12.62
80	1.238	12.50
70	1.217	12.37
60	1.195	12.24
50	1.172	12.10
40	1.148	11.96
30	1.124	11.81
20	1.098	11.66
10	1.073	11.51

Table 1 - State of Charge as related to Specific Gravity and Open-Circuit Voltage

Discharge (Load) Test

There are two reasons for using a discharge unit on a battery set:

1. To determine battery capacity.
2. To find defective cells or batteries in a battery set.

Battery energy is measured in minutes obtained upon discharging a fully charged battery set with a known resistive load at a controlled temperature until a shut-off voltage of 10.5 volts per battery is reached.

NOTE: The following procedure is written specifically for a 36 volt, 75-amp discharge unit, which automatically shuts off at a specified voltage. Follow all manufacturers instructions when operating discharge units. Two units will be needed to discharge the GEM 72 volt battery set simultaneously.

Discharge Procedure

1. Fully charge the batteries.
2. Turn the Master Disconnect switch to OFF. 3. Connect the discharge unit(s) to the battery set as shown in (Fig. # 1)
4. After all the safety procedures specified by the manufacturer have been followed, start the unit.
5. When unit shuts off, record the discharge time.

WARNING!

If the battery leads are reversed, the discharge machine will not run. However, an electrical arc could occur and result in an explosion.

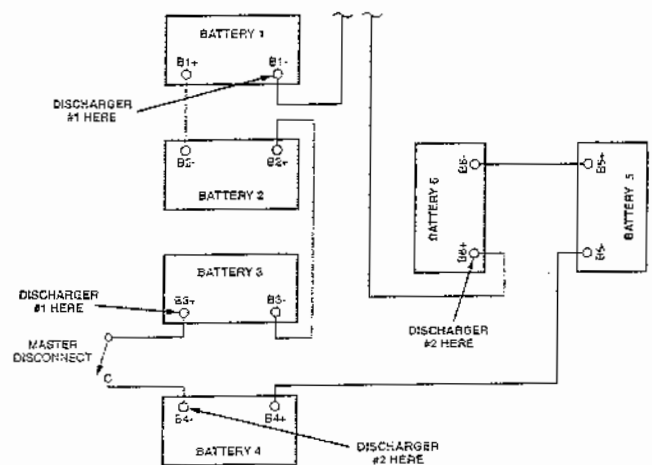

Figure 13 - Discharge connection locations

Calculating Battery Capacity

Battery capacity is expressed by the percentage of time until shut-off voltage is reached. In order to determine the accurate capacity of a battery set, the manufacturer's rating at a 75-amp discharge rate must be known. Also, this value is only accurate for mature batteries, ones that have 50-70 cycles on them.

EXAMPLE:

- Manufacturer's rating - 56 minutes @ 75 amp
- Discharger shuts down after 42 minutes
- Battery capacity is $42/56 * 100\% = 75.0\%$

If capacity is below 50%, batteries may be nearing the end of their life and need to be replaced.

Testing For Defective Cells

During a discharge, all cells in a battery set should discharge at the same rate. If one or more of the cells decrease at a faster rate, the total discharge time may indicate an unacceptable result. Therefore, the individual batteries must be compared against the others to see if one or more of the units need to be replaced.

1. After discharge unit has shut down from previous test, start unit again.
2. Take voltage measurements across each battery while the discharger is running.
3. If one or two of the batteries differ in voltage from the other(s) by more than 0.5 volts, replace the ones with low voltages.
4. Turn discharge unit off.

EXAMPLE:

- Battery 1: 11.0 volts
- Battery 2: 10.2 volts
- Battery 3: 10.3 volts
- Replace Batteries 2 and 3.

NOTE: Unless the batteries are relatively new (less than 6 months old), replace with batteries of similar age and usage.

NOTE: Be sure to charge batteries after completing the discharge test. Leaving batteries in a discharged state causes sulfation to occur which will reduce the life of the batteries.

Watering

Note: This applies to flooded batteries only. "Flooded" means water base batteries.

Flooded batteries need water. More importantly, watering must be done at the right time and in the right amount or else the battery's performance and longevity suffers. Water should always be added after fully charging the battery. Prior to charging, there should be enough electrolyte to cover the plates. If the battery has been discharged (partially or fully), the electrolyte level should also be above the plates. Keeping the electrolyte at the correct level after a full charge will prevent having to worry about the level at other state of charge. Depending on the local climate, charging methods, application, etc. GEM recommends that batteries be checked once a month until you get a feel for how "thirsty" your batteries are.

WARNING!

The electrolyte is a solution of acid and water so skin contact should be avoided.

Important things to remember:

1. Do not let the plates get exposed to air. This will damage (corrode) the plates.
2. The electrolyte level should not be up inside the fill well. This may cause the battery to over-flow electrolyte during charging, resulting in a loss of capacity as well as causing a corrosive mess.
3. Do not use water with a high mineral content. Use distilled or de-ionized water only.

Step by step watering procedure:

1. Remove the vent caps and look inside the fill wells.
2. Check electrolyte level; the minimum level is at the top of the plates.
3. If necessary add just enough water to cover the plates at this time.
4. Replace and tighten all vent caps.
5. Put the battery on a complete charge before adding any additional water (refer to the **Charging** section).
6. Once charging is completed, remove the vent caps and look inside the fill wells.
7. Add water until the electrolyte level is about 1/8" below the bottom of the fill well.
8. Clean, replace, and tighten all vent caps.

Cleaning

After time batteries attract dust, dirt, and grime. In addition, electrolyte expelled from the battery vent caps due to over-watering and/or overcharging can form a conductive path that will cause the batteries to discharge. Keeping them clean will help one spot trouble signs if they appear and avoid problems associated with grime.

CAUTION!

When cleaning, do not allow any cleaning solution, or other foreign matter to get inside the battery.

1. Check that all vent caps are tightly in place.
2. Clean the battery top with a cloth or brush and a solution of baking soda and water.
3. Rinse with water and dry with a clean cloth.
4. Clean battery terminals and the inside of cable clamps using a post and clamp cleaner.
5. Clean terminals will have a bright metallic shine.
6. Reconnect the clamps to the terminals and thinly coat them with petroleum jelly (Vaseline) to prevent corrosion.
7. Keep the area around the battery clean and dry.

CAUTION!

Never hose the batteries down with tap water. The sulfuric acid content of the electrolyte will spread to other surfaces and cause corrosive damage.

WARNING!

Never add acid to a battery.

Storage

Periods of inactivity can be extremely harmful to lead-acid batteries. When placing a battery into storage, follow the recommendations below to insure that the battery remains healthy and ready for use.

NOTE: Storing, charging or operating batteries on concrete is perfectly OK.

Avoid temperature extremes when choosing a storage area:

1. Avoid locations where freezing temperature is expected. Keeping battery at a high state of charge will also prevent freezing. Freezing results in irreparable damage to battery's plates and container.

2. Avoid direct exposure to heat sources, such as radiators or space heaters. Temperatures above 80° F accelerate the battery's self-discharge characteristics

Step-by-step storage procedure:

1. Completely charge the battery before storing.
2. Remove bench seat cushion (rear bench seat cushion for 4 passenger vehicles) to access the Master Disconnect switch. Switch master disconnect off.
3. Store the vehicle in a cool, dry location, protected from the elements.
4. During storage, monitor the specific gravity or voltage. Batteries in storage should be given a boost charge when they show a 70% charge or less. See Table 1.
5. Completely charge the battery before reactivating.
6. For optimum performance, equalize the batteries before putting them back into service. Refer to the **Equalizing** section for this procedure.

Charging

WARNING!

Charge batteries only in well-ventilated area. Keep sparks or flames away from a charging battery.

1. Become familiar with the charger and follow the instructions. (See charger in the electrical section.)
2. Batteries should be charged after each period of use.
3. Lead-acid batteries do not develop a memory and need not be fully discharged before re-charging.
4. Check electrolyte level (refer to the Watering section).
5. Tighten all vent caps before charging.
6. Do not undercharge the batteries. Under-charging causes stratification.
7. Do not charge a frozen battery.
8. Avoid charging at temperatures above 120°F.

Equalizing

NOTE: Equalization applies to flooded (water based) batteries only.

Equalizing is an overcharge performed on flooded lead-acid batteries after they have been fully charged. It reverses the buildup of negative chemical effects like stratification, a condition where acid concentration is greater at the bottom of the battery than at the top. Equalizing also helps to remove sulfate crystals that

might have built up on the plates. If left unchecked, this condition, called sulfation, will reduce the overall capacity of the battery.

It is often recommended that batteries be equalized periodically, from once a month to once or twice per year. However, equalizing is recommended when low or wide ranging specific gravity ($\pm .015$) is detected after fully charging a battery. The on-board charger in your GEM vehicle can perform a short-term equalization charge. After a full charge, unplug the extension cord, wait 20 seconds, and plug back in.

CHARGER

Description

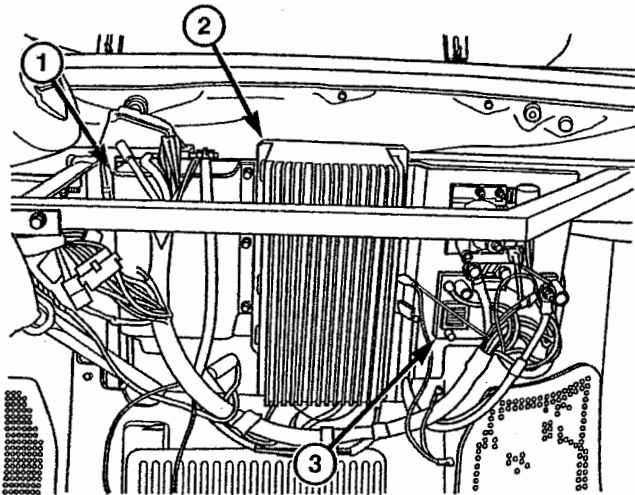

0110

Figure 14 - Charger Location (Schott Charger shown)

1. Motor Controller
2. Battery Charger
3. Printed Wiring Board (PWB)

The "Battery Charger" is located under the dashboard and is an integral part of the vehicle (see figure 13).

The "Battery Charge Receptacle" (see figure 5), is located on the front tub, below the passenger seat on the two-passenger model, and on the rear tub of the four-passenger model. It accepts a standard 3 wire (grounded) extension cord and should not exceed the following:

- 12 gauge wire 50 feet in length
- 14 gauge wire 25 feet in length

Operation

Insert the proper extension cord into the battery charger receptacle and, into a 110-volt A/C, 15amp-breaker outlet. (GFI is recommended)

When the battery charger is active, the control circuit prevents operation of the vehicle and the BDI is disabled. The indicator light will inform you of the battery charge status.

Schott Charger

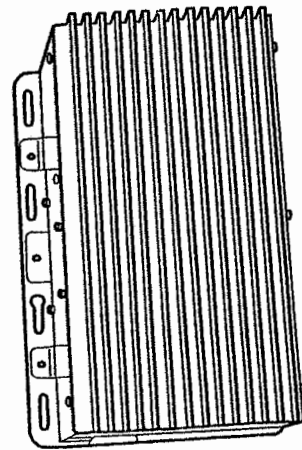

0120

Figure 15 - Schott Charger

The indicator light on the BDI will blink rapidly during initial charging, when the battery charge is low. The indicator light will blink slowly as the battery nears the end of its charge cycle, and will remain lit when the battery becomes fully charged.

Zivan Charger

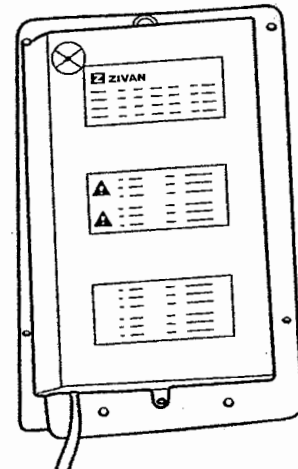

0121

Figure 16 - Zivan Charger

On vehicles equipped with a Zivan charger, light-emitting diodes on the BDI will operate as follows to indicate charging status.

- **BLINKING RED** shows that the battery is in the initial charge phase.
- **RED LED** shows that the battery charger has reached 80% of charge.
- **YELLOW LED** shows that the battery charger has reached 90% of charge.
- **GREEN LED** shows that the battery has reached 100% of charge.

To determine the battery charge level, unplug the charger and turn the power key on. If the BDI reads between 25% and 90%, the battery pack should be recharged. If the BDI reads below 25% the battery pack should be put on charge as soon as possible. A full recharge cycle (BDI indicating near 0%) can take up to 10 hours. Most recharge cycles will be much shorter.

NOTE: Recharge cycles are encouraged anytime the BDI reads below 90%.

CAUTION!

With an intermittent audible alarm and the Charge Status Indicator flashing, means that an alarm situation has occurred and there is a problem with the charger.

NOTE: After charging, the BDI will read slightly high until the batteries have time to settle, which can be approximately an hour. Driving the vehicle for over a minute and then cycling the power key off and back on can obtain a more accurate reading.

CAUTION!

- Fully charge batteries before extended periods of use.
- In hot climates, battery self discharge will increase.
- Batteries will freeze if not properly charged.

Replacement

1. Turn off the Master Disconnect Switch.
2. Remove upper and lower dash.
3. Disconnect electrical connections, noting connection and orientation.
4. Remove four mounting bolts from the flange of the charger. **NOTE:** The E580 has three bolts with

rubber shock mounts between the flange and the frame.

5. Reverse procedure to reinstall.

Charging When Below Minimum Voltage

The on-board charger has a safety feature, which does not allow it to turn on if the pack voltage is below 68.3 volts. If the battery pack goes below this level an alternative charging procedure must followed:

1. Turn off Master Disconnect switch under the seat.
2. Using an automotive type 12V charger, charge each battery individually. Set the charger on a medium current level (10-30 Amps). Allow enough charge time so the voltage on each battery is at least 10.5 volts (30 minutes to 1 hour per battery).
3. After all batteries have been charged, remove charger and turn on the Master Disconnect Switch. Measure pack voltage according to above diagrams. If the pack voltage is above the low voltage threshold, plug in the on-board charger. Allow the on-board charger to run it's complete cycle.

MOTOR CONTROLLER

Description

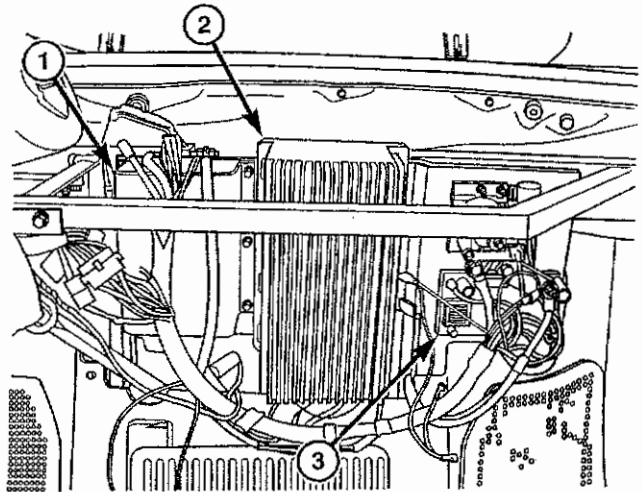

0110

Figure 17 - Charger Location (Schott Charger shown)

1. Motor Controller
2. Battery Charger
3. Printed Wiring Board (PWB) The motor controller, shown above, is located under the front dash to the left of the battery charger

The motor controller is the "brains" of the GEM vehicle. Based on inputs from the accelerator pedal, directional

switch, and turf mode switch, the controller converts battery power into the appropriate drive power for the vehicle's electric motor. The controller also generates drive system status information that is displayed on the Battery Discharge Indicator.

Operation

The controller functions automatically when the Master Disconnect is in the "ON" position. There are no other direct operator interactions with the motor controller module. "Operation" of the motor controller is accomplished by actuation of the devices such as the accelerator pedal, turf and directional switches.

Diagnosis and Testing

The motor controller function is critical to every aspect of the drive system. If a fault occurs with the motor con-

troller, you should see an error code on the Battery Discharge Indicator. Use the Drive and Power System Error Codes section starting on page 5-6 ELECTRICAL to help in isolating the fault.

Replacement

1. Turn off the Master Disconnect Switch.
2. Remove upper and lower dash.
3. Disconnect all cables and connectors, noting connection location and wire orientation.
4. Remove bolts holding controller to fire wall.

Installation

1. Reverse procedure to reinstall.

PRINTED WIRE BOARD

Description

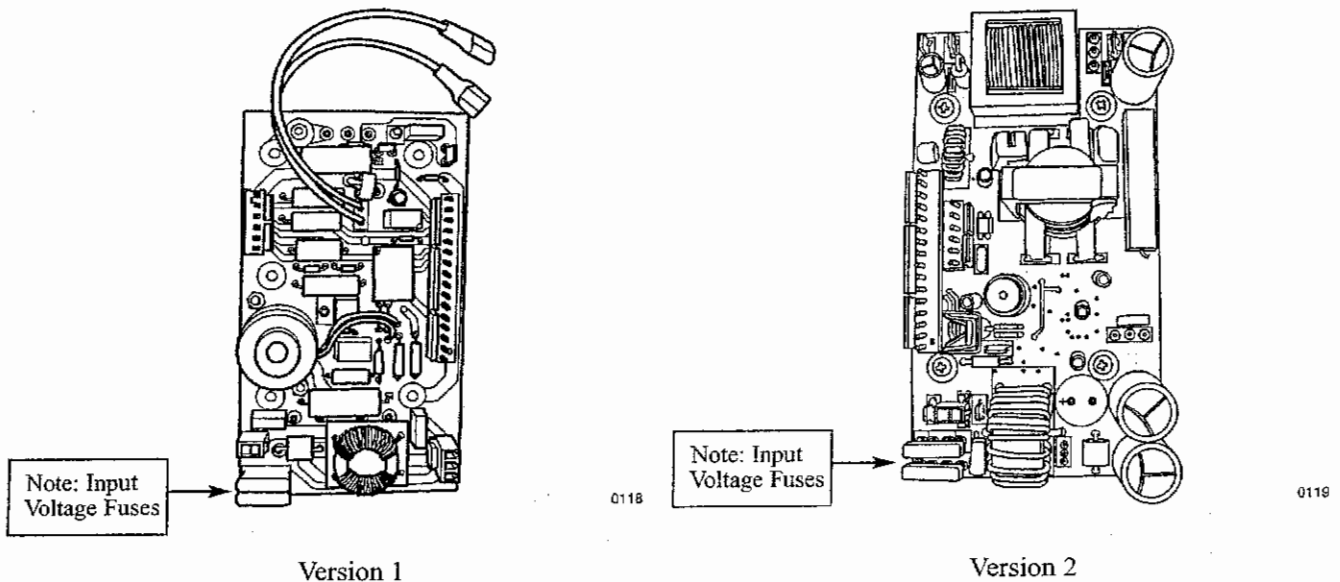

Figure 18 - Printed Wiring Boards

The GEM 72-volt system may employ one of two Printed Wiring Boards (PWBs). The latest version (see figure 18, Version 2) has an integrated DC-DC converter. The earlier version (see figure 18, Version 1) has the DC-DC converter mounted separately and behind the Printed Wiring Board. Both versions of the PWB serve principally as an interface and signal-conditioning module. Signals between many of the GEM circuits pass through the PWB including the turn signal module and blinker, fuse module and headlights, key switch and battery charger, direction/turf switches and the motor controller.

Operation

The PWB operates automatically when the Master Disconnect is in the "ON" position and the Key Switch is on.

Diagnosis and Testing

Because the PWB interacts with many different circuits, diagnosis and testing of the PWB is split between the Drive and Power System Troubleshooting Charts and the Accessory System Troubleshooting Chart. The circuit diagrams provided in this manual are also useful in isolation of problems associated with the PWB.

Removal of the Version 1 PWB

1. Turn off the Master Disconnect Switch.
2. Remove upper and lower dash.
3. Locate printed wire board and remove electrical connection, noting connection and orientation.
4. Remove four #6 screws from each corner of PWB.
5. Remove the PWB. Gently lift PWB off the converter pins, which are directly behind it.

Removal of the Version 2 PWB

1. Turn off the Master Disconnect Switch.
2. Remove upper and lower dash.
3. Locate the printed wire board and remove electrical connection, noting connection and orientation.
4. Remove the five 3/8" Tek screws that secure the ECM to the mounting plate and the ECM will fall forward.
5. Once you have the ECM forward, remove the four Phillips screws from the back of the mounting plate.
6. Remove the PWB.

Installation of PWB (both versions)

1. Reverse procedure to reinstall. Use care when positioning the PWB on the converter so they do not bend pins (version 1 boards only).

DC-DC CONVERTER

Description

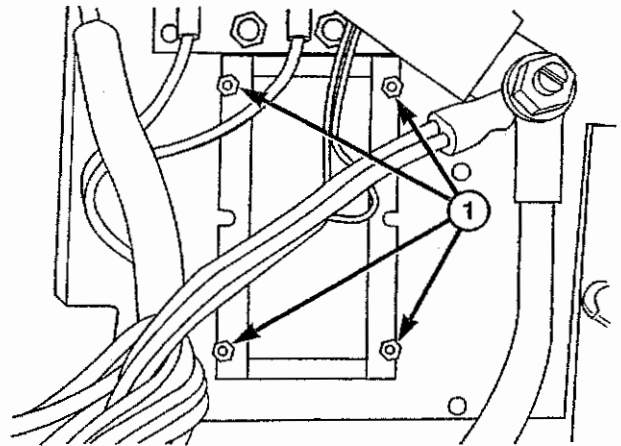

0107

Figure 19 - DC-DC Converter, Version 1 PWB

1. Mounting posts

As indicated in the previous section, the DC-DC converter is located either on the PWB, or is mounted directly under the PWB. In either case, the converter serves the same function; converting the high voltage delivered by the batteries (72 VDC) to lower voltage (12 VDC). The lower voltage is used to power all the devices that are part of the Accessory System - headlights, taillights, directional indicators, brake lights, horn and wipers.

Operation

The DC-DC converter functions automatically when the Master Disconnect is in the "ON" position.

Diagnosis and Testing

Diagnosis and testing of the DC-DC Converter is covered in the Accessory System Troubleshooting Chart. The circuit diagrams provided in this manual are also useful in isolation of problems associated with the DC-DC Converter.

Removal

Note: These replacement instructions apply only to systems that have DC-to-DC converters mounted separately and behind the Printed Wiring Board. For replacement instructions of the Version 2 PWB (which includes the DC-to-DC converter) see the Printed Wiring Board section.

1. Turn off the Master Disconnect Switch.
2. Remove upper and lower dash.
3. Locate the printed wiring board and remove electrical connections, noting connection and orientation.
4. Remove four #6 screws from each corner of PWB.
5. Gently lift PWB off the converter mounting posts located directly behind the PWB (see figure 18).
6. Using pliers, loosen and remove the four posts and remove the converter.

Installation

1. Hold the converter in place, and install the four mounting posts.
2. Set the PWB in place over top of the mounting posts and install the four #6 mounting screws.
3. Orient and attach all wires and cables to their proper connections.
4. Install the lower and upper dash.
5. Turn Master Disconnect Switch to on.

MAIN CONTACTOR

Description

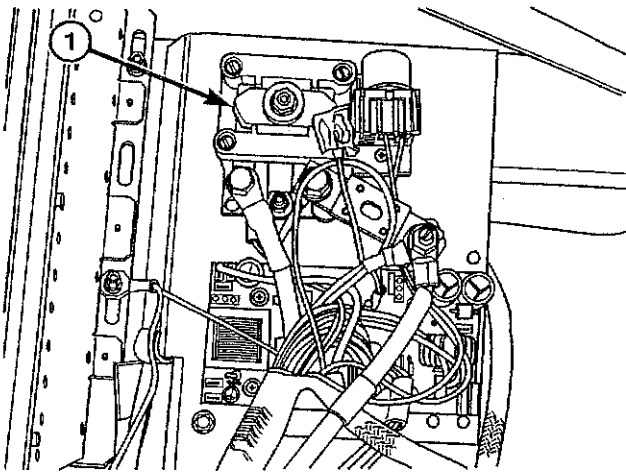

0112

Figure 20 - Main Contactor Location

1. Main Contactor

The Main Contactor is an electronically controlled switch that provides a high-current connection between the battery and the motor controller. It is located under the front dash, to the right of the battery charger and above the Printed Wiring Board.

Operation

The Motor Controller activates the Main Contactor if the Key Switch is on, and the Motor Controller determines high voltage, high current power should be supplied to the drive motor. The Motor Controller will not activate the Main Contactor if an error condition exists (see the Drive and Power System Error Codes chart).

Removal

1. Turn off the Master Disconnect Switch.
2. Remove upper and lower dash.
3. Locate main contactor.
4. Remove electrical connections, noting connection and orientation for each wire.
5. Remove screws that mount contactor to the front bulkhead.
6. Reverse procedure to reinstall. Double check cable connections.

Installation

1. Reverse procedure to reinstall. Double check cable connections.

MOTOR

Description

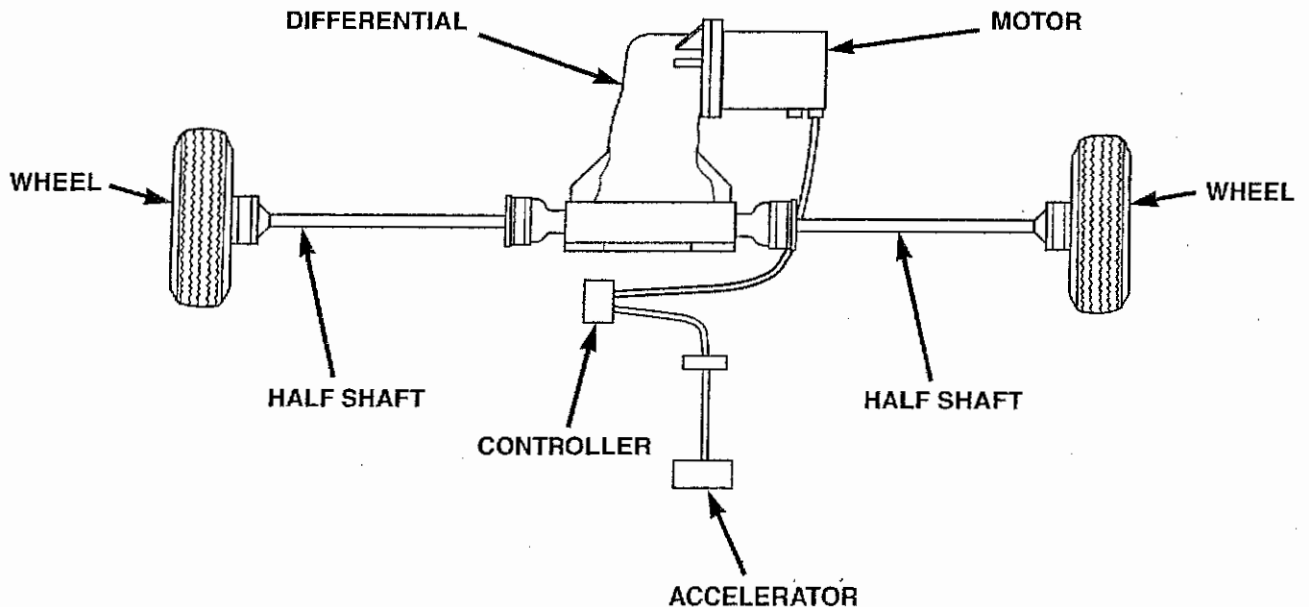

0044

Figure 21 - Motor Location

Power to the drivetrain is supplied by a 72-volt electric motor, which is attached to the differential. Motor speed (RPM) is monitored by a small magnet and speed sensor mounted to the center rear of the motor (see figure 22).

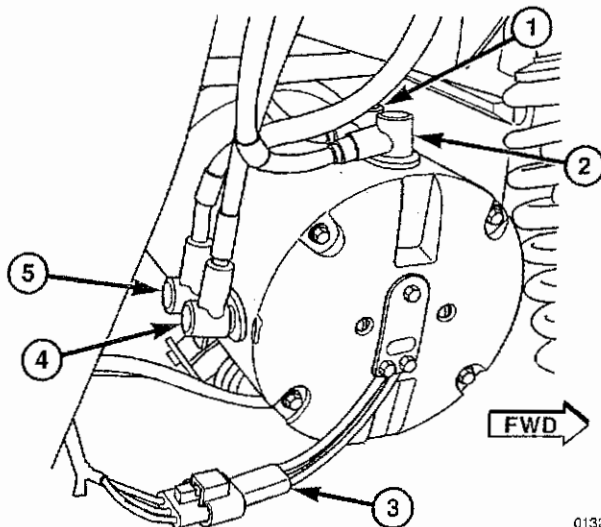

0132

Figure 22 - Motor Electrical Connections

1. Motor Field 1 (F1)
2. Motor Armature 2 (A2)
3. Speed Sensor Pigtail
4. Motor Armature 1 (A1)
5. Motor Field 2 (F2)

Operation

Motor activation and speed are controlled by a potentiometer located in the accelerator pedal in the cab. A splined cup in the motor is connected to a splined shaft on the pinion gear in the differential. Rotational motion of the motor's cup transmits that motion to the differential.

Diagnosis and Testing

Diagnosis and testing of the DC-DC Converter is covered in Drive and Power System Troubleshooting Chart B. The circuit diagrams provided in this manual are also useful in isolation of problems.

Removal

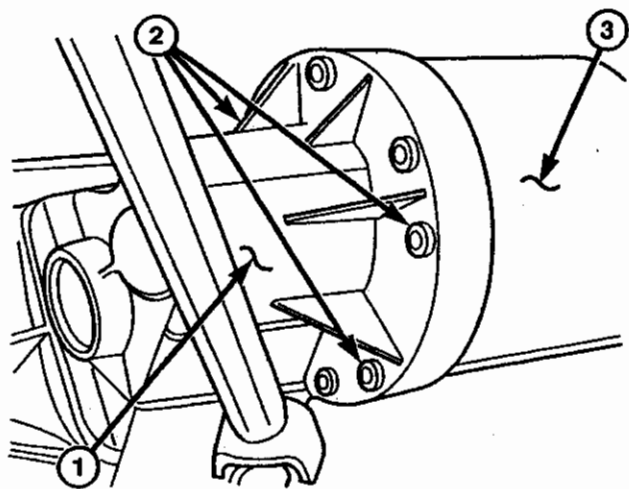

0045

Figure 23 - Motor to Differential Attachment

1. Differential
2. Mounting Bolts (3)
3. Motor

- 1) Remove lower bench seat cushion to access the Master Disconnect switch.
- 2) Switch master disconnect to off.
- 3) Raise vehicle off floor and support safely with jack stands.
- 4) Remove both front wheel assemblies for improved access
- 5) Disconnect power wires from top and rear of motor with 1/2-inch wrench, noting connections and locations (see figure 22).

- 6) Disconnect 3-wire pigtail at connector (see figure 22).
- 7) Remove 3 bolts from differential side of motor (see figure 23) with 7/16-inch wrench or socket, taking care to support motor, which weighs 30-40 pounds
- 8) Remove motor, noting orientation of power posts for reassembly, then pulling straight out.

Installation

- 1) Make sure to put a resilient bumper inside motor spline socket. The cupped end of the bumper will face outward. Be sure bumper is all the way in the spline socket.
- 2) Put a very light coating of Valvoline Special Moly Ep grease or equivalent on the splined differential shaft. (Too much grease will cause motor problems.)
- 3) Install motor, Making sure power posts on motor face the same direction as before.
- 4) Install 3 motor/differential mounting bolts with 7/16-inch wrench or socket. Make sure to add one drop of Loctite(r) to each motor/differential bolt. Torque bolts to 90 inch pounds.
- 5) Re-connect power wires to top and rear of motor with 1/2-inch wrench,
- 6) Replace both front wheel assemblies. Tighten wheel lug nuts just snug.
- 7) Lower vehicle to floor.
- 8) Torque wheel lug nuts to 30 foot pounds
- 9) Return master disconnect switch to ON position
- 10) Install lower bench seat cushion assembly. (see BENCH SEAT in BODY section.)

DESCRIPTION	NUT SIZE	BOLT HEAD SIZE	Use Loctite® 242	In. Lbs.	Ft. Lbs.	N-m
Motor to Differential	---	7/16"	YES	90	---	10
Wheel Lug Nuts	19mm	---	NO	---	30	41

Motor Magnet and Speed Sensor

Description

A small circular magnet is mounted to the motor spindle. A sensor, attached to a pigtail, sits in close proximity to the magnet. Access to the magnet and sensor is gained through a small plate in the center of the motor's end panel.

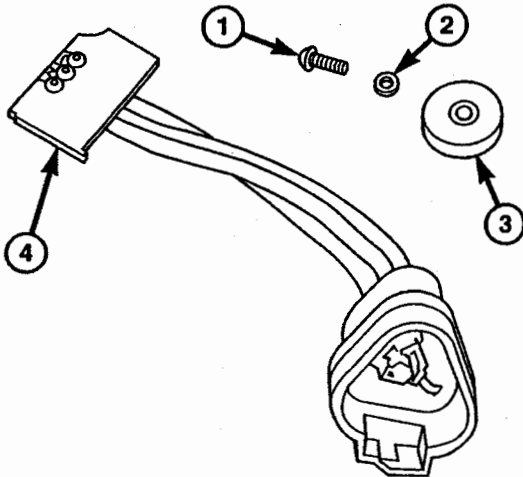

0058

Figure 24 - Speed Sensor & Magnet

1. Screw
2. Washer
3. Magnet
4. Speed sensor

Operation

When the motor's armature rotates the magnet rotates also. The sensor detects the magnet's motion, and transmits a signal through its pigtail to the motor controller.

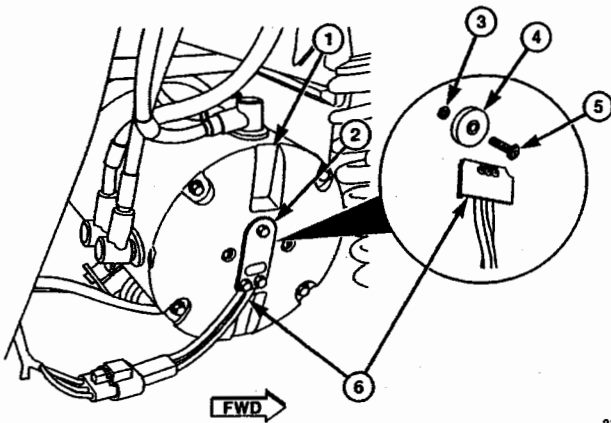

0164

Figure 25 - Speed Sensor/Magnet Location

1. Motor
2. Cover plate mounting holes
3. Washer
4. Magnet (bushing underneath)
5. Magnet mounting bolt
6. Speed Sensor

Removal

1. Remove (3) small screws attaching cover plate to motor end panel.
2. Remove plate and lift out sensor/pigtail assembly.
3. Remove small bolt in center of magnet with 5/64" hex wrench.
4. Remove magnet and bushing.

Installation

1. Insert hex socket head bolt through magnet, then bushing, then attach to motor's armature.
2. Position sensor/pigtail.
3. Install cover plate and attach with mounting bolts.

BATTERY DISCHARGE INDICATOR (BDI)

Description

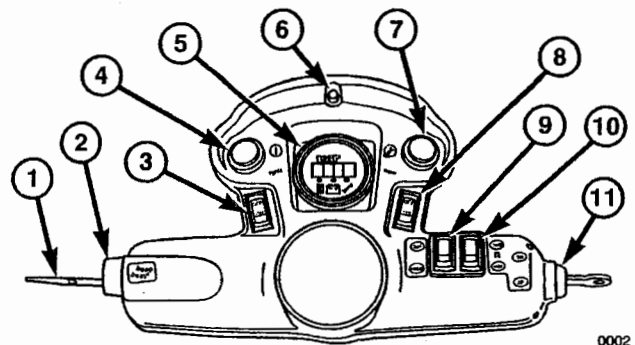

0002

Figure 26 - Instrument Pod

1. Turn Signal Lever
2. Horn Button
3. Light Switch
4. L-Turn Signal/Brake Warning Light
5. Battery Discharge Indicator (BDI)
6. Charge Status Light
7. R-Turn Signal/Seat Belt Warning Light
8. Windshield Wiper Switch
9. Road/Turf Switch
10. Vehicle Direction Switch
11. Key Switch

The "Battery Discharge Indicator" is located in the center of the Instrument Pod and performs the following function.

1. Battery Discharge Indicator (BDI)
2. MPH Speed Indicator
3. Accumulated Miles
4. Fault Code Display

Operation

At key on, the BDI will display remaining battery capacity. The indicator will then alternate between MPH and battery status. The remaining battery capacity is displayed in 3 digits and the battery icon will light. For example, 100 means 100% charge. When the key is turned off, the LED display will show the Odometer reading and the hourglass icon will light.

NOTE: If an error code is displayed, it is preceded by a minus sign and the tool icon will light. For a description and explanation of common fault codes see the "Drive and Power System Error Codes," in this section.

Removal

1. Remove upper dash panel. (See UPPER DASH in BODY section).
2. Remove lower dash panel. (See LOWER DASH in BODY section).
3. Remove RS and LS pod covers. (See POD COVERS in this section).
4. Disconnect 5-way connector at back of BDI (see figure 24 - item 3).
5. Remove (2) white knurled knobs at back of BDI mounting bracket (see figure 25 - item 4).
6. From steering wheel side, pull BDI free of pod.

1. Instrument Pod
2. BDI
3. BDI mounting bracket
4. 5-way connector
5. Knurled BDI mounting hardware

Installation

1. Insert BDI in pod from steering wheel side.
2. Install (2) white knurled knobs through bracket into BDI (see figure 25 - item 4).
3. Attach 5-way connector to back of BDI (see figure 25 - item 3).
4. Install RS and LS pod covers.
5. Install lower dash panel.
6. Install upper dash panel.

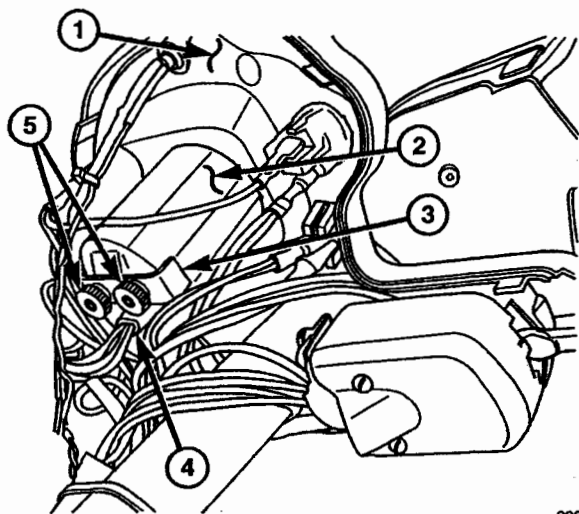

0069

Figure 27 - Instrument Pod (Rear View)

ACCESSORY SYSTEM

Description

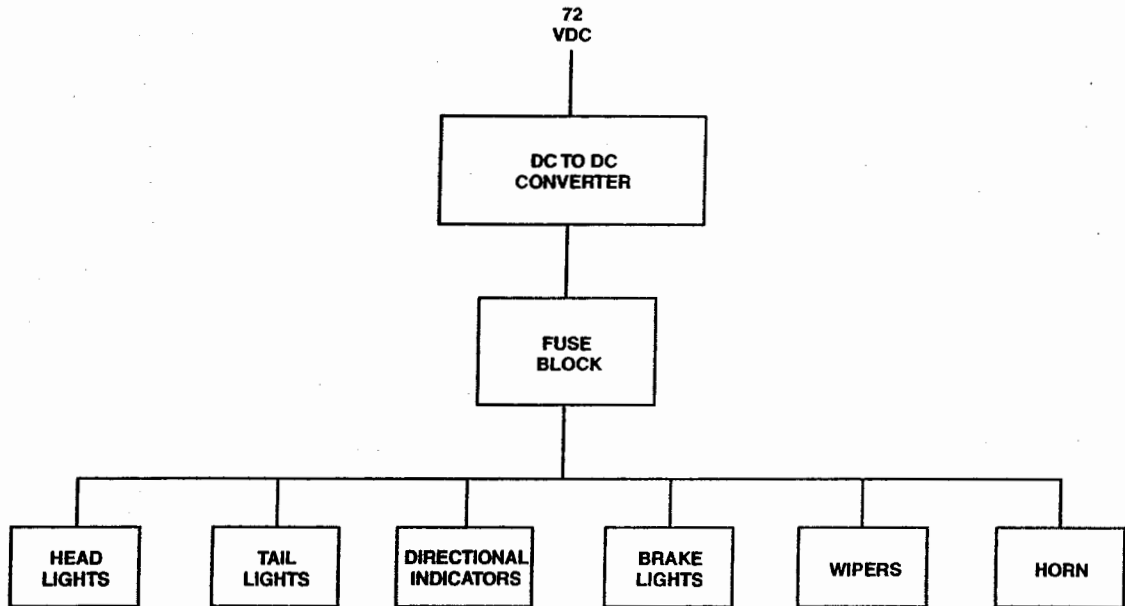

0117

Figure 28 - Accessory System Diagram

The standard Accessory System components for the GEM are essential for safe driving and consist of the headlights, taillights, directional indicators, and brake lights, horn, and wipers. Some vehicles are equipped with a radio and heater that are considered optional equipment and are not covered by this service manual.

Operation

Standard accessories receive their 12-volt power from the fuse protected DC-to-DC converter. The DC-to-DC converter receives 72-volt input power directly from the six batteries and requires no user action for its operation. All other components of the Accessory System function identical to those devices in a standard automobile.

The two headlights are 12-volt single filament incandescent bulbs. A rocker switch (see figure 8, item 3) located on the instrument pod activates headlights.

Taillights and brake lights are 12-volt dual filament incandescent bulbs. One filament is used for directional indicators and brake lights. The taillight filament is activated when the headlights are turned on.

There are 4 directional indicators, left and right front, and left and right rear. Turn signal lever (see figure 8, item 1) located on the left side of the instrument pod activates the directional indicators.

The horn provides a single continuous tone when the horn button is pressed. Horn button (see figure 8, item 2) is located on the left side of the instrument pod.

A single speed DC motor powers the wipers. The motor automatically returns the wipers to the "Parked" position when the wipers are turned off. A rocker switch (see figure 8, item 8) on the right side of the instrument pod activates the wipers.

Diagnosis and Testing

The purpose of this section is to aid in the isolation of problems with the accessory system. Unlike the drive system, the BDI does not provide any error codes to aid in troubleshooting problems with accessories. The most common problems with the accessory system are open lamp filament or blown fuse. For problems that cannot be resolved by lamp and fuse replacement, refer to the "ACCESSORY SYSTEM TROUBLESHOOTING CHART" and the wiring diagrams provided.

As was the case with the Drive System, the information provided in this section is a guide only. There are numerous variations in the skill level of personnel that service this vehicle. This manual cannot possibly accommodate

all skill levels and provide advice for each. A basic understanding of electronics and troubleshooting techniques is required.

ACCESSORY SYSTEM TROUBLESHOOTING CHART

Symptom	Problem Description	Diagnostic Steps	Corrective Action
1	A single bulb (headlight, taillight or directional indicator) does not work.	Remove the bulb (see bulb removal replacement instructions below), examine for open filament or measure the filament with an ohmmeter.	If the filament is visibly open or the filament resistance is greater than 100 ohms -replace the bulb.
2	The headlamps, tail lamps, the front and rear directional indicators, horns and wipers do not work.	Using a voltmeter, test for voltage at the following location: * +72 V at PWB J4 Pin 1 * 0 V at PWB J4 Pin 2 * +12 V at PWB J1 Verify connectors on J4 and J1 have not come loose.	Systems with separate PWB and DC-to-DC Converter: If there is +72 V at J4, but there is no +12 V at J1, replace the DC-to-DC converter. If there is +12 V at J1, make sure the wire connecting J1 to the fuse block has not come loose. Systems with combined PWB and DC-to-DC Converter: If there is +72 V at J4, but there is no +12 V at J1, replace the PWB
3	Headlights and taillights do not work, but front and rear directional indicators do work.	Remove the 10 amp fuse in the fuse block and visual inspect or measure with an ohmmeter to determine if it is open.	Replace fuse if open. If fuse is not open, use "Headlight and Front Turn Signal Circuit" diagram (headlights and taillights share many common circuitry) and a voltmeter to isolate problem.
4	Both rear turn lamps and tail lamps do not work.	Verify tail light harness connection with power harness.	If connection is not loose, use "Taillight and Rear Turn Signal Circuit" diagram and a voltmeter to isolate problem.
5	The tail lamps do not work (when the headlamps are turned on), but the rear directional indicators do work.	Disconnect the tail light harness from the rear harness. Using an ohmmeter, measure resistance from pin 2, 3 or 4 to ground. The resistance should measure no more than 100 ohms.	If the resistance to ground is higher than 100 ohms for either pin 2,3, or 4, check for a loose ground connection.
6	The rear directional indicators do not work, but the front directional indicators do work.	There is probably a loose or broken connection between the signal stat in the IP harness, to the PWB, and rear harness.	Use "Taillight and Rear Turn Signal Circuit" diagram and a voltmeter to isolate the problem.
7	Horn does not work	Check the 3 amp fuse (there are 2; one is for the horn).	Replace the fuse if open. If the fuse is not open, use "Horn and Wiper Circuit" diagram and a voltmeter to isolate the problem.
8	Wipers do not work	The wiper motor has overload protection and may stop working for a short period of time if the windshield is very dry. Wait a moments and try operating the wipers again. If the wipers fail to operate, check the 7.5 amp fuse in the fuse block.	Replace the fuse if open. If the fuse is not open, use "Horn and Wiper Circuit" diagram and a voltmeter to isolate the problem.

ACCESSORY SYSTEM COMPONENT REPLACEMENT

Fuse Replacement

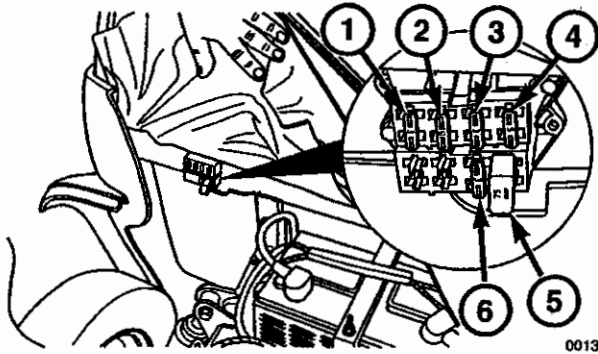

Figure 29 - Fuse Box

- | | |
|-----------------------|--------------------------|
| 1. Turn signal 3A ATC | 4. Brake 5A ATC |
| 2. Headlights 10A ATC | 5. Window Wiper 7.5A ATC |
| 3. Horn 3A ATC | 6. Accessory plug 3A ATC |

1. Disconnect power as described above.
2. Open hood as described in Body Panels and Accessories Section.
3. Locate fuse block on upper cross member.
4. Locate rubber splashguard on passenger side cross member. Remove rivet at bottom of splashguard with a flat screwdriver, pulling out center portion of rivet. Lift splashguard to expose fuse block.
5. Locate blown fuse using volt/ohm meter.
6. Use fuse puller to remove fuse.
7. Replace with appropriate size fuse. See ECM Troubleshooting section for appropriate sizes.
8. Reverse procedure to reinstall.

Headlight Replacement

1. Open hood.
2. Remove light from mounting bracket. Disconnect ground wire and spade terminal, noting connections and orientation.
3. Reverse procedure to reassemble.
4. Adjust headlight as follows: Position the front of the car about five feet away from a wall. Turn on headlights and adjust them so the center of the beam on the wall is about one inch lower than the center of the light on the car.

Front Turn Indicator Lamp Replacement

1. Open hood.
2. Remove lock nut from light and disconnect power and ground wires.
3. Replace light assembly.
4. Reverse procedure to reassemble.

Rear Turn Indicator Lamp Replacement

1. Remove two Phillips-head screws holding lens in place.
2. Remove lens.
3. Twist bulb counter-clockwise to remove, noting type of bulb, and replace. (2057/2067)
4. Reverse procedure to reassemble.

Wiper Motor Replacement

1. Open hood and remove upper dash. (See body panels and accessories)
2. Remove wiper arm and blade with 13mm socket; or for the style without nut, gently pry off arm with a large screwdriver.
3. Remove plastic from windshield sill by lifting up and rotating slightly clockwise (if applicable).
4. Use 3/8-inch socket or wrench to remove Tek screws from wiper bracket.
5. Disconnect electrical connection from wiper motor. Use 15/16-inch wrench or adjustable wrench to remove capture, nut, washer and rubber bushing from wiper shaft. Remove wiper from windshield sill.
6. Reverse procedure to reinstall.

Instrument Pod Removal

1. Remove upper and lower dash. (See body panels and accessories)
2. Remove steering column covers. (See body panels and accessories)
3. Remove steering wheel.
4. Remove 4 self-tapping screws.
5. Reverse procedure to install.

Headlight Switch Removal

1. Locate bad switch.
2. Remove wires, noting location and orientation.
3. Looking at it from the rear, push tabs in with a flat screwdriver, and press out front side.
4. To install new switches from the front, insert switch in proper orientation and press firmly. Switch will snap into place.
5. Reconnect wires and reassemble.

Key Switch Replacement

1. Note location of wires on back of key switch (Red/Grn on top, and Org/Grn in middle) and disconnect.
2. Remove two Phillips-head screws holding key assembly in place.
3. Remove key assembly.
4. Reverse procedure to reassemble.

HEAD LIGHT AND FRONT TURN SIGNAL CIRCUIT

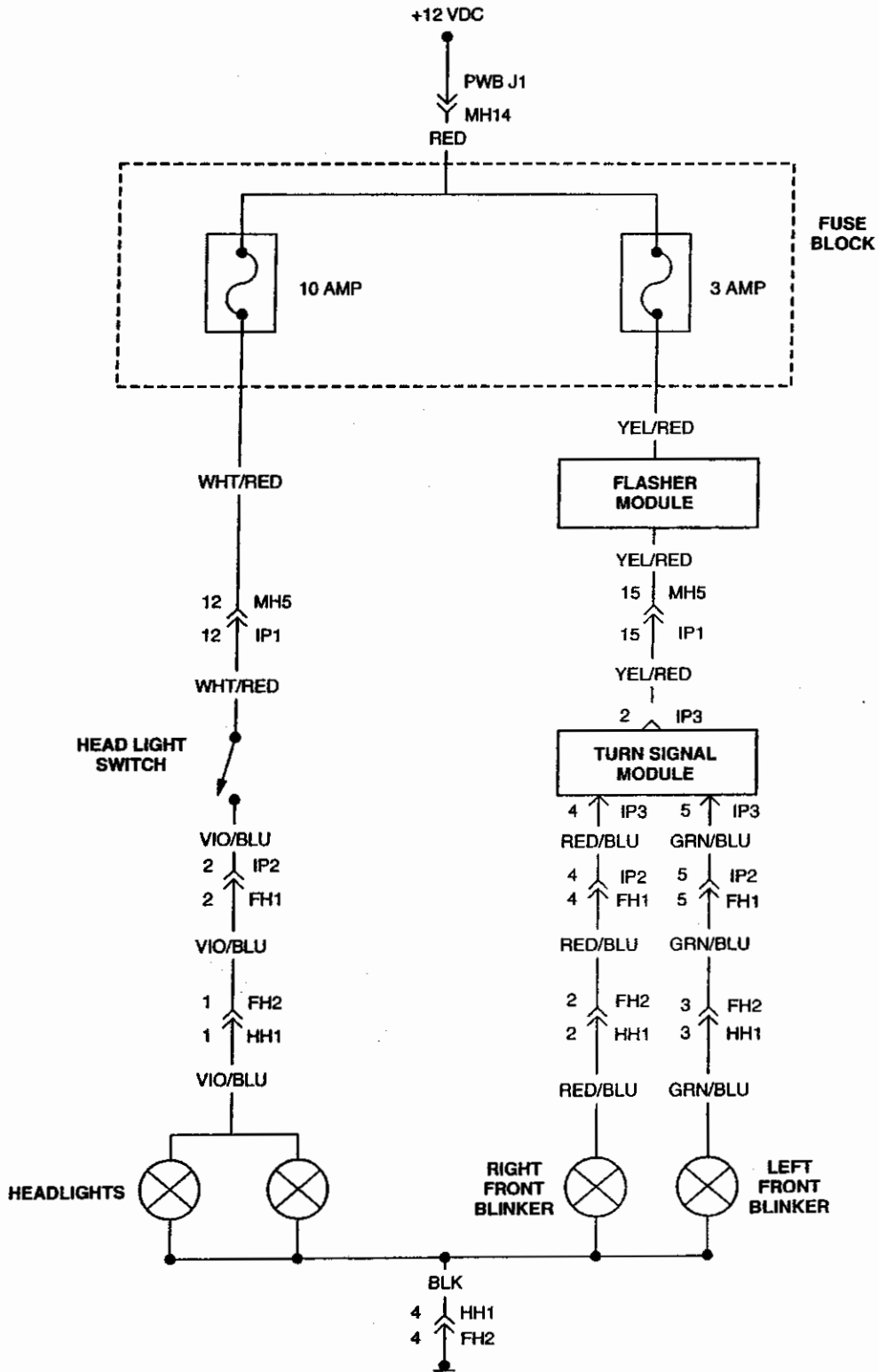

HORN AND WIPER CIRCUIT

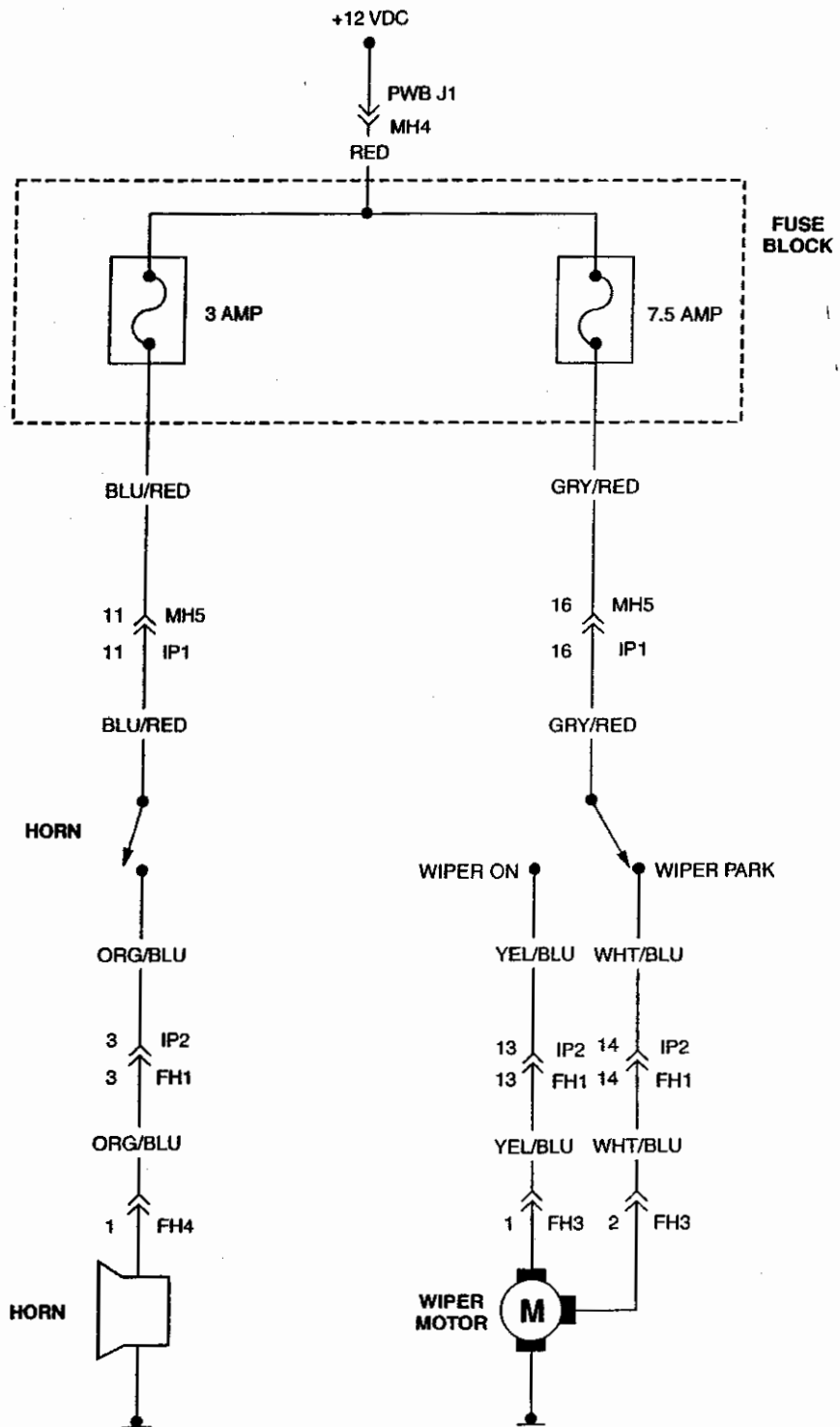

TAIL LIGHT AND REAR TURN SIGNAL CIRCUIT

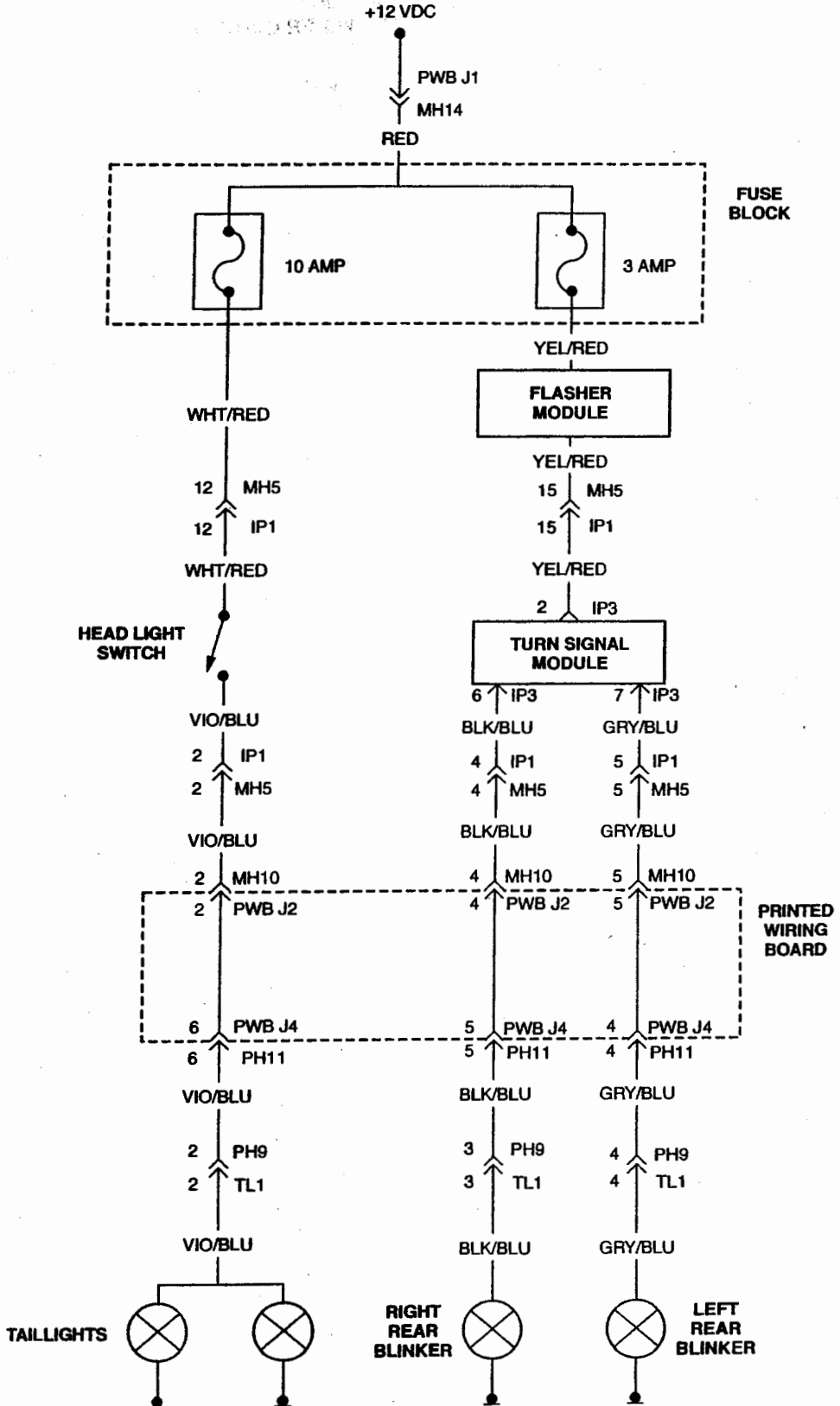

BRAKE LIGHT AND WARNING CIRCUIT

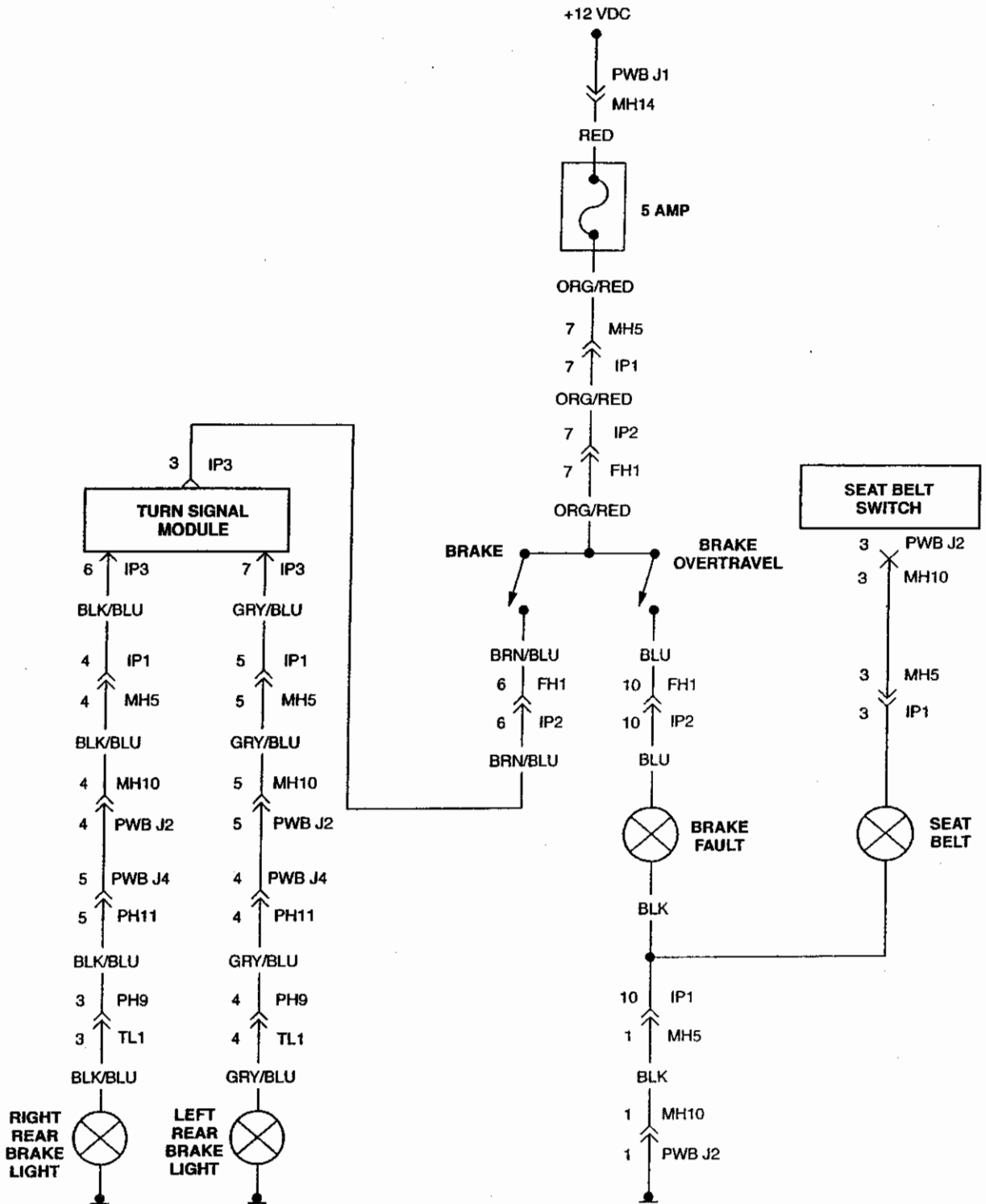

BATTERY CHARGER CIRCUIT

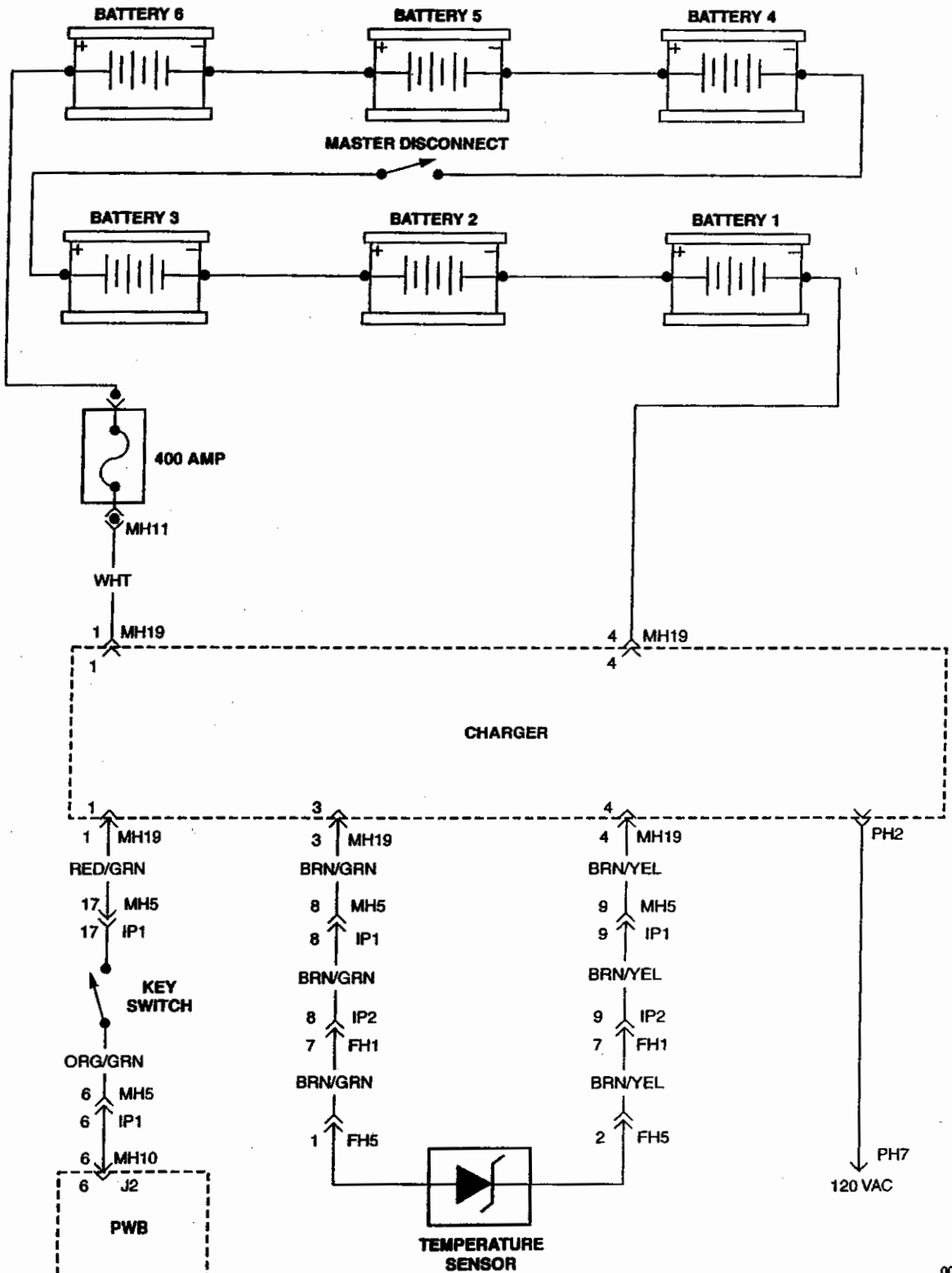

MAIN CONTACTOR CIRCUIT

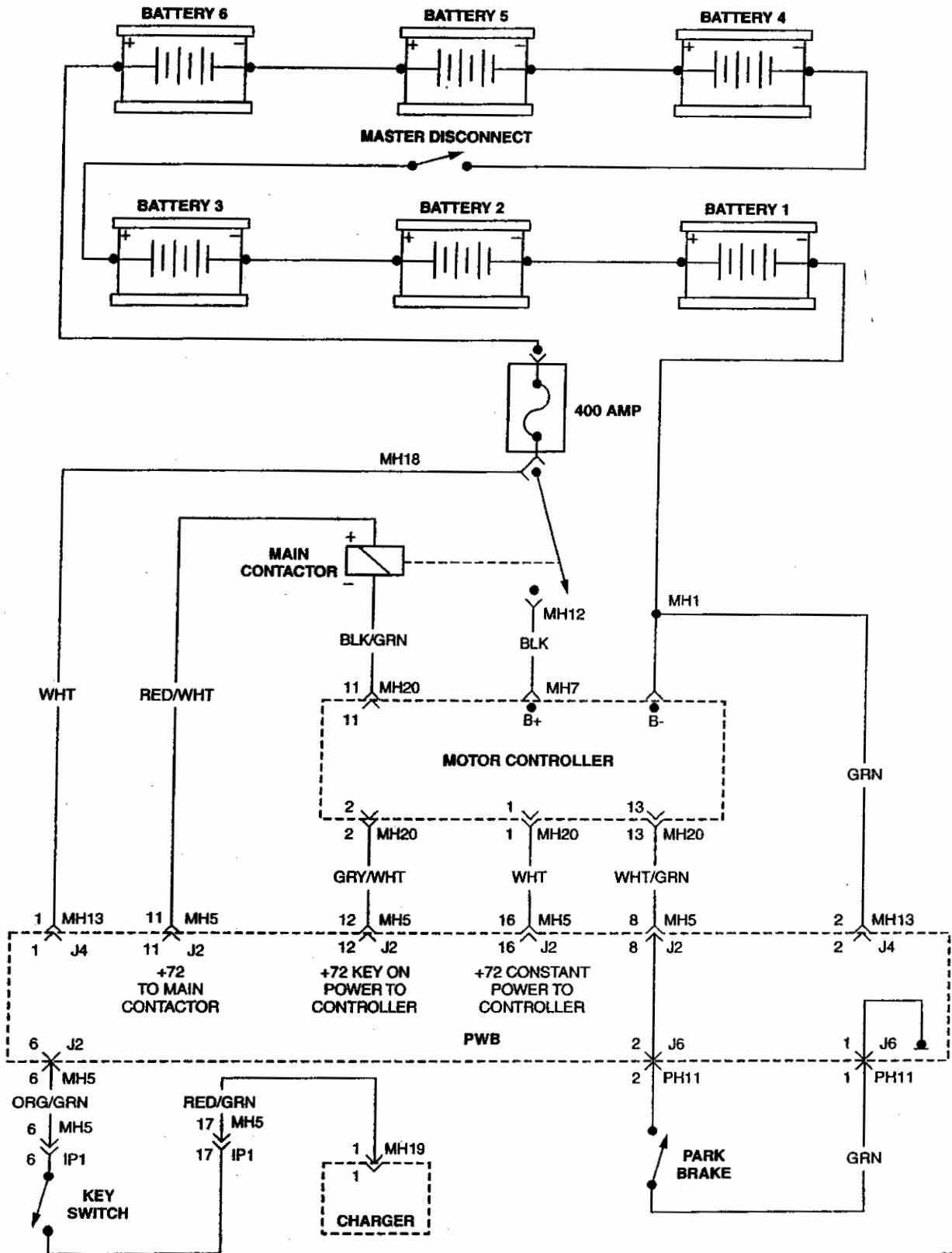

MOTOR CIRCUIT

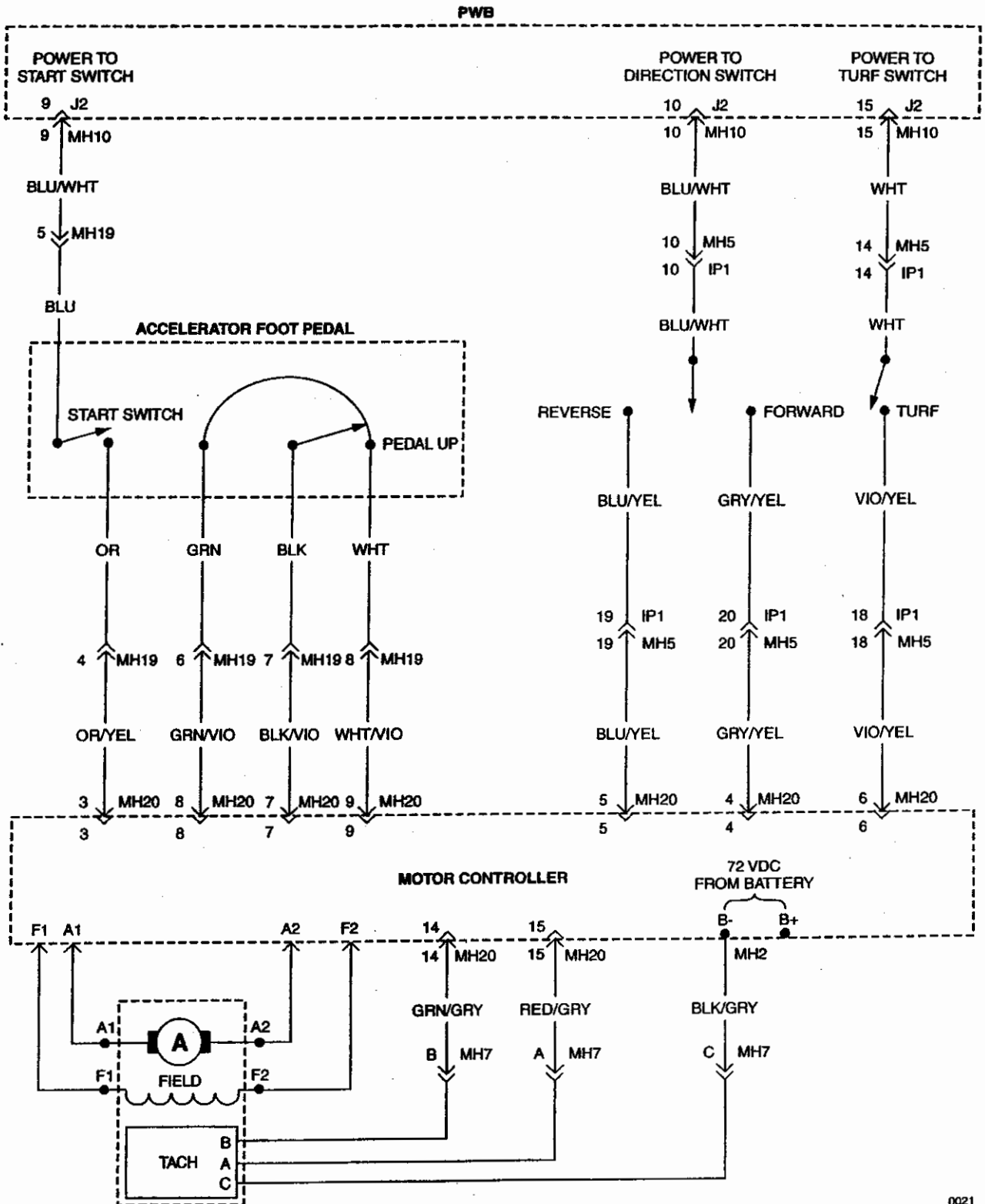

HARNESS AND CONNECTOR DRAWINGS

HEAD LIGHT HARNESS

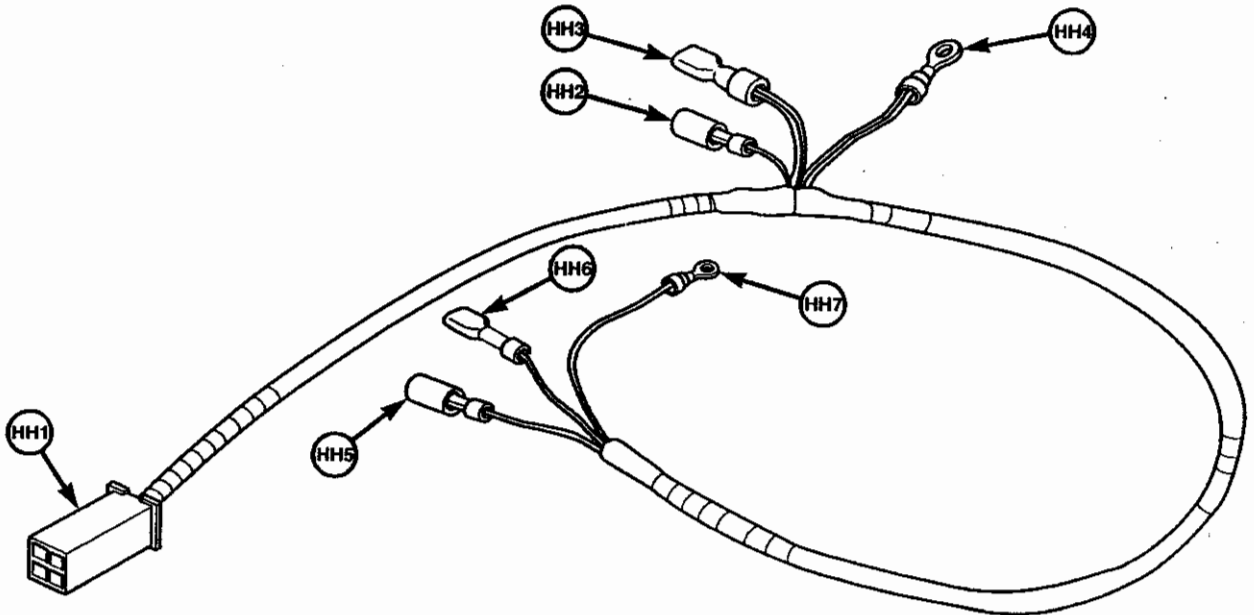

0078

HEADLIGHT HARNESS CONNECTIONS

Connector Number	Connects To	Number of Pins in Connector
HH1	Front Harness	4
HH2	Left Headlight	1
HH3	Left Front Blinker	1
HH4	Ground	1
HH5	Right Headlight	1
HH6	Right Blinker	1
HH7	Ground	1

PIN LOCATIONS FOR HEADLIGHT HARNESS MULTI-PIN CONNECTORS

Connector Illustration	Connector Number	Number of Pins in Connector
	HH1	4

0165

FRONT HARNESS

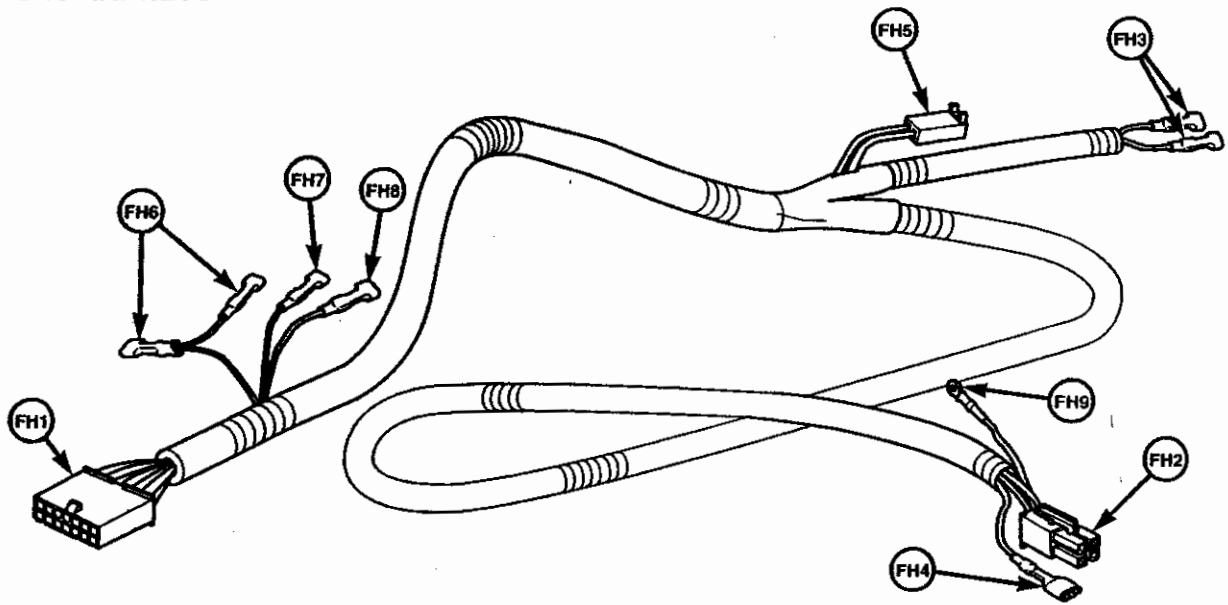

0079

FRONT HARNESS CONNECTIONS

Connector Number	Connects To	Number of Pins in Connector
FH1	IP Harness	14
FH2	Headlight Harness	4
FH3	Wiper Motor	2
FH4	Horn	1
FH5	Over-Temperature Sensor (Schott charger only)	2
FH6	Orange	2
FH7	Top of Switch (Brown)	1
FH8	Bottom of Switch (Blue)	1
FH9	Ground	1

PIN LOCATIONS FOR FRONT HARNESS MULTI-PIN CONNECTORS

Connector Illustration	Connector Number	Connects To	Number of Pins in Connector
<p>0108</p>	FH1	IP Harness	14
<p>0091</p>	FH2	Headlight Harness	4
<p>0166</p>	FH5	Over-Temperature Sensor (Only for Schott Charger)	2

INSTRUMENT PANEL HARNESS

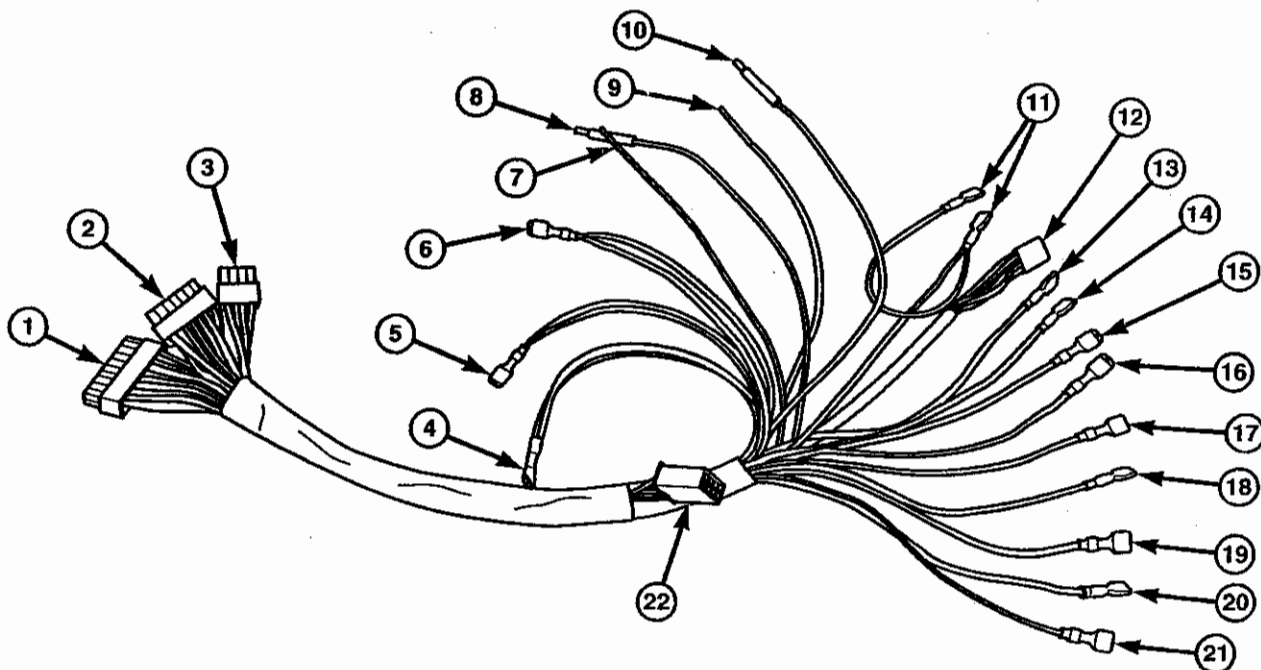

0125

IP HARNESS CONNECTIONS

Connector Number	Connects To	Number of Pins in Connector
IP1	Main Harness MH5	20
IP2	Front Harness FH1	14
IP3	Battery Discharge Indicator	8
IP4	Blue - Left Turn Indicator Light	1
IP5	Red - Right turn Indicator Light	1
IP6	Purple - Headlight	1
IP7	Org/Green - Ignition	1
IP8	Brn/Red - Horn pin 4	1
IP9	Red/Grn - Ignition	1
IP10	Org/Brn - Horn pin 3	1
IP11	Black - Turn Indicator	2
IP12	BDI	8
IP13	Blu/Yel F/R	1
IP14	Org/Wht - F/R	1
IP15	Gry/Yel - F/R	1
IP16	Vio/Yel - R/T	1
IP17	White - R/T	1
IP18	Wht/Blu - Wiper	1
IP19	Gry/Red - Wiper	1
IP20	Yel/Blu - Wiper	1
IP21	Wht/Red - Headlights	1
IP22	Turn Signal Module	8

PIN LOCATIONS FOR IP HARNESS MULTI-PIN CONNECTORS

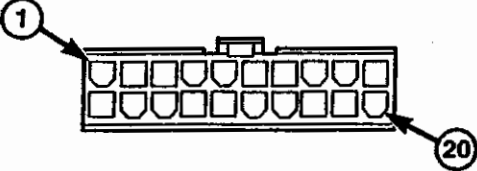
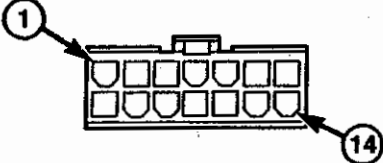
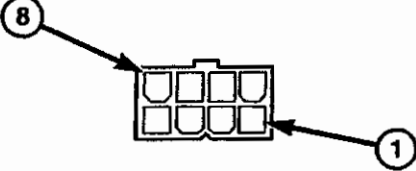
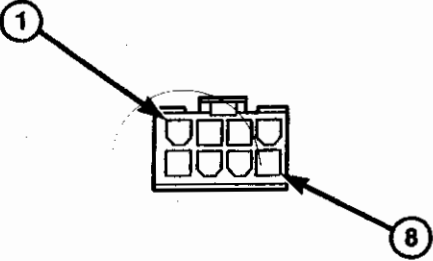
Connector Illustration	Connector Number	Connects To	Number of Pins in Connector
 <p style="text-align: right; margin-right: 20px;">0127</p>	IP1	Main Harness MH5	20
 <p style="text-align: right; margin-right: 20px;">0126</p>	IP2	Front Harness FH1	14
 <p style="text-align: right; margin-right: 20px;">0097</p>	IP3	BDI	8
 <p style="text-align: right; margin-right: 20px;">0100</p>	IP12 & IP22	BDI & Turn signal Module	8

MAIN HARNESS

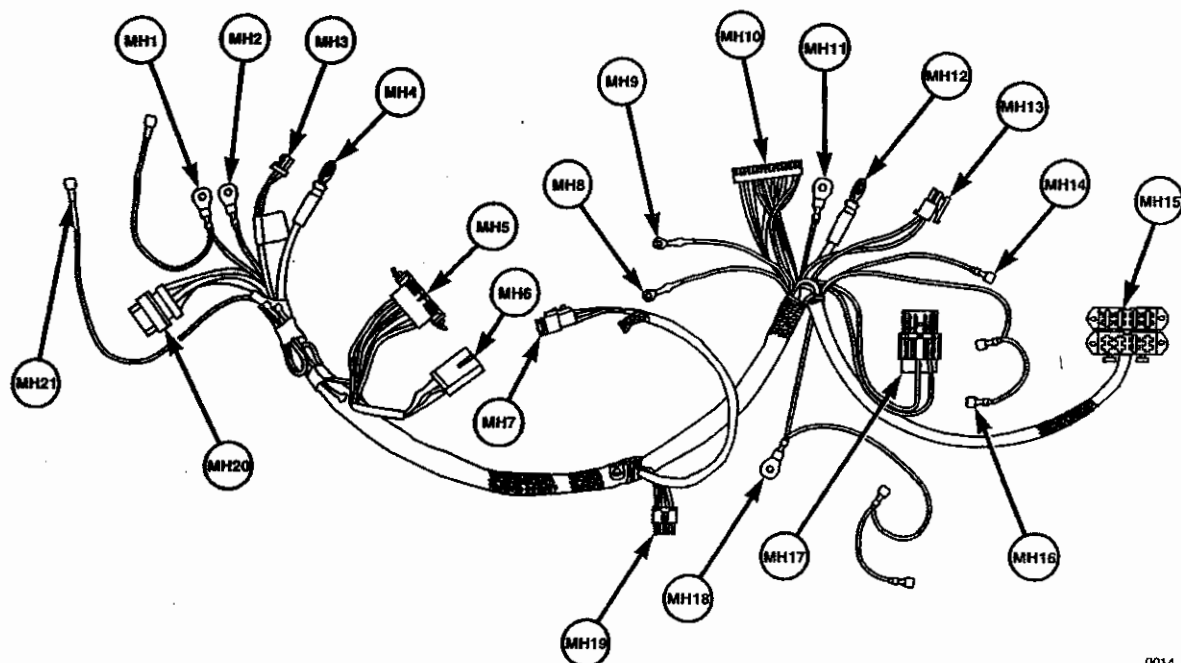

0014

MAIN HARNESS CONNECTIONS

Connector Number	Connects to	Number of Pins in Connector
MH1	Controller B - (Female Spade and Circular Lug - GRN)	2
MH2	Controller B- (Circular Lug - BLK)	1
MH3	Motor Controller 8 MH4 MotorController B+	1
MH5	IP Harness	20
MH6	IP Harness (Battery Discharge Indicator)	8
MH7	Tachometer	3
MH8	Main Contactor Coil Black (Circular Lug - BLK)	1
MH9	Main Contactor Coil (Circular Lug - RED/WHT)	1
MH10	PWB J2	16
MH11	Fuse Circular Lug -WHT	1 connector, 3 wires
MH12	Main Contactor	1
MH13	PWB J4	2
MH14	PWB J1 (J7 on old PWB)	1
MH15	Fuse Block	9
MH16	Female Spade (Violet/Red)	2
MH17	Flasher Module	2
MH18	Firewall Chassis Ground (2 Female Spade, 1 Circular Lug - BLK)	3
MH19	Accelerator Foot pedal	8
MH20	Motor Controller	23
MH21	Zivan Charger (Female Spade - RED)	1

PIN LOCATIONS FOR MAIN HARNESS MULTI-PIN CONNECTORS

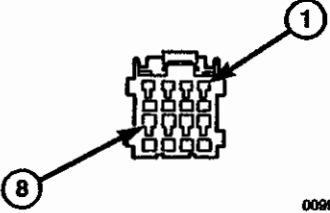
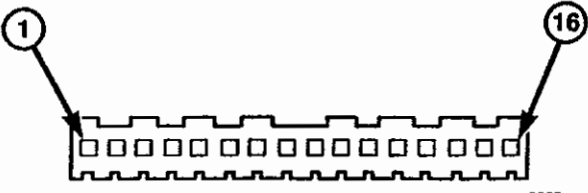
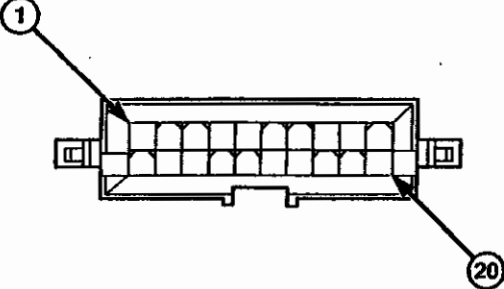
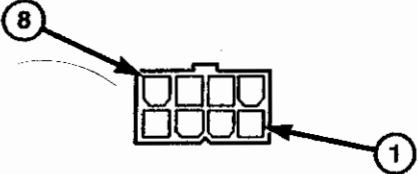
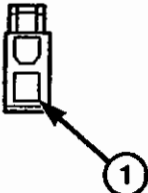
Connector Illustration	Connector Number	Connects To	Number of Pins in Connector
 <p style="text-align: center;">0098</p>	MH3	Motor Controller	8
 <p style="text-align: center;">0083</p>	MH10	PWB J2	16
 <p style="text-align: center;">0092</p>	MH5	IP Harness	20
 <p style="text-align: center;">0087</p>	MH6	IP Harness (Battery Discharge Indicator)	8
 <p style="text-align: center;">0086</p>	MH13	PWB J4	2

5 - 44 ELECTRICAL

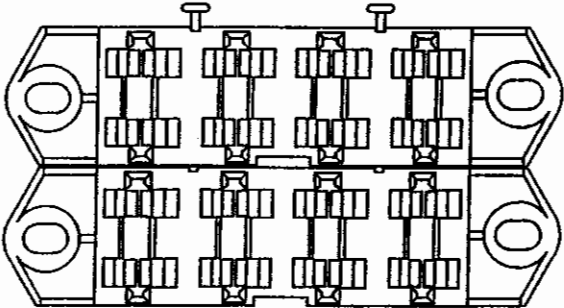
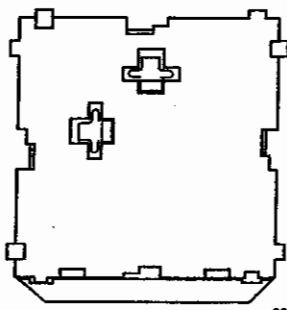
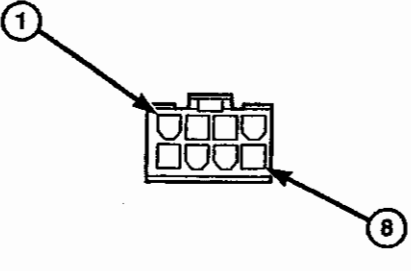
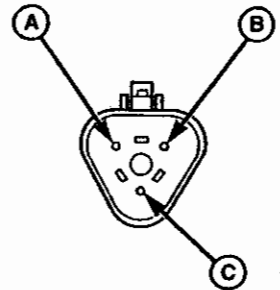
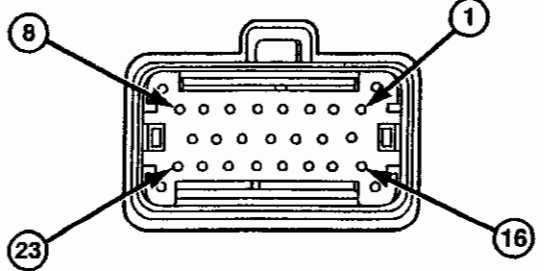
 <p style="text-align: right;">0101</p>	<p>MH15</p>	<p>Fuse Block</p>	<p>9</p>
 <p style="text-align: right;">0095</p>	<p>MH17</p>	<p>Flasher Module</p>	<p>2</p>
 <p style="text-align: right;">0100</p>	<p>MH19</p>	<p>Battery Charger</p>	<p>8</p>
 <p style="text-align: right;">0098</p>	<p>MH7</p>	<p>Tachometer</p>	<p>3</p>
 <p style="text-align: right;">0094</p>	<p>MH20</p>	<p>Motor Controller</p>	<p>23</p>

ZIVAN HARNESS

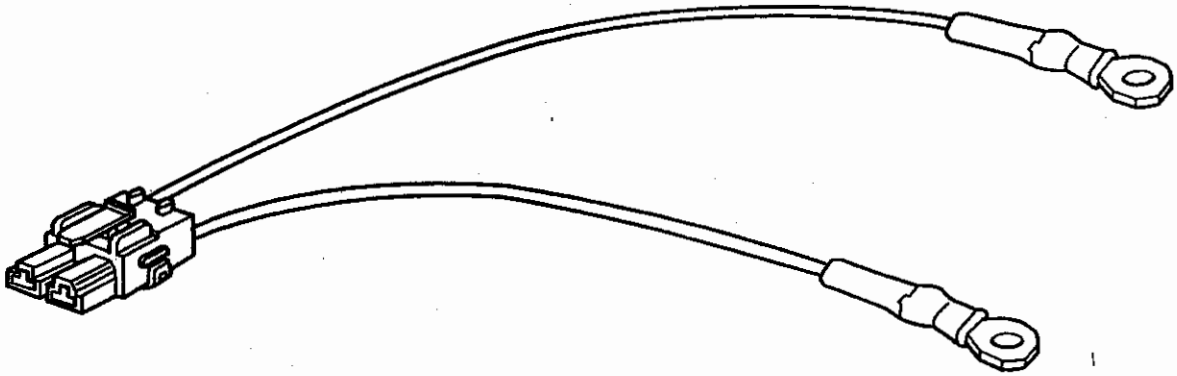

0076

ZIVAN HARNESS CONNECTIONS	
Connects To	Number of Pins in Connector
72 volt Power Harness	2
B-	1
Black Fuse Wire	1

POWER HARNESS

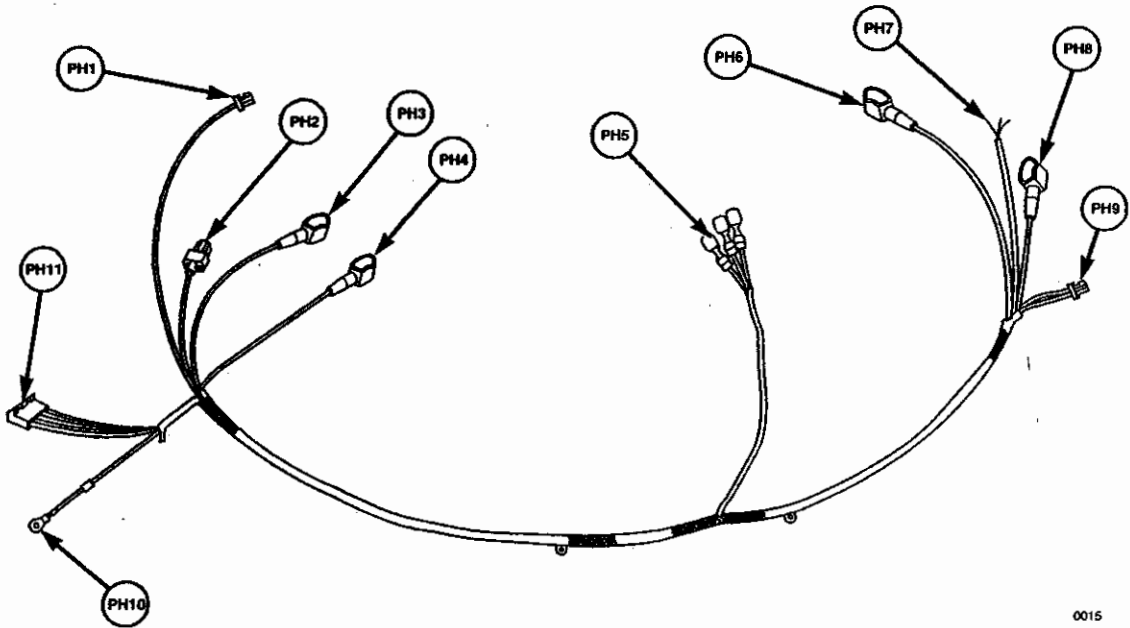

0015

2 & 4 PASSENGER POWER HARNESS CONNECTIONS

Connector Number	Connects To	Number of Pins in Connector
PH1	GE Motor Controller B-	1
PH2	AC Power Input for Battery Charger	1
PH3	B5- Battery 5 Negative Terminal	1
PH4	B6+ Battery 6 Positive Terminal	1
PH5	Parking Brake	3
PH6	B1- Battery 1 Negative Terminal	1
PH7	AC Power Cord (Male)	3
PH8	B4+ Battery 4 Positive Terminal	1
PH9	Tail Light Harness	4
PH10	Fuse (400 Amp)	1
PH11	PWB J3	6

PIN LOCATIONS FOR POWER HARNESS MULTI-PIN CONNECTORS

Connector Illustration	Connector Number	Connects To	Number of Pins in Connector
<p>0091</p>	PH9	Tail Light Harness	4
<p>0090</p>	PH11	PWB J6	6

TAIL LIGHT HARNESS

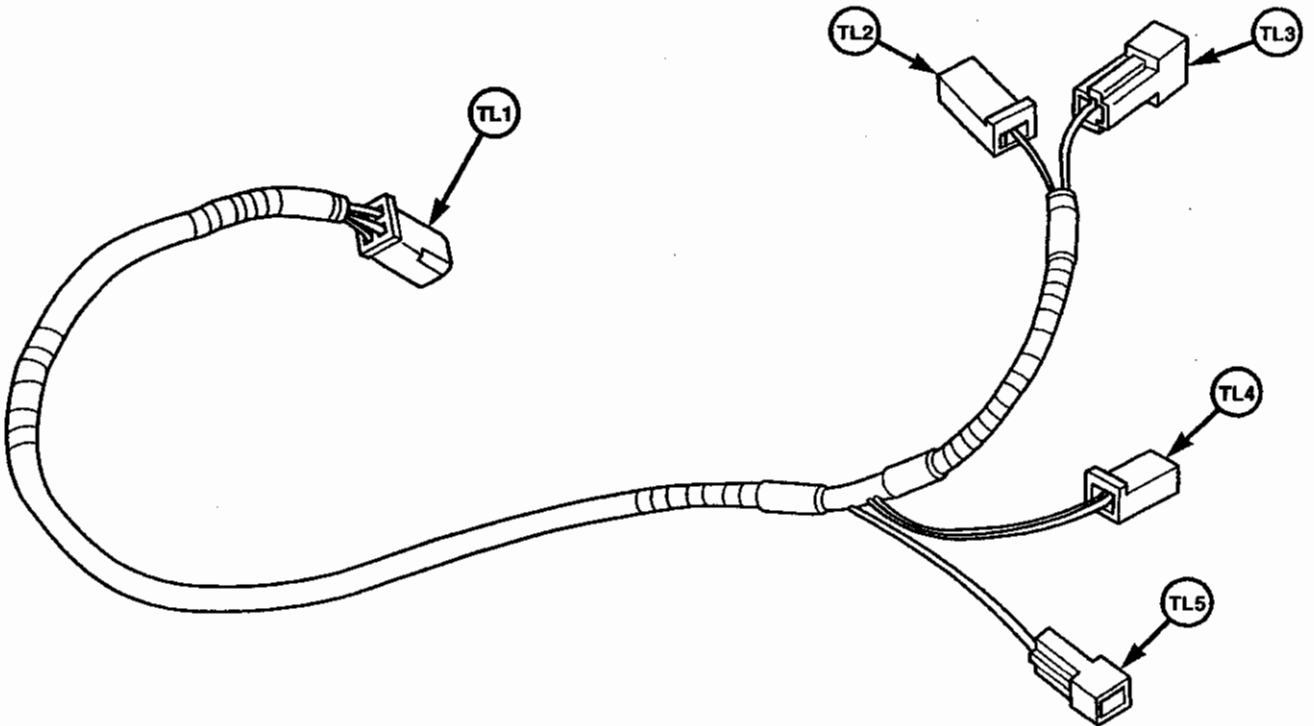

0075

TAIL LIGHT HARNESS CONNECTIONS		
Connector Number	Connects To	Number of Pins in Connector
TL1	Power Harness	4
TL2	Left Tail Light	1
TL3	Left Rear Blinker	1
TL4	Right Tail Light	1
TL5	Right Rear Blinker	1

CONTENTS

Tires	6-1
Radial-Ply Tires	6-1
Tire Inflation Pressures	6-1
Replacement Tires	6-2
Diagnosis and Testing - Pressure Gauges	6-2
Diagnosis and Testing Tread Wear Indicators	6-2
Diagnosis and Testing Tire Noise or Vibration	6-3
Repairing Leaks	6-3
Rotation	6-3
Wheels	6-4
Diagnosis and Testing - Wheel Inspection	6-4
Wheel Installation	6-4

TIRES AND WHEELS

DESCRIPTION

The GEM 825 uses steel wheels with a 4 bolt pattern, and tires in two different sizes as shown in the charts below:

Wheel Chart

	Two - Passenger	Four - Passenger, Short Bed Utility, Long Bed Utility
Construction	Steel	Steel
Diameter	10"	12"
Width	4"	4"
Offset	3 1/8"	2 1/8"
Bolt Pattern	4 on 4" circle	4 on 4" circle
Capacity	795 lb.	900 lb.

Tire Chart

	Two - Passenger	Four - Passenger, Short Bed Utility, Long Bed Utility
Size	205/50 - 10	165/70R - 12
Construction	Bias Ply	Steel Belt Radial
Ply Rating	4	4
Load Range	B	B
Rim Width	4.5"	4.5"
Max Section Width	8.5"	6.4"
Overall Diameter	17.7	21.4"
Maximum Load	795	795
Approx. Weight	10 lb.	13 lb.
Revs. Per Mile	1245	942

TIRES

Description

Tires are designed- and engineered for each specific vehicle. They provide the best overall performance for

normal operation. The ride and handling characteristics match the vehicle's requirements. With proper care they will give excellent reliability, traction, skid resistance, and tread life.

Driving habits have more effect on tire life than any other factor. Careful drivers will obtain in most cases, much greater mileage than severe use or careless drivers. A few of the driving habits, which will shorten the life of any tire, are:

- Rapid acceleration
- Severe brake applications
- Excessive speeds on turns
- Striking curbs and other obstacles

Radial-ply tires are more prone to irregular tread wear. It is important to follow the tire rotation interval. This will help to achieve a greater tread life.

RADIAL-PLY TIRES

Description

Radial-ply tires improve handling, tread life and ride quality, and decrease rolling resistance.

Radial-ply tires must always be used in sets of four. Radial-ply tires have the same load-carrying capacity as other types of tires of the same size. They also use the same recommended inflation pressures.

The use of oversized tires, either in the front or rear of the vehicle, can cause vehicle drive train failure.

The use of tires from different manufactures on the same vehicle is NOT recommended. The proper tire pressure should be maintained on all four tires.

TIRE INFLATION PRESSURES

Proper tire inflation pressure is essential to the safe and satisfactory operation of the vehicle. Under inflation will cause rapid shoulder wear, tire flexing, and possible tire failure.

Over inflation will cause rapid center wear and loss of the tire's ability to cushion shocks.

Both under- and over- inflation affect the stability of the vehicle and can produce a feeling of sluggish response or over-responsiveness

Unequal tire pressures can cause steering problems, resulting in loss of control of the vehicle.

For proper tire pressure specification, refer to the VIN/Certification Label at the left rear of the roof panel. The label also lists proper wheel and tire size for the vehicle. (See VIN/CERTIFICATION LABEL in INTRODUCTION section.)

Tire pressures have been chosen to provide safe operation, vehicle stability, and a smooth ride. Tire pressure should be checked cold once a month. Tire pressure decreases as the ambient temperature drops. Check tire pressure frequently when ambient temperature varies widely.

Specified tire inflation pressures are cold inflation pressures. The vehicle must sit for at least 3 hours to obtain the correct cold inflation pressure reading, or be driven less than one mile after sitting for 3 hours. Tire inflation pressures may increase from 2 to 6 pounds per square inch (psi) during operation. Do not reduce this normal pressure build-up.

WARNING!

Over or under-inflated tires can affect vehicle handling and tread wear. This may cause the tire to fail suddenly, resulting in loss of vehicle control.

REPLACEMENT TIRES

The original equipment tires provide a proper balance of many characteristics such as:

- Ride
- Noise
- Handling
- Durability
- Tread life
- Traction
- Rolling resistance
- Speed capability

It is recommended that tires equivalent to the original equipment tires be used when replacement is needed.

WARNING!

Do not use a tire size other than that specified. Improper size tires can cause vehicle components to wear out prematurely and may change the vehicle's ride, handling and steering behavior. In addition, it may affect the accuracy of the speedometer/odometer. Using tire sizes other than specified could cause loss of control, resulting in serious personal injury or death.

WARNING!

Never use a tire smaller than the size specified. Using a smaller tire could result in tire overloading and failure.

WARNING!

Overloading the tires is dangerous. Like under-inflation, overloading can cause tire failure. Use tires of the recommended load capacity, and never overload the vehicle.

DIAGNOSIS AND TESTING - PRESSURE GAUGES

A quality air pressure gauge is recommended to check tire pressure. After checking the air pressure, replace valve cap finger tight.

DIAGNOSIS AND TESTING - TREAD WEAR INDICATORS

Tread wear indicators are molded into the bottom of the tread grooves. When tread depth is 1.6 mm (1/16 in.), the tread wear indicators will appear as a 13 mm (1/2 in.) band.

Tire replacement is necessary when indicators appear in two or more grooves or if localized balding occurs.

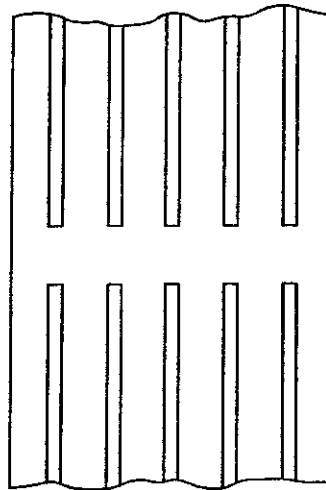
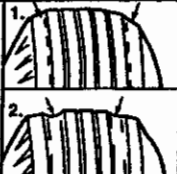





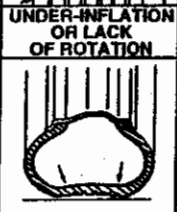
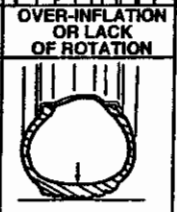
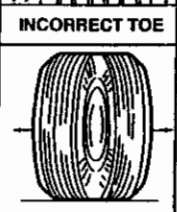
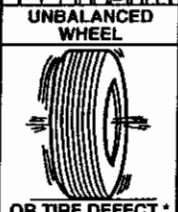

Figure 1 - Tread Wear Indicators

DIAGNOSIS AND TESTING - TIRE WEAR PATTERNS

Under inflation will cause wear on the shoulders of the tire. Over inflation will cause wear at the center of the tire. Excessive toe-in or toe-out causes wear on the tread edges and a feathered effect across the tread (Fig. 14).

CONDITION	RAPID WEAR AT SHOULDERS	RAPID WEAR AT CENTER	CRACKED TREADS	FEATHERED EDGE	BALD SPOTS	SCALLOPED WEAR
EFFECT						
CAUSE	UNDER-INFLATION OR LACK OF ROTATION 	OVER-INFLATION OR LACK OF ROTATION 	UNDER-INFLATION	INCORRECT TOE 	UNBALANCED WHEEL OR TIRE DEFECT* 	LACK OF ROTATION OF TIRES OR WORN OR OUT-OF-ALIGNMENT SUSPENSION.
CORRECTION	ADJUST PRESSURE TO SPECIFICATIONS WHEN TIRES ARE COOL ROTATE TIRES			ADJUST TOE-IN TO SPECIFICATIONS	DYNAMIC OR STATIC BALANCE WHEELS	ROTATE TIRES AND INSPECT SUSPENSION SEE GROUP 2

* HAVE TIRE INSPECTED FOR FURTHER USE.

Figure 2 - Tread Wear Chart

DIAGNOSIS AND TESTING - TIRE NOISE OR VIBRATION

Radial-ply tires are sensitive to force impulses caused by improper mounting, vibration, wheel defects, or possibly tire imbalance.

To find out if tires are causing the noise or vibration, drive the vehicle over a smooth road at varying speeds. Note the noise level during acceleration and deceleration. The motor and differential noises will change as speed varies, while the tire noise will usually remain constant.

REPAIRING LEAKS

For proper repairing, a radial tire must be removed from the wheel. Repairs should only be made if the defect, or puncture, is in the tread area (Fig. 15). The tire should be replaced if the puncture is located in the sidewall.

Deflate tire completely before removing the tire from the wheel. Use lubrication such as a mild soap solution when dismounting or mounting tire. Use tools free of burrs or sharp edges which could damage the tire or wheel rim.

Before mounting tire on wheel, make sure all rust is removed from the rim bead and repaint if necessary.

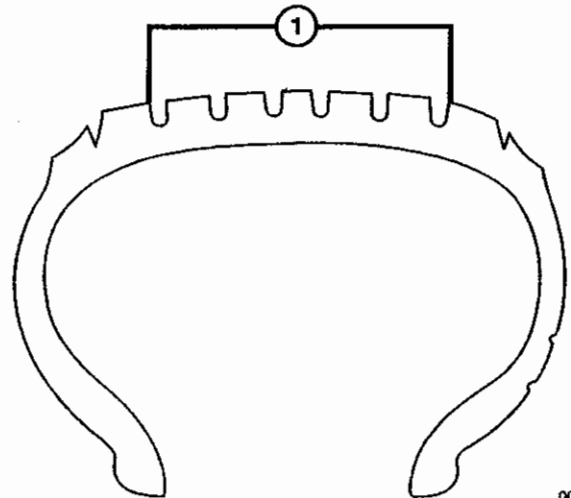

0063

Figure 3 - Tire Repair Area

1. Repairable area

ROTATION

Tires on the front and rear operate at different loads and perform different steering, driving, and braking functions. For these reasons they wear at unequal rates and tend to develop irregular wear patterns. Rotating the tires at regular intervals can reduce these effects. The benefits of tire rotation are:

- Increase tread life
- Maintain traction levels
- A smooth, quiet ride

The suggested method of tire rotation is (Fig. 3). Other rotation methods can be used, but they will not provide all the tire longevity benefits.

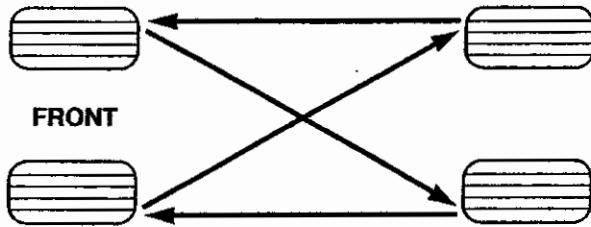

Figure 4 - Tire Rotation Pattern

WHEELS

Description

All models use stamped steel wheels. Every wheel has raised sections between the rim flanges and rim drop well called safety humps.

Initial inflation of the tire forces the bead over these raised sections. In case of rapid loss of air pressure, the raised sections help hold the tire on the wheel.

The wheel nuts are designed for this specific application. Do not use replacement nuts with a different design or lesser quality.

DIAGNOSIS AND TESTING - WHEEL INSPECTION

- Inspect wheels for:
 - Excessive run out
 - Dents or cracks
 - Damaged wheel lug nut holes
 - Air leaks from any area or surface of the rim

NOTE: Do not attempt to repair a wheel by hammering, heating or welding.

If a wheel is damaged an original equipment replacement wheel should be used. When obtaining replacement wheels, they should be equivalent in load carrying capacity. The diameter, width, offset and bolt circle of the wheel should be the same as the original wheel.

WARNING!

Failure to use equivalent replacement wheels may adversely affect the safety and handling of the vehicle. Used wheels are not recommended. The service history of the wheel may have included severe treatment or very high mileage. The rim could fail without warning.

WHEEL INSTALLATION

The wheel studs and nuts are designed for this vehicle. They must be replaced with equivalent parts. Do not use replacement parts of lesser quality or a substitute design.

Before installing the wheel, be sure to remove any build up of corrosion on the wheel mounting surfaces. Ensure wheels are installed with good metal contact. Improper installation could cause loosening of wheel nuts. This could affect the safety and handling of your vehicle.

To install the wheel, first position it properly on the mounting surface. All wheel nuts should then be tightened just snug. Gradually tighten them, in sequence, to the proper torque specification (see Figure 5)

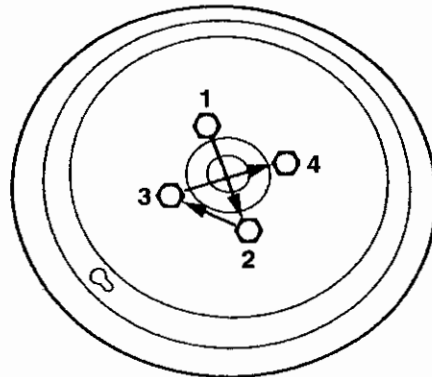

Figure 5 - Lug Nut Tightening Sequence

0064

CAUTION!

Never use oil or grease on studs or nuts.

WHEELS MUST BE REPLACED IF THEY:

- Have excessive run-out,
- Are bent or dented,
- Leak air through welds, or
- Have damaged bolt holes.

- Load carrying capacity,
- Diameter,
- Width,
- Offset,
- Mounting configuration.

Wheel repairs employing hammering, heating, or welding are not allowed.

Failure to use equivalent replacement wheels may affect the safety and handling of your vehicle. Replacement with used wheels is not recommended. Their service history may have included severe treatment.

Original equipment wheels are available through your dealer. Replacement wheels from any other source should be equivalent in:

TORQUE SPECIFICATIONS

DESCRIPTION	THREAD SIZE	Use Loctite® 242	INCH-POUNDS	FOOT-POUNDS
Wheel Lug Nuts	M10 x 1.5	NO	---	50

CONTENTS

Body Panels	7-1
Seat Belts	7-1
Two-Point Lap Belt	7-2
Three-Point Seat Belt	7-3
Body Side Panel	7-3
Body Back Panel	7-4
Seats	7-5
Bucket Seat	7-5
Mud Guard	7-6
Hood	7-6
Hood Latch Assembly - Old	7-7
Installation	7-7
Hood Latch Assembly - New	7-7
Dash	7-8
Dash Upper Panel	7-8
Dash Lower Panel	7-9
Spat	7-9
Linkspak / Swivelpak	7-10
Linkspak / Swivelpak Latch Assembly	7-11
Linkspak / Swivelpak Leg Pocket	7-12
Mirror-Center Rear View	7-12
Mirror-Side Rear View	7-12

BODY

BODY PANELS

Description

The GEM body panels are molded of white plastic. The hood, mud guards and spat come in a variety of colors.

Color Codes

The following chart identifies the available colors and the paint codes to match them.

	TRAVELER CODE	COLOR DESCRIPTION	PPG PAINT CODE
Basic Colors	B-Yellow	B-Yellow	PPG2696
	B-White	B-White	PPG91097
Custom Colors	C-Orange	C-Orange	
	C-Black	C-Black	
	C-B.H.Green	C-Bay Harbor Green	PPG43844
2001 Model Colors	01-Green	01-Green (Metallic)	M-5154U
2000 Model Colors	00-Blue	00-Royal Blue (Metallic)	DBC4830
	00-Red	00-Colorado Red	DCC4451-SC
	00-Silver	00-Gray Poly (Metallic)	DCC4854
	00-Green	00-Deep Green (Metallic)	DBC4735
1999 Model Colors	99-Green	99-Green	PPG2582
	99-Blue	99-Blue	PPG15231
	99-Red	99-Red	PPG72302

SEAT BELTS

Description

The GEM vehicles use automotive type seatbelts at all locations. The driver and front passenger positions on the four-passenger model have lap belts only. GEM vehicles use 3-point automotive seat belts on all models, except front bucket seats on four-passenger models (only two-point lap belts are available).

Diagnosis and Service

Seat belts should be inspected monthly for the following signs of wear:

1. Frayed edges on web.
2. Scores across web.
3. Obvious signs of wear on web at buckle.
4. Corrosion of any of metal parts or fasteners. If any of these signs are present, locate and correct cause, and replace seat belt assembly.

TWO-POINT LAP BELT

Description

The lap belt assembly consists of a belt/retractor assembly, a latch assembly and a mounting bracket. The mounting bracket is attached to the vehicle by the two (2) rear bucket seat mounting bolts.

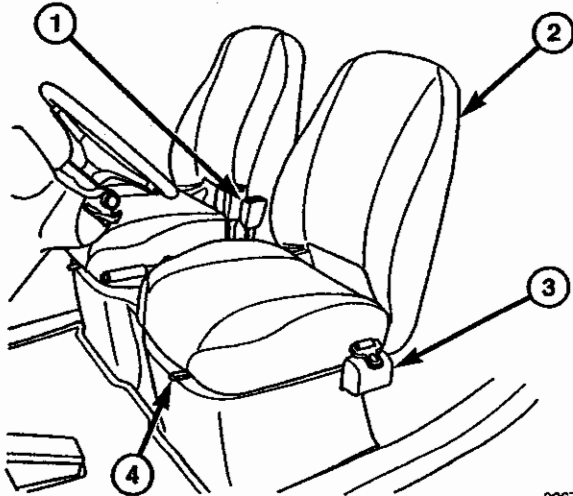

Figure 1 - Two Point Lap Belt

1. Seat Belt Latch Assembly
2. Bucket Seat
3. Belt and retractor assembly
4. Seat Adjuster Lever

Removal

1. From beneath vehicle, remove nuts from the four (4) bucket seat anchoring bolts.
2. Remove bucket seat assembly.
3. Remove seat belt bracket.
4. Remove bolt attaching lap belt/retractor assembly to seat belt bracket.
5. Remove lap belt/retractor assembly.
6. Remove bolt attaching lap belt latch assembly to seat belt bracket.
7. Remove lap belt latch assembly.

Installation

1. Position lap belt latch assembly at inboard end of seat belt bracket. Inboard end of bracket points UP. Attach with mounting bolt. Tighten to 60 foot-pounds.
2. Position lap belt/retractor assembly at outboard end of seat belt bracket. (Outboard end of bracket points DOWN. Attach with mounting bolt. Tighten to 60 foot-pounds.
3. Install two rear bucket seat mounting bolts through bucket seat assembly, then lap belt bracket.
4. Position bucket seat assembly and lap belt assembly on front seat support
5. From underneath vehicle, attach nuts to mounting bolts. Tighten nuts to 190 - 200 inch pounds.

TORQUE SPECIFICATIONS

DESCRIPTION	THREAD SIZE	Use Loctite® 242	INCH-POUNDS	FOOT-POUNDS
Seat Belt Latch Assembly to Bracket – Bucket Seat				60
Seat Belt Retractor to Bracket – Bucket Seat		NO	---	60

THREE-POINT SEAT BELT

Description

Three-point automotive shoulder/lap belts are used with bench seats. The seat belt is anchored to a flange at the lower outboard end of the seat back support frame. The seatbelt passes through a D-ring mounted at the upper outboard edge of the seat back support frame, into a retractor assembly mounted to the seat back frame approximately 6" below the D-ring. A seat belt latch assembly is mounted at the lower center of the seat back support frame.

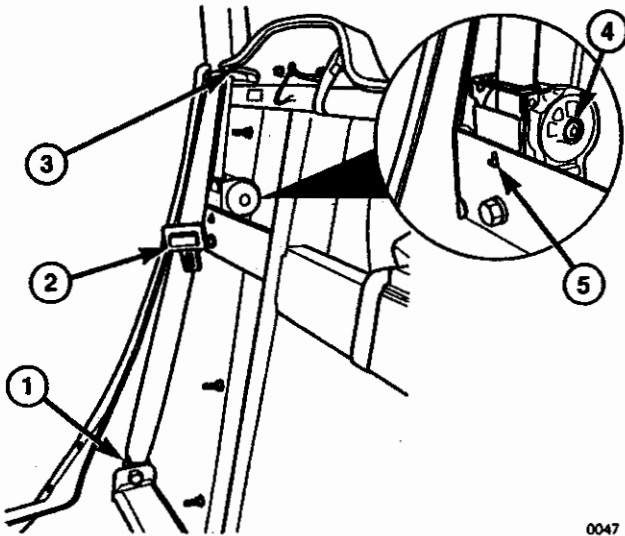

Figure 2 - Three-Point Seat Belt

0047

1. Seat belt anchor
2. Buckle assembly
3. D-Ring
4. Retractor
5. Locating tab

Removal

1. Remove lower seat cushion. (See SEATS in this section).
2. Remove taillight covers.
3. Remove seat back assembly. (See SEATS in this section).
4. Remove body side panel. (See BODY SIDE PANEL in this section).
5. Remove body back panel. (See BODY BACK PANEL in this section).
6. Remove bolt attaching D-ring to seat back support.
7. Remove bolt attaching retractor assembly to seat back support.
8. Remove bolt anchoring seat belt end to seat back support.

9. Remove seat belt assembly.
10. Remove bolt attaching seat belt latch assembly to seat back support.
11. Remove seat belt latch assembly.

Installation

1. Attach seat belt latch assembly to seat back support with mounting bolt. Tighten to 60 foot-pounds.
2. Attach D-ring to seat back support, making sure straight portion of D-ring faces forward. Tighten mounting bolt to 60 foot-pounds.
3. Attach seat belt/retractor assembly to seat back support. Tighten mounting bolt to 60 foot-pounds.

WARNING!

Tab on retractor assembly MUST engage locating hole on seat back support.

4. Feed seat belt end through D-ring, back to front, and attach to flange at lower outboard end of seat back support. Tighten mounting bolt to 60 foot-pounds.
5. Install body back panel. (See BODY BACK PANEL in this section.)
6. Install body side panels. (See BODY SIDE PANEL in this section.)
7. Install bench seat back. (See BENCH SEAT in this section.)
8. Install bench seat cushion
9. Install tail light covers.

BODY SIDE PANEL

Description

The body side panel is made of molded plastic and is mounted to the floor panel and back panel by rivets (old style) or phillips head bolts with nuts on the inside (new style).

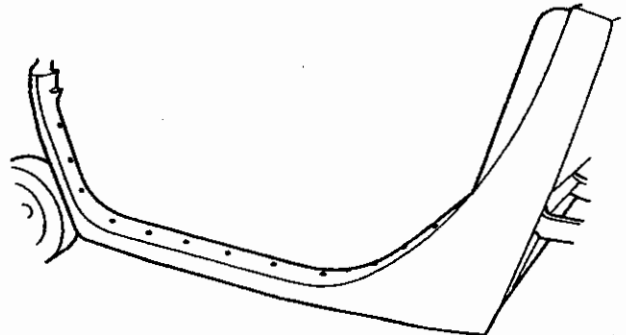

Figure 3 - Body Side Panel - LS - Typical (4-passenger shown)

0049

Removal

1. Remove upper and lower dash. (See DASH in this section).
2. Remove mudguard. (See MUDGUARDS in this section).
3. Remove spat. (See SPAT in this section).
4. Remove Rear Shock Mount Cover
5. Remove bench seat. (See BENCH SEAT in this section).
6. (Old style) Drill out center drives on rivets with a 1/8" drill bit. Remove rivets. (New style) Holding nuts with fingers or pliers, remove phillips head bolts. Be sure to retain the nuts.

NOTE: (Old Style) Make sure not to spin rivets, as they will leave marks on panels

7. While supporting the side panel, drill out the center drives on side panel rivets and remove.
8. Remove front upper attaching screw, and three lower attaching screws
9. Remove scuff guard (sill plate), if present.
10. Remove side panel.
11. If replacing panel, remove front and rear trim locks and transfer them to the new side panel.

Installation

1. Locate side panel on tub, making sure to match up holes and attaching back trim lock to back panel.
2. Position (optional) scuff guard over sill area of side panel.
3. Attach three lower screws with speed nuts on the back/bottom.
4. Attach front upper screws to hold body panel to frame.
5. Attach side panel to tub with phillips head bolts and nuts.
6. Attach side panel to body back panel with phillips head bolts and nuts.
7. Attach rear spat. (See SPAT in this section).
8. Attach rear shock mount cover. (See REAR SPRING/SHOCK ABSORBER MOUNT COVER in this section).
9. Attach bench seat back (See BENCH SEAT in this section).
10. Attach bench seat cushion. (See BENCH SEAT in this section).
11. Attach upper and lower dash. (See DASH in this section).
12. Attach mudguard. (See MUD GUARD in this section).

BODY BACK PANEL

Description

The body back panel is made of molded plastic. The two-passenger and four-passenger models have a cut-out to accommodate the Swivelpak/Linkspak latch assembly.

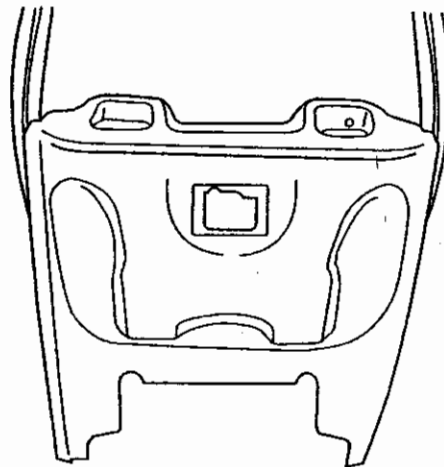

Figure 4 - Body Back Panel (with cutout)

Removal

1. Remove Swivelpak/Linkspak. (See SWIVELPAK/LINKSPAK in this section.)
2. Remove body side panels. (See BODY SIDE PANEL in this section.)
3. Remove Swivelpak/Linkspak handle. (See SWIVELPAK/LINKSPAK HANDLE in this section).
4. Remove two Tek screws (one on each side of panel)
5. Remove back panel

Installation

1. Position back panel.
2. Install two Tek screws (one on each side of panel)
3. Install Swivelpak/Linkspak handle, adjust as necessary. (See SWIVELPAK/LINKSPAK HANDLE ADJUSTMENT in this section.)
4. Install body side panels. (See BODY SIDE PANEL in this section.)
5. Install Swivelpak/Linkspak. (See SWIVELPAK/LINKSPAK in this section.)

SEATS

Description

The GEM vehicles utilize bench seats in all models. The four-passenger model has bucket seats in the driver and front passenger positions and the bench seat in the rear. **BENCH SEAT Description** The bench seat is comprised of a seat cushion and a seat back. The cushion is attached to the raised portion of the floor panel by a friction latch consisting of a male probe mounted on the seat cushion that mates to a female grommet mounted to the seat support. A hand hold is attached to each outboard end of the seat cushion. The seat back is attached to the back panel and seat back support by screws through the tail lamp assemblies and at the bottom of the seat back.

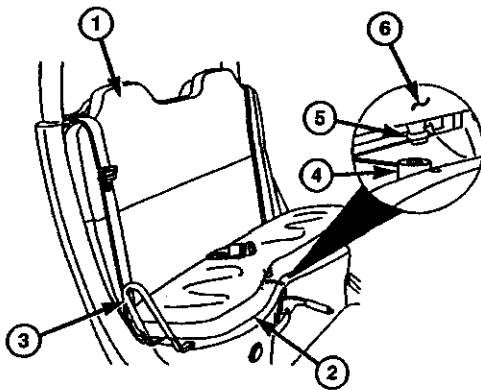

Figure 5 - Bench Seat - new style

- | | |
|--------------------------|----------------------------|
| 1. Bench seat back | 2. Bench seat cushion |
| 3. Hand hold | 4. Friction latch (female) |
| 5. Friction latch (male) | 6. Seat cushion |

Removal

- (Old style) Remove (2) knurled knob bolts. (New style) Pull up on front edge of seat cushion until friction latch is disengaged.
- Lift seat cushion up and away to remove.
- Remove tail light lenses.
- Remove (4) Phillips screws attaching seat back to back panel. These screws are located at the top of the tail light lamp reflectors, two on each side.
- Remove the two TEK screws (located on the lower plywood section of the seat back).
- Remove bench seat back.

Installation

- Position bench seat back against upper seat support frame.
- Install (2) TEK screws through lower plywood section of seat back into seat back support frame.
- Install (4) Phillips head screws through upper holes of tail lamp reflectors into seat back.

- Replace tail light lenses.

- (Old style) Position bench seat cushion and attach with (2) knurled knob bolts. (New style) Position bench seat cushion and push down to attach.

BUCKET SEAT

Description

The driver and front passenger seats in the four-passenger model are bucket seats. Each seat assembly consists of a seat cushion, built-in seat back and integral hand hold on outboard side of the cushion. The seat is adjustable. A handle under the front of the seat cushion releases a latch, allowing the seat to move forward or backward on two tracks.

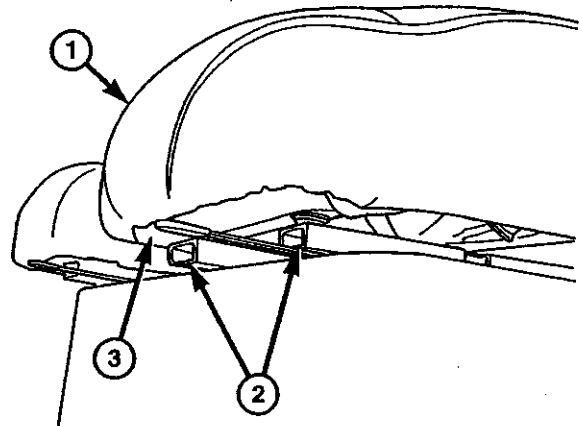

Figure 6 - Bucket Seat Adjuster

- Bucket seat
- Adjuster rails
- Adjusting lever

Removal

- From beneath vehicle, remove nuts from the (4) bucket seat anchoring bolts.
- Remove bucket seat assembly.

Installation

- Position bucket seat assembly over seat belt bracket, aligning rear mounting holes of seat over mounting holes of seat belt bracket.
- Insert (4) mounting bolts through bucket seat track, seat belt bracket into mounting holes in raised front seat portion of floor panel.
- From underneath vehicle, attach lock washers and nuts to mounting bolts.

MUD GUARD

Description

The mud guards are color keyed to match the hood. They are attached to the body side panel to form the trailing portion of the front fenders.

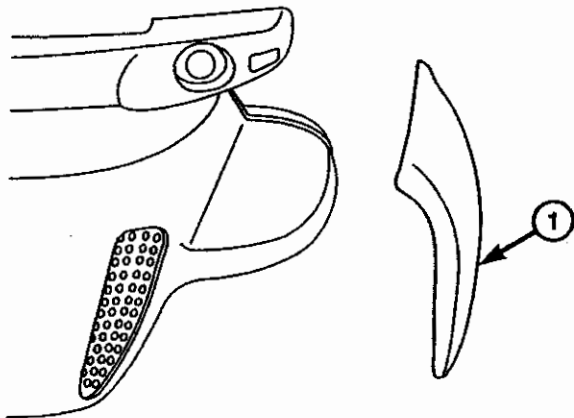

0052

Figure 7 - Mud Guard (Typical)

1. Mud Guard LS

Removal

- 1) Remove two screws and speed nuts attaching mud guard to body side panel.
- 2) Remove mud-guard.

Installation

1. With hood closed, position mud guard against body side panel so that the mud guard forms a clean line and fit with the fender portion of the hood assembly.
2. Using a hand clamp to maintain position of the mud guard
3. If installing a new mud guard, drill (2) 3/16" holes through mud guard and body side panel. (Use old mud guard to determine hole locations).
4. Attach with Phillips screws and speed nuts.

HOOD

Description

The hood assembly forms the hood and upper part of the front fenders. The head lamps and turn signal lamps are mounted in the hood. The hood is attached by hinges to

the front suspension support frame. On newer models, a latch at the center of the upper edge of the hood holds it secured when hood is closed. Older models use two (2) knurled knob bolts, one on each side, to secure the hood when closed. A hood strap prevents the hood from opening too far.

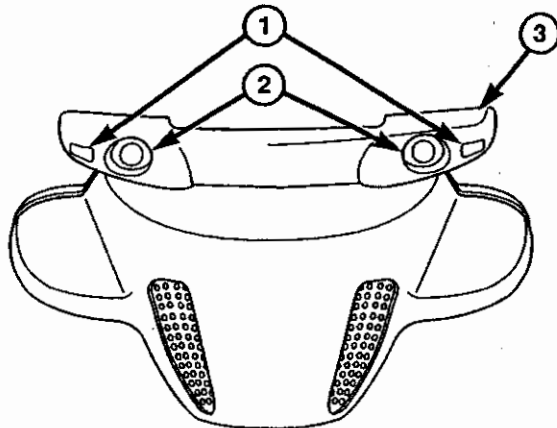

0051

Figure 8 - Hood (Front View)

1. Turn signal assemblies
2. Headlamp assemblies
3. Hood

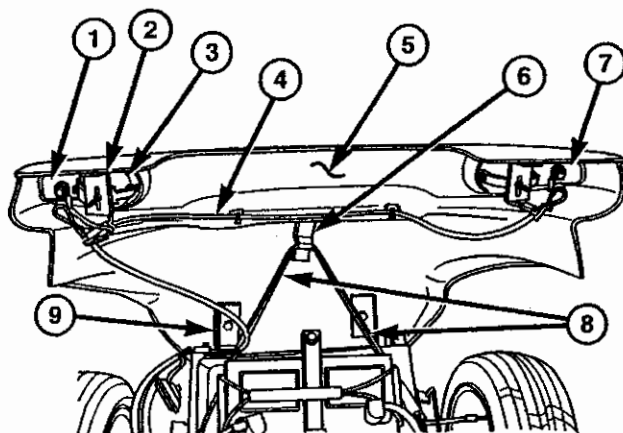

0135

Figure 9 - Hood (Rear View)

1. Left turn signal lamp assembly
2. Headlamp mounting bracket(s)
3. Headlamp assembly(s)
4. Headlamp wiring harness
5. Hood
6. Hood strap bracket
7. Right turn signal lamp assembly
8. Hood Strap
9. Hood hinge bracket(s)

Removal

1. Open hood.
2. While supporting hood, remove one of the screws that attach the hood strap to the front suspension frame, then pull strap through strap bracket on hood.
3. Remove hinge bracket mounting bolts.
4. Remove hood.

Installation

1. While supporting hood, attach hinge brackets to front suspension frame with mounting bolts. Bolts should be loose enough to allow adjustment of hood for fit, but tight enough to hold hood in adjusted position.
2. Thread hood strap through bracket on hood, then fasten strap ends to front suspension frame.
3. Adjust hood latch mounting bracket until latch is properly aligned with striker plate on hood.
4. Close hood and latch.

NOTE: Adjustment of hood for proper fit can only be made at the lower hood bracket. 5. Move hood brackets forward or back until proper fit of hood is attained, then tighten hood bracket mounting bolts.

HOOD LATCH ASSEMBLY - OLD

Description

The old hood latch assembly consists of two (2) adjustable brackets, each mounted to either side of the lower windshield support. The upper flat portion of each bracket is drilled and tapped to receive a knurled knob bolt that passes through holes located at the upper trailing edge of the hood.

Operation

To unlatch the hood, unscrew each knurled knob bolt until it is free of the bracket mounted on the lower windshield support. Pivot the hood forward. To latch the hood, thread each knurled knob bolt into the threaded hole on each mounting bracket and tighten.

Removal

1. Open hood.
2. Remove upper dash panel (See DASH in this section).
3. Remove bolts attaching mounting brackets to windshield lower support.
4. Remove mounting brackets.

INSTALLATION

1. Install mounting brackets to lower windshield support, tightening bolts just snug enough to maintain position, but loose enough to allow adjustment of bracket position.
2. Adjust mounting brackets until threaded holes are aligned with holes on hood.
3. Tighten bolts to secure mounting brackets in place.

HOOD LATCH ASSEMBLY - NEW

Description

The new hood latch assembly consists of an adjustable bracket, mounted to the center of the lower windshield support, holding a striker plate and an eccentrically pivoting latch handle mounted to the center of the hood trailing edge.

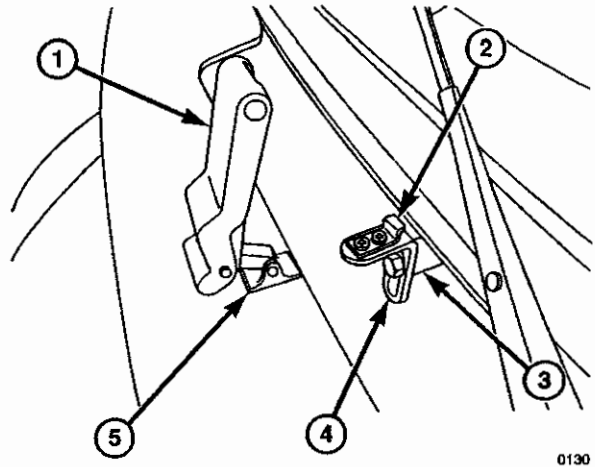

Figure 10 - Hood Latch Assembly (Open)

1. Hood latch
2. Latch striker
3. Striker mounting bolt/bushing
4. Striker bracket (adjustable)
5. Hood latch mounting bracket

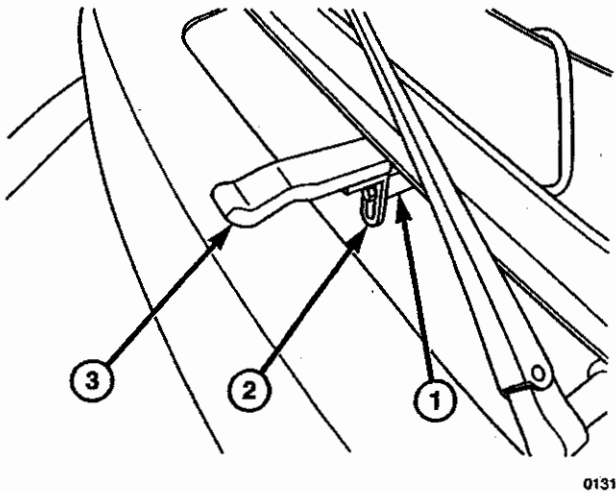

Figure 11 - Hood Latch Assembly (Closed)

1. Hood latch
2. Striker bracket (adjustable)
3. Striker mounting bolt/bushing

Operation

To unlatch the hood, pull up on leading end of latch handle to release tension on the striker plate, allowing disengagement of the striker. To latch the hood, engage handle on striker plate, then press down on leading end of handle to lock in place.

Removal

5. Open hood.
6. Remove (2) Phillips head screws attaching latch to hood.
7. Remove latch.
8. Remove upper dash panel (See DASH in this section).
9. Remove bolt attaching mounting bracket to windshield lower support.
10. Remove mounting bracket and bushing.

Disassembly

1. Remove (2) Phillips head screws attaching striker plate to mounting bracket.
2. Remove striker.

Assembly

1. Position striker on mounting bracket.
2. Attach with (2) Phillips head machine screws, lock washers and nuts.

Installation

4. Position latch on hood and attach with Phillips head screws, lock washer and nuts.
5. Install mounting bolt through lower windshield support from inside vehicle.
6. Insert bushing, then mounting bracket over mounting bolt and attach with locking nut just snug.
7. Adjust mounting bracket until striker plate is properly aligned with latch handle on hood.

CAUTION

Striker must be aligned vertically so that latch handle is horizontal when locked. If striker is too low or too high, hood may come unlatched when driving over rough surfaces.

8. Tighten mounting bolt to secure latch assembly in place.

DASH

Description

The dash consists of an upper panel assembly and a lower panel assembly. Inside the dash is located the battery charger and electronic control module (ECM).

DASH UPPER PANEL

Description

The upper dash panel is constructed of molded plastic. It contains cup holders for both driver and passenger sides, and a locking glove compartment in the center. The panel is secured by two (2) Phillips head screws through the lower windshield support, and by Velcro(r) strips where it mates with lower dash panel.

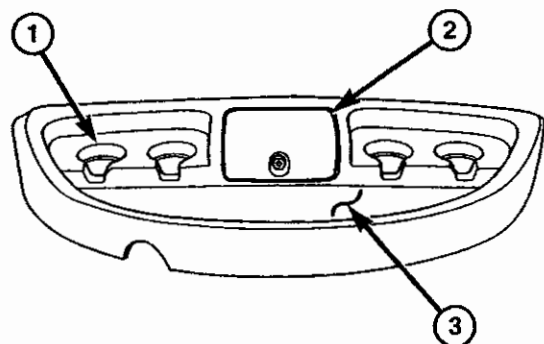

Figure 12 - Upper Dash Panel

1. Molded cup holder(s)
2. Locking glove box door
3. Storage tray

Removal

1. Open hood.
2. Remove the two Phillips head screws located immediately below windshield.
3. Lift upper dash assembly out, taking care to disconnect electrical hookups, if any.

Installation

1. Re-connect electrical hookups, if any.
2. Position upper dash assembly on lower dash assembly.
3. Attach upper dash to lower windshield support with two Phillips head screws.

NOTE: Take care not to cross-thread bolts, or jack nuts on dash panel will strip.

4. Close hood.

DASH LOWER PANEL

Description

The lower dash panel is constructed of molded plastic. It is secured in place by tabs fitting into slots in the floor panel, and (3) TEK screws into the dash support frame.

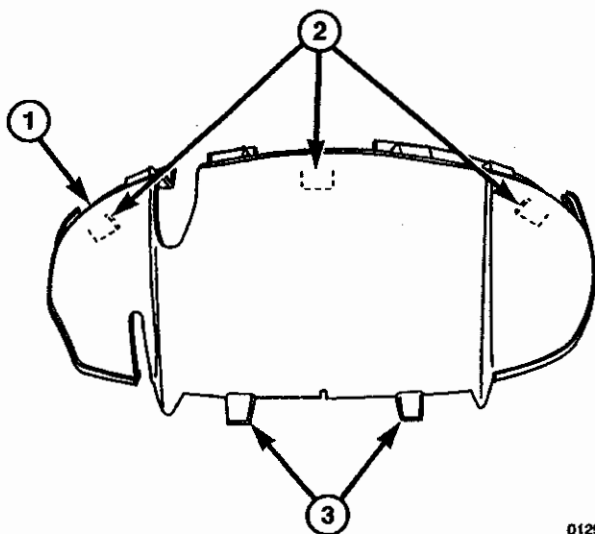

0129

Figure 13 - Lower Dash Panel

1. Lower dash panel
2. Upper mounting tabs
3. Floor tabs

Removal

1. Remove upper dash panel.
2. Locate and remove the (3) 3/8" Tek screws on the top surface mounting tabs.
3. Slowly lift lower dash panel out, then up until lower tabs are clear of the slots in the floor pan.

NOTE: Take care not to scratch steering column/instrument pod covers.

Installation

1. Insert panel lower tabs into slots in floor pan, then slowly lower and rock lower panel forward into place.

NOTE: Take care not to scratch steering column/instrument pod covers.

2. Install the (3) 3/8" Tek screws through the mounting tabs into the upper dash support frame.
3. Install upper dash panel.

SPAT

Description

A Spat is an assembly that acts as fenders over the rear wheels of the 2-passenger and 4-passenger vehicles. It is color keyed to match hood color.

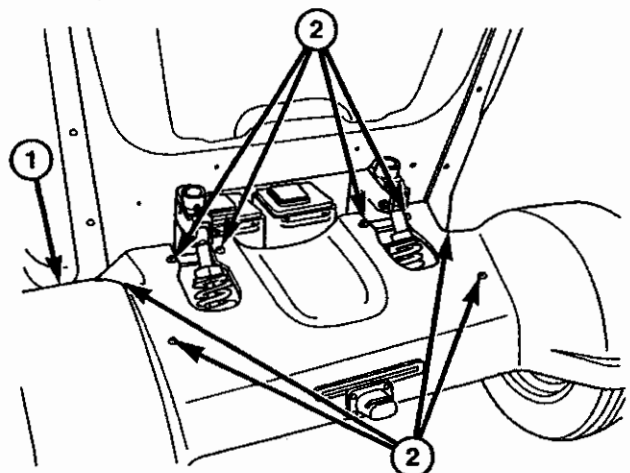

0053

Figure 14 - Spat

1. Spat
2. Phillips head mounting bolts (8)

Removal

1. Remove rear shock absorber mount cover.
2. If equipped with license plate bracket.
 - a) Disconnect ground wire attached to upper license plate bracket.
 - b) Remove bench seat cushion .
 - c) Follow license plate hot wire to connector located under bench seat cushion, above rear batteries, and disconnect.
3. Remove (4) hex head bolts and (4) Phillips head bolts that attach spat to mounting brackets.
4. Carefully remove spat.

INSTALLATION

1. Carefully position spat on vehicle.
2. Attach with (4) hex head bolts and (4) Phillips head bolts.

NOTE: The hex head bolts are used where they will be hidden by the rear shock absorber mount cover, and the Phillips head bolts are used at all exposed locations.

3. If vehicle is equipped with license plate bracket,
 - a) re-connect ground wire to upper license plate mounting bolt.
 - b) Route power wire over rear suspension frame to connector above rear batteries and connect.
4. Replace bench seat cushion.
5. Replace rear shock absorber mount cover.

LINKSPAK/SWIVELPAK

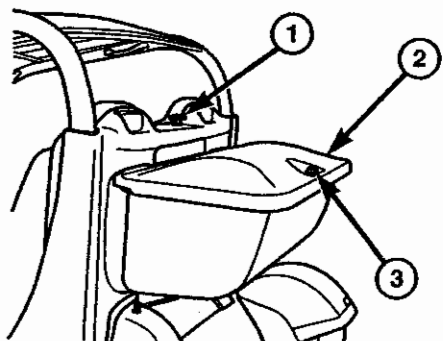
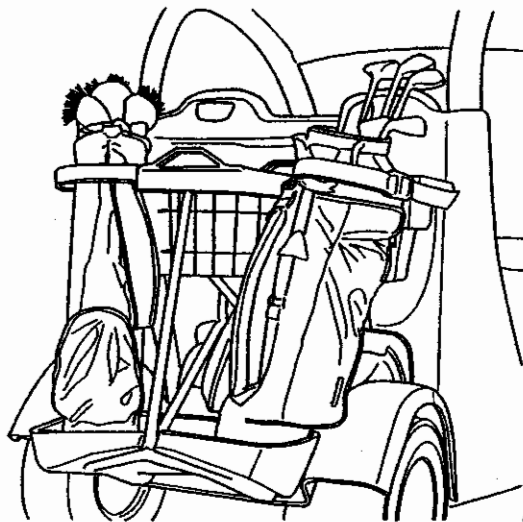

Figure 15 - SWIVELPAK

1. Latch handle 2. Swivel pak lid 3. Lid lock



0082

Figure 16 - LINKSPAK (clubs not included)

DESCRIPTION

The LINKSPAK is a unit designed to carry two sets of golf clubs. The SWIVELPAK is a molded plastic box with a hinged locking lid. Both are used on the two and four-passenger models. They are not available on the short bed or long bed utility models. All four have two legs that fit into pockets mounted on each frame rail. Each attaches to a locking latch assembly mounted at the top of the body back panel.

Removal

1. Use key to unlock the latch handle
2. Unlatch unit by turning handle counter-clockwise.
3. While supporting unit, pull Velcro strap at latch mechanism free of itself, and pull through bracket on unit.
4. Lift unit up to free legs from pockets and remove.

Installation

1. Set unit legs in pockets.
2. While supporting unit, thread Velcro strap, from the underside, through bracket on unit, then press it onto itself.
3. Rock unit forward until latch is engaged.

LINKSPAK/SWIVELPAK LATCH ASSEMBLY

Description

The pack latch assembly consists of a locking handle connected to a latch by threaded rods and a turnbuckle. The handle is mounted to the top of the body back panel. The latch is mounted to a plate that, in turn, is mounted to the bench seat back/body back panel support frame.

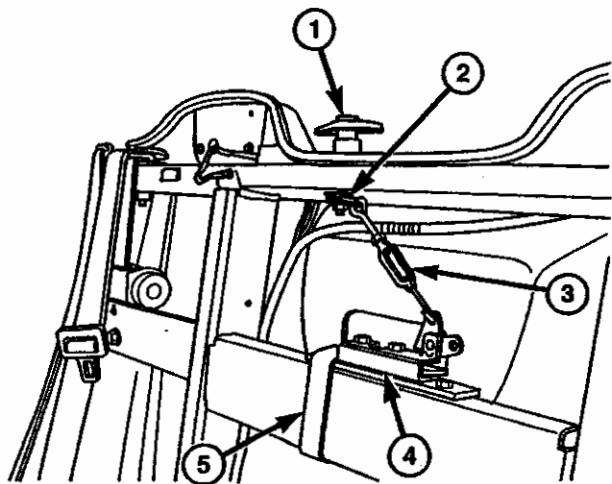

0055

Figure 17 - LINKSPAK/SWIVELPAK Latch Assembly

1. Locking handle
2. Turnbuckle bracket
3. Turnbuckle
4. Latch assembly
5. Velcro(r) safety strap

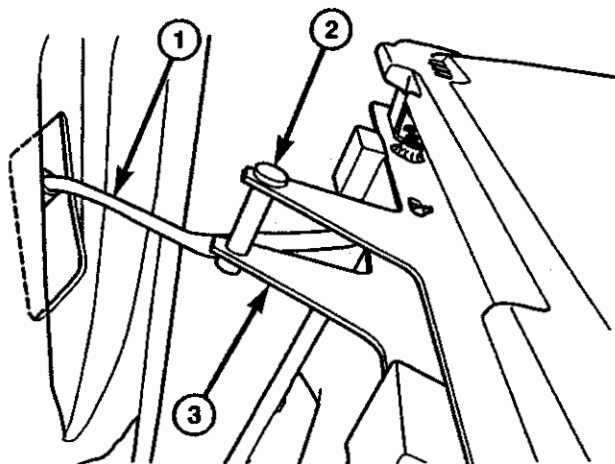

0136

Figure 18 - LINKSPAK/SWIVELPAK Striker Assembly

1. Velcro(r) safety strap
2. Latch striker
3. Latch striker bracket

Operation

The keyed locking mechanism in the handle prevents unauthorized unlatching of the pack unit for removal. When unlocked, turning the handle pulls on the threaded rods and turnbuckle to release the latch. Pushing the latch bracket on the pack unit into the latch mechanism causes it to close.

Adjustment

When turning the latch handle, there should be little or no play detected before the latching mechanism disengages the latch bar. Excessive play can result in the latching mechanism failing to disengage when the handle is turned. If the latching mechanism is not properly lined up with the latch bracket on the pack unit, it may be difficult or impossible to engage and lock the unit in place.

To adjust the play in the latch handle:

1. Remove bench seat cushion and back. (See BENCH SEAT in this section).
2. Rotate turnbuckle until play is sufficiently reduced.

To adjust latch alignment:

1. Remove bench seat cushion and back. (See BENCH SEAT in this section).
2. Loosen the (2) bolts attaching latching mechanism to the mounting plate.
3. Adjust latch assembly from side to side until proper alignment is attained.
4. Tighten mounting bolts.
5. Install bench seat.

Removal

1. Remove screw that attaches small bracket from turnbuckle to shaft handle. Remove two (2) screws that attach handle to back panel and remove handle.
2. Remove bench seat. (See BENCH SEAT in this section).
3. Remove small screw that attaches the turnbuckle assembly bracket to the handle, then dis-engage bracket from handle.
4. Remove (2) screws attaching handle assembly to body back panel.
5. Remove handle.
6. Remove (4) self-drilling screws attaching the latch mounting bracket to the seat back/body back panel support frame, remove latch assembly.

Installation

1. Position latch mounting plate on seat back/body back panel support frame and install (4) self-drilling screws.
2. Insert latch handle into body back panel, and install mounting screws.
3. Attach turnbuckle bracket to handle with screw.

NOTE: End of turnbuckle bracket (where threaded eye-bolt is attached) must be aligned toward latching mechanism.

4. Adjust latch mechanism position for proper alignment.
5. Adjust turnbuckle for proper play in handle.
6. Install bench seat back and cushion.

LINKSPAK/SWIVELPAK LEG POCKET

Description

The LINKSPAK/SWIVELPAK has two legs that fit into pockets mounted on each frame rail.

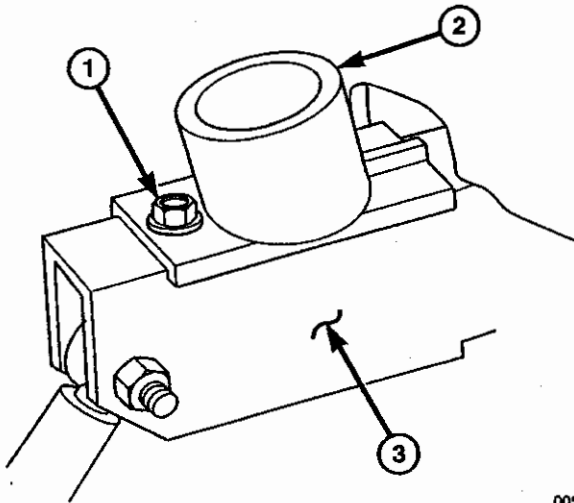

Figure 19 - LINKSPAK/SWIVELPAK Leg Pocket

1. Mounting bolt
2. Pocket
3. Frame rail

Removal

1. Remove Linkspak or Swivelpak.
2. Remove (2) bolts attaching pocket to upper rear frame rail.
3. Remove pocket.

Installation

1. Position pocket on upper rear frame rail.
2. Install (2) mounting bolts.
3. Install Linkspak or Swivelpak.

MIRROR - CENTER REAR VIEW

Description

The center rear view mirror assembly is mounted in the center of the upper windshield support. It is not serviceable and is replaced as a unit.

Removal

1. Remove the (2) Phillips head screws at either end of the mounting bracket.
2. Remove the Phillips head screw in the center of the mounting bracket.
3. Remove the mirror assembly.

Installation

1. POSITION MIRROR ASSEMBLY ON UPPER WINDSHIELD SUPPORT.
2. Install short (3/8") Phillips head screw in center hole of mounting bracket.
3. Install (2) long (3/4") Phillips head screws in either end holes of mounting bracket.

MIRROR - SIDE REAR VIEW

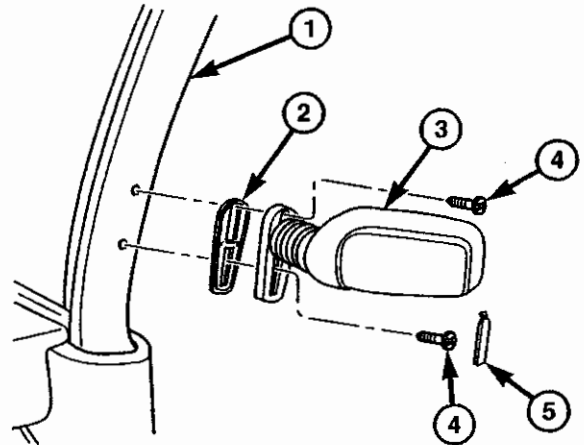

Figure 21 - Side Rear View Mirror (typical - LH shown)

1. Roof rail
2. Mounting gasket
3. Mirror assembly
4. Screws - mounting, phillips-head
5. Screw cover plate

Description

A driver's side rear view mirror is standard on all vehicles. Passenger side mirrors are optional. Side mounted rear view mirrors are attached to the front portion of the roof rail. If vehicle is ordered with optional hard doors, the mirrors are mounted on the doors. Damaged mirrors must be replaced as they are not serviceable.

Removal

1. Using small screwdriver, pry out lower screw cover on base of mirror.
2. Remove the two (2) phillips-head screws attaching mirror to roof rail/door.
3. Remove mirror assembly and mounting gasket.

Installation

1. Mount mirror and gasket to roof rail/door with phillips-head screws.
2. Replace screw cover.

WORK INDEX

accelerator foot pedal	5-4, 42
accelerator pedal	3-2, 5-6, 7, 8, 11, 12, 19, 20
Accelerator Potentiometer	5-11
Accessory System	5-2, 3, 8, 21, 27, 28, 29
Accumulated Miles	5-26
Actuator lever	4-7, 8, 11, 12
Adjuster rails	7-5
alignment	2-2, 3, 4, 14, 15, 7-11, 12
Backing plate	4-5, 6, 7
batteries	0-2, 4, 3-2, 4-10, 5-3, 4, 8, 10, 12, 13, 14, 15, 16, 17, 18, 27, 7-10
battery charger	5-3, 4, 8, 9, 10, 18, 19, 20, 22, 44, 46, 7-8
Battery Discharge Indicator	5-4, 6, 8, 20, 25, 26, 40, 42
Battery fluid	5-13
battery temperature	5-3
BDI	5-4, 6, 8, 10, 18, 19, 25, 26, 27, 40, 41
Belt and retractor assembly	7-2
bench seat	0-2, 3, 3-3, 4-10, 12, 5-2, 17, 24, 7-3, 4, 5, 10, 11, 12
bleed screws	4-3
body back panel	7-3, 4, 10, 11, 12
body panels	5-11, 12, 29, 7-1
body side panel	0-5, 7-3, 4, 6
boot	2-3, 4, 3-2, 3, 4, 5, 4-10, 11
BRAKE BLEEDING	2-7, 16, 4-3, 4, 6, 8, 9
brake drum	4-2, 3, 4, 5, 7, 11
brake fluid	0-4, 2-8, 4-2, 3, 4, 5, 7, 9
brake hoses	4-3
brake light switch	4-2, 8, 9
brake lights	0-4, 5-21, 27
brake line	0-3, 4, 2-3, 5, 7, 8, 9, 16, 17, 18, 4-2, 3, 5, 6, 7, 8, 9
brake pedal, 1"	-
BRAKE SYSTEM	0-4, 4-2, 3
Bucket Seat	0-3, 7-1, 2, 5
bushings	2-5, 6, 7, 8
Cable mounting bracket	4-11
Charge Receptacle	4-10, 5-4, 18
Charge Status Light	5-4, 25
cold tire pressure	0-2
colors	7-1
control arm	0-3, 5, 2-5, 7, 10, 18, 3-6
cup holders	7-8
dash	0-3, 2-5, 13, 14, 4-8, 9, 5-8, 11, 18, 19, 20, 21, 22, 26, 29, 7-4, 7, 8, 9
DC Motor	5-4, 27
DC-DC Converter	5-20, 21, 23
differential	0-3, 4, 2-5, 3-2, 3, 5, 6, 7, 5-23, 24, 6-3
direction switches	5-4
directional indicators	5-21, 27, 28
drive shafts	3-2
Drive System	5-2, 3, 4, 6, 7, 20, 27
drivetrain	0-5, 3-2, 5-23
drum brakes	2-8, 4-2, 3
ELECTRICAL	2-13, 3-6, 4-10, 11, 5-2, 5, 8, 11, 13, 15, 17, 19, 20, 21, 22, 23, 29, 7-9

WORK INDEX

electronic control module	7-8
Error Codes	5-4, 6, 8, 20, 22, 26, 27
fasteners	forward, 0-3, 2-5, 8, 7-1
Fault Code Display	5-26
Foot Brake Pedal	5-11
frame	0-3, 4, 2-5, 7, 8, 9, 13, 14, 15, 3-6, 7, 4-8, 9, 12, 5-7, 19, 7-3, 4, 5, 6, 7, 9, 10, 11, 12
front drum brake	2-17, 18, 4-2, 4
FRONT HARNESS	5-38, 39, 40
front suspension	0-3, 2-2, 5, 7, 18, 3-6, 7-6, 7
Fuse Box	5-29
fuse	5-3, 8, 20, 27, 28, 29, 42, 44, 45, 46,
gearbox	3-2
Gross Front and Rear Axle Ratings	0-2
Gross Vehicle Weight Rating	0-2
half shaft	0-3, 2-5, 7, 16, 17, 18, 3-2, 3, 4, 5, 6, 7, 4-5, 6
HEAD LIGHT HARNESS	5-38
headlights	0-4, 5-7, 20, 21, 27, 28, 29, 40,
heater	5-17, 27
hinges	7-6
hoisting	0-4, 5
hood latch assembly	7-7, 8
Hood Strap	7-6, 7
hood	4-9, 5-12, 29, 7-1, 6, 7, 8, 9
Horn Button	5-4, 25, 27
horn	0-4, 5-4, 8, 21, 25, 27, 28, 29, 39, 40
hub cap	2-7, 3-7
hydraulic brake system	4-2
inboard boot	3-4, 5
"INSTRUMENT PANEL HARNESS, 55"	-
instrument pod	2-11, 13, 5-4, 6, 25, 26, 27, 29, 7-9
introduction	4-5, 7, 6-2
jack stands	0-5, 2-8, 13, 14, 16, 4-7, 5-24
jacking	0-4, 4-5, 7
jam nut	2-15, 16, 4-11, 12
Jounce	2-6, 4-2
key switch	5-3, 4, 6, 9, 20, 21, 22, 25, 29
kingpins	2-2, 3, 10, 16, 17, 18
knuckle	0-3, 2-5, 6, 7, 9, 10, 15, 16, 17, 18, 4-5, 6, 8
latch assembly	0-4, 7-2, 3, 4, 7, 8, 10, 11
Latch handle	7-7, 8, 10, 11, 12
Latch striker	7-7, 11
Lid lock	7-10
lifting	0-5, 5-13, 29
Light Switch	4-2, 8, 9, 5-4, 25, 29
Linkspak	7-4, 10, 11, 12
glove box door	7-9
lower dash	2-13, 4-8, 9, 5-8, 11, 19, 20, 21, 22, 29, 7-4, 8, 9
L-Turn Signal/Brake Warning Light	5-4, 25
lubricants	0-4, 2-6
lug nuts	0-3, 2-5, 7, 8, 9, 14, 15, 16, 17, 18, 3-3, 5, 7, 4-5, 6, 8, 5-24, 6-5
Magnet	5-8, 10, 23, 25

WORK INDEX

Main Contactor	5-4, 6, 7, 8, 9, 22, 42
MAIN HARNESS	5-, 41, 42, 43
maintenance	0-3, 4
master cylinder	0-3, 5, 2-5, 7, 9, 17, 18, 4-2, 4, 5, 6, 7, 8, 9
master disconnect	0-2, 3-3, 6, 7, 4-10, 11, 5-2, 4, 5, 8, 15, 17, 19, 20, 21, 22, 24
Master Disconnect Switch	3-3, 5-2, 4, 5, 8, 15, 17, 19, 20, 21, 22, 24
Mirror assembly	7-12, 13
motor	forward, 0-3, 4, 3-2, 6, 7, 5-3, 4, 6, 7, 8, 9, 10, 11, 18, 19, 20, 22, 23, 25, 27, 28, 29, 39, 42, 43, 44, 46, 6-3
Motor Controller	5-3, 4, 6, 7, 8, 9, 10, 11, 18, 19, 20, 22, 25, 42, 44, 46
MPH Speed Indicator	5-26
mud guards	7-1, 6
outboard boot	3-3, 4, 5
paint codes	7-1
park brake	2-3, 8, 9, 4-2, 7, 8, 10, 11, 12
park brake cables	2-8, 9, 4-2, 10, 11, 12
park brake lever	4-2, 7, 10, 11
pedal housing	5-11, 12
pinch bolt	0-3, 2-4, 5, 13, 14, 16, 17, 18
pinion	0-3, 2-5, 10, 11, 13, 14, 15, 3-2, 6, 5-23
POWER HARNESS	5-3, 28, 45, 46, 47
Power System	5-2, 3, 4, 6, 8, 10, 20, 21, 22, 23, 26
Pre-Alignment	2-2
Printed Wiring Board	5-11, 18, 19, 21, 22
PWB	5-9, 18, 19, 20, 21, 22, 28, 42, 43, 46
Rack and pinion steering gear	2-10, 14
Radial-ply tires	6-1, 3
radio	5-27
rear axle	0-2, 2-8, 9, 4-7, 8
rear drum brake	2-8, 9, 4-2
rear shock absorber mount cover	7-10
rear suspension	0-3, 2-5, 6, 8, 9, 4-12, 7-10
rear view mirror	7-12, 13
reservoir	4-2, 3, 4, 9
Retention pin clip(s)	4-5
Road/Turf Switch	5-4, 25
Roof rail	7-12, 13
R-Turn Signal/Seat Belt Warning Light	5-4, 25
safety strap	7-11
safety	0-2, 2-2, 5-13, 15, 19, 6-4, 5, 7-11
Schott Charger	5-18, 19, 39, 7-2
Seat Adjuster Lever	7-3, 4, 5, 11, 12
seat back	7-3
Seat belt anchor	0-4
Seat Belt Latch	0-3, 7-2, 3
seat cushion	0-2, 3-3, 4-12, 5-12, 17, 24, 7-3, 4, 5, 10, 11
seatbelts	7-1
shock absorber	0-3, 2-5, 6, 7, 8, 9, 16, 3-5, 6, 7, 7-4, 10
shoe retainer	4-5, 7
shoe retention pin(s)	4-5, 7
shoes	4-2, 3, 5, 6, 7, 8
Side Rear View Mirror	7-12, 13

WORK INDEX

spat.....	2-8, 4-11, 12, 7-1, 4, 9, 10
Specific Gravity.....	5-14, 15, 17, 18
spindle.....	2-14, 3-2, 3, 4, 5, 6, 7, 8, 5-25
Spring.....	2-5, 6, 7, 8, 9, 3-3, 5, 6, 4-5, 6, 7, 8, 5-11, 12, 7-4
spring/shock absorbers.....	2-8
Steering column.....	0-3, 2-3, 4, 5, 10, 13, 14, 15, 4-9, 5-29, 7-9
Steering gear.....	2-3, 4, 10, 11, 13, 14, 15, 3-6
Steering shaft.....	0-3, 2-4, 5, 11, 12, 13, 14, 3-6
steering system.....	2-2, 9, 10
steering wheel cover.....	2-11, 12
Steering Wheel Puller.....	2-11
Steering wheel.....	0-3, 2-4, 5, 10, 11, 12, 13, 14, 5-26, 29
Storage tray.....	7-9
Swivel pak lid.....	7-10
Swivelpak.....	7-4, 10, 11, 12
tachometer.....	5-4, 8, 10, 42, 44
Tail Light Harness.....	5-28, 46, 47
taillights.....	5-21, 27, 28
temperature sensor.....	5-3, 10, 39
Tie Rod.....	0-3, 2-4, 5, 7, 10, 14, 15, 16, 17, 18
tire pressure.....	0-2, 2-2, 3, 10, 6-1, 2
Tire Rotation.....	6-1, 3, 4
Tire size.....	0-2, 6-2
tires.....	0-2, 4, 2-2, 3, 4, 9, 10, 3-2, 4-2, 3, 6-1, 2, 3
Toe.....	2-3, 4, 14, 15, 6-3
toe-in.....	2-4, 14, 15, 6-3
torque specifications.....	0-3, 2-5, 6, 7, 9, 12, 14, 15, 16, 17, 18, 3-5, 7, 4-6, 8, 9, 12, 6-5, 7-2
turf switch.....	5-4, 5, 20, 25
Turn signal lever.....	5-4, 25, 27
upper dash.....	2-13, 4-9, 5-11, 22, 26, 29, 7-7, 8, 9
Vehicle Direction Switch.....	5-4, 25
Vehicle Identification Number.....	0-2
VIN.....	0-2, 2-2, 6, 14, 6-2
warning.....	0-2, 3, 5, 4-3, 10, 5-2, 4, 5, 13, 14, 15, 16, 17, 25, 6-2, 4, 7-3
wheel bearings.....	2-2, 3, 10, 4-3
wheel cylinder.....	2-17, 18, 4-2, 3, 5, 6, 7, 8
Wheel size.....	0-2
wheels.....	2-3, 4, 5, 6, 8, 10, 13, 14, 4-2, 4, 9, 10, 11, 12, 6-1, 4, 5, 7-9
Windshield Wiper Switch.....	5-4, 25
wipers.....	5-8, 22, 27, 28
Yoke.....	0-3, 2-5, 7, 10, 16, 17, 18
Zivan Charger.....	5-18, 19, 42
ZIVAN HARNESS.....	5-45



▶ Attach to your tax return.
▶ See instructions on back.

Name(s) shown on return

Identifying number

Part I Tentative Credit

Use a separate column for each vehicle. If you need more columns, use additional Forms 8834 and include the total on line 8.

	(a)	(b)	(c)	
1 Enter date vehicle placed in service (MM/DD/YYYY)	1 / /	/ /	/ /	
2 Cost of vehicle	2			
3 Section 179 expense deduction (see instructions)	3			
4 Subtract line 3 from line 2	4			
5 For a vehicle placed in service before 2004, multiply line 4 by 10% (.10). For a vehicle placed in service in 2004, multiply line 4 by 7.5% (.075) (see instructions).	5			
6 Maximum credit per vehicle. For a vehicle placed in service before 2004, enter \$4,000. For a vehicle placed in service in 2004, enter \$3,000 (see instructions)	6			
7 Enter the smaller of line 5 or line 6	7			
8 Add columns (a) through (c) on line 7				8
9 Qualified electric vehicle credits from pass-through entities: If you are a: Then enter the total electric vehicle credits from:				9
Shareholder Schedule K-1 (Form 1120S), lines 12d through 13				9
Partner Schedule K-1 (Form 1065), lines 12c through 13				
10 Add lines 8 and 9				10
11 Passive activity credits included on line 10 (see instructions)				11
12 Subtract line 11 from line 10				12
13 Passive activity credits allowed for 2003 (see instructions)				13
14 Tentative qualified electric vehicle credit. Add lines 12 and 13. ▶				14

Part II Allowable Credit

15 Regular tax before credits. • Individuals. Enter the amount from Form 1040, line 41. • Corporations. Enter the amount from Form 1120, Schedule J, line 3. • Other filers. Enter the regular tax before credits from your return.				15
16 Credits that reduce regular tax before the qualified electric vehicle credit:				16
a Foreign tax credit	16a			
b Credit for child and dependent care expenses (Form 2441, line 11)	16b			
c Credit for the elderly or the disabled (Schedule R (Form 1040), line 24)	16c			
d Education credits (Form 8863, line 18)	16d			
e Credit for qualified retirement savings contributions (Form 8880, line 14)	16e			
f Child tax credit (Form 1040, line 49)	16f			
g Mortgage interest credit (Form 8396, line 11)	16g			
h Adoption credit (Form 8839, line 18)	16h			
i District of Columbia first-time homebuyer credit (Form 8859, line 11)	16i			
j Possessions tax credit (Form 5735, line 17 or 27)	16j			
k Credit for fuel from a nonconventional source	16k			
l Add lines 16a through 16k				16l
17 Net regular tax. Subtract line 16l from line 15. If zero or less, do not file this form; you cannot claim this credit				17
18 Tentative minimum tax (see instructions). • Individuals. Enter the amount from Form 6251, line 33. • Corporations. Enter the amount from Form 4626, line 12. • Estates and trusts. Enter the amount from Form 1041, Schedule I, line 54.				18
19 Subtract line 18 from line 17. If zero or less, do not file this form; you cannot claim this credit				19
20 Qualified electric vehicle credit. Enter the smaller of line 14 or 19 here and on Form 1040, line 52; Form 1120, Schedule J, line 6c; Form 1041, Schedule G, line 2b; or the appropriate line of your return. If line 19 is smaller than line 14, see instructions ▶				20

General Instructions

Section references are to the Internal Revenue Code.

A Change To Note

For qualified electric vehicles placed in service in 2004, the credit is reduced by 25%.

Purpose of Form

Use Form 8834 to figure the credit for qualified electric vehicles placed in service during the tax year.

Amount of Credit

The credit for each qualified electric vehicle is:

- 10% of the vehicle's cost reduced by any section 179 deduction, up to a maximum credit of \$4,000, for each qualified electric vehicle placed in service before 2004, and
- 7.5% of the vehicle's cost reduced by any section 179 deduction, up to a maximum credit of \$3,000, for each qualified electric vehicle placed in service in 2004.

Qualified Electric Vehicle

A **qualified electric vehicle** is any motor vehicle that is:

- Manufactured primarily for use on public streets, roads, and highways, and has at least four wheels;
- Powered primarily by an electric motor drawing current from rechargeable batteries, fuel cells, or other portable sources of electrical current;
- Originally used by you; and
- Acquired for your own use and not for resale.

Exceptions. The qualified electric vehicle credit does not apply to vehicles that are:

- Operated exclusively on a rail or rails,
- Used primarily outside the United States,
- Used by a governmental unit or agency or any foreign person or entity, or
- Used by a tax-exempt organization (other than a section 521 farmers' cooperative) unless the property is used mainly in an unrelated trade or business taxed under section 511.

See section 50(b) for details and other exceptions that may apply.

Caution: Gasoline/electric hybrid vehicles that are not powered primarily by an electric motor are not qualified electric vehicles. These hybrid vehicles include the Honda Insight, Honda Civic Hybrid, and Toyota Prius. However, part of the cost of these vehicles (up to \$2,000 for a vehicle with a gross vehicle weight rating that does not exceed 10,000 pounds) may qualify for the deduction for clean-fuel vehicles, even if you do not use the vehicle for business purposes. For hybrid vehicles placed in service in 2004, the maximum clean-fuel vehicle deduction is reduced to \$1,500. See **Pub. 535, Business Expenses**, for more details.

Basis Reduction

Unless you elect not to take the credit, you must reduce the basis of each vehicle by the amount of the credit entered on line 7 for that vehicle.

Recapture of Credit

If the vehicle no longer qualifies for the credit within 3 years of the date you placed it in service, you must recapture part or all of the credit. Generally, no recapture occurs on the sale or other disposition of the vehicle (including a disposition resulting from an accident or other casualty). However, if the vehicle will be modified after you dispose of it so that it no

longer qualifies for the credit, the credit may be subject to recapture. See Pub. 535 for details.

Specific Instructions

Line 3

Enter any section 179 expense deduction you claimed for this vehicle from Part I of **Form 4562**, Depreciation and Amortization.

Lines 5 and 6

Do not claim the credit for a vehicle placed in service in 2004 unless you are a fiscal year taxpayer who placed the vehicle in service before the end of your 2003-2004 fiscal year.

Line 11

Enter the amount of any credits included on line 10 that are from a passive activity. Generally, a passive activity is a business activity in which you did not materially participate. Rental activities are generally passive activities, whether or not you materially participate. See **Form 8582-CR**, Passive Activity Credit Limitations, or **Form 8810**, Corporate Passive Activity Loss and Credit Limitations, for details.

Line 13

Enter the qualified electric vehicle passive activity credits allowed for 2003 from Form 8582-CR or Form 8810. See the instructions for the applicable form for more information.

Line 18

Although you may not owe alternative minimum tax (AMT), you generally must still figure the tentative minimum tax (TMT) to figure your credit. For a small corporation exempt from the AMT under section 55(e), enter zero. Otherwise, complete **and** attach the applicable AMT form or schedule and enter the TMT on line 18.

Line 20

If you cannot use part of the credit because of the tax liability limit, the unused credit is lost. The unused or excess credit cannot be carried back or forward to other tax years.

Paperwork Reduction Act Notice. We ask for the information on this form to carry out the Internal Revenue laws of the United States. You are required to give us the information. We need it to ensure that you are complying with these laws and to allow us to figure and collect the right amount of tax.

You are not required to provide the information requested on a form that is subject to the Paperwork Reduction Act unless the form displays a valid OMB control number. Books or records relating to a form or its instructions must be retained as long as their contents may become material in the administration of any Internal Revenue law. Generally, tax returns and return information are confidential, as required by section 6103.

The time needed to complete and file this form will vary depending on individual circumstances. The estimated average time is:

- Recordkeeping** 7 hr., 39 min.
- Learning about the law or the form** 30 min.
- Preparing, copying, assembling, and sending the form to the IRS** 39 min.

If you have comments concerning the accuracy of these time estimates or suggestions for making this form simpler, we would be happy to hear from you. See the instructions for the tax return with which this form is filed.



INTERIOR OPTIONS

www.gemcar.com



Alpine Stereo System

New Option for 2005!

[Factory MSRP \\$695](#)



Accessory Plug

12 volt adapter that can be used for cell phones, etc.. Protected by a 3 amp fuse.

[Factory MSRP \\$35](#)

[After market MSRP \\$95](#)



Dome Light

New Option for 2005!

[Factory MSRP \\$35](#)



Scuff Guards

Black plastic overlay for the protection of body panels when entering or exiting the vehicle.

2 - Passenger (set of 2)

[Factory MSRP \\$55](#)

[After market MSRP \\$155](#)

4 - Passenger (set of 4)

[Factory MSRP \\$75](#)

[After market MSRP \\$175](#)



Heater / Defroster

New Heater/Defroster system with two upper dash vents and one lower dash vent.

[Factory MSRP \\$395](#)

[After market MSRP \\$575](#)

EXTERIOR OPTIONS

www.gemcar.com

Exterior



Custom Wheels

Wheels come in chrome or aluminum, they feature a five point star design and add sophisticated appeal to the GEM.

10" Aluminum

[Factory MSRP \\$445](#)

[After market MSRP \\$495](#)

10" Chrome

[Factory MSRP \\$575](#)

[After market MSRP \\$645](#)

12" Aluminum

[Factory MSRP \\$495](#)

[After market MSRP \\$545](#)

12" Chrome

[Factory MSRP \\$595](#)

[After market MSRP \\$695](#)



Chrome Bumper

Chrome plated 3 mile per hour bumper mounts on front cross member. 2" X 19"

[Factory MSRP \\$115](#)

[After market MSRP \\$215](#)

CARGO/CARRIER OPTIONS

www.gemcar.com

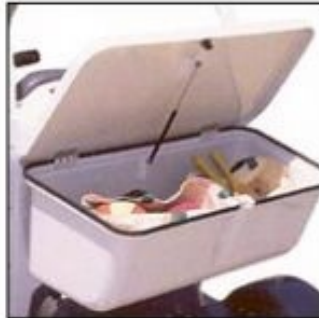

TrunkBack™

Detachable and lockable ABS plastic storage container with hinged top and drain holes. Approximately 33" X 16" X 15" deep.

[Factory MSRP \\$395](#)

[After market MSRP \\$525](#)



LinksBack™

Dual titles golf bag holder with easy access to golf clubs while providing two separate containers and a central basket for the variety of accessories used by the modern golfer.

[Factory MSRP \\$395](#)

[After market MSRP \\$525](#)



Long-back NEV Stake-back Kit

Three piece aluminum stake back package with pockets. Powder coated, easy to install and greatly enhances the ability to carry larger, lightweight cargo.

[Factory MSRP \\$495](#)

[After market MSRP \\$595](#)



Short-back NEV Stake-back Kit

Three piece aluminum stake back package with pockets. Powder coated, easy to install and greatly enhances the ability to carry larger, lightweight cargo.

[Factory MSRP \\$395](#)

[After market MSRP \\$495](#)

DOORS/ENCLOSURES OPTIONS

www.gemcar.com



Soft Weather Enclosure (2 pass)

Canvas enclosure for the doors and rear window. The soft doors open from the front and roll towards the back. Clips and slide rails mount the gray canvas. The rear window is mounted by Velcro.

[Factory MSRP \\$695](#)

[After market MSRP \\$795](#)



Soft Weather Enclosure (4 pass)

Pinstriped umbrella canvas enclosures for sides and rear window. The dark gray canvas is mounted by clips and slide rail. The rear window is mounted by Velcro.

[Factory MSRP \\$895](#)

[After market MSRP \\$995](#)



Hard Doors (2 pass)

Rigid white enclosures feature high-mounted removable hard doors with fully lowering windows.

[Factory MSRP \\$1595](#)

[After market MSRP \\$1895](#)



Hard Doors (4 pass)

Rigid white enclosures feature high-mounted removable hard doors with fully lowering windows. Available for in-factory orders of new 4 passenger GEM only.

[Factory MSRP \\$2595](#)

After market MSRP -
Not Available

MISCELLANEOUS OPTIONS

www.gemcar.com

Under the Hood



Gel Battery

A maintenance free alternative to the standard flooded lead acid battery. The gel battery offers a better charge time and more distance while remaining maintenance-free.

[Factory MSRP \\$395](#)

[After market MSRP \\$1595](#)



Windshield Washer Kit

Windshield washer kit comes with washer fluid tank and hook up, operates like a standard windshield washer system.

[Factory MSRP \\$75](#)

After market MSRP -
Not Available



Charging Cordset Kit

Charging cord comes equipped with a supplemental ground fault circuit interruption protector. Charging cord also comes with a bag for convenient storage.

[Factory MSRP \\$35](#)

[After market MSRP \\$45](#)

Q — How do I prepare my car for storage?

A — The biggest concern about storage is battery care. Always store batteries fully charged. If your car is stored in a cold climate, a fully charged battery will not freeze. Always store your car with the disconnect switch turned off. (Remove 48 GND battery cable for cars without a disconnect switch. Refer to operator's manual) The charger and controller have a 50 mA continuous draw. This seems small, but over a long period of time it adds up. Due to this, we suggest turning off the disconnect switch anytime the car will sit idle for one week or longer. Batteries have an inherent self discharge, also. If the car is being stored for several months, it should be charged once every two months. Simply turn the disconnect switch to the on position and plug in the charger. The charger will not be operational unless the disconnect switch is on. After the charger has cycled turn the switch back off again. There is no advantage to leaving the charger plugged in, as it will not automatically turn back on after the voltage goes down.

Q — If my batteries do go dead from storage, what do I do?

A — Due to a safety circuit in the charger, the charger will not turn on if the pack voltage is lower than 25-30 volts on a 48 volt car (about 40 volts for a 72 volts car). Turn off disconnect or remove 48 GND, and charge each battery individually with a 12 volt automotive type charger. Use a medium current (10-40 Amps) for about 30 minutes to 1 hour per battery. Once the pack voltage is high enough, turn on disconnect and plug in charger.

Q — While driving my 72 volt car, my Battery Discharge Indicator (BDI) shows a certain percentage, but after sitting a few minutes it goes up. Which do I go by?

A — The BDI looks at battery voltage under load. Each time the key is turned on, the BDI checks voltage. The voltage will look high until a load is on it, then it will drop down to where it last was. The reading while driving is more accurate.

Q — Can I wash my car with a pressure washer?

A — Yes, the exterior of the vehicle can be pressure washed. we recommend not spraying the dash area directly, since most of the electronics are under the dash.

Q — Can I wash my car with a pressure washer?

A — Yes, the exterior of the vehicle can be pressure washed. we recommend not spraying the dash area directly, since most of the electronics are under the dash.

Q — How often should I check the battery water?

A — This depends on the climate and the amount of use. Hot weather and heavy use increase the boil off. At a minimum we recommend checking it once a month. In very hot conditions, or under heavy use, once every two weeks is preferred. It is better to check too often then to not check it enough. Batteries can be damaged by not having enough electrolyte. The plates should be covered, but don't fill the cells too full. About 1/2 to 3/4 inch from the top is fine.

Q — What should I fill my batteries with?

A — It is best to use distilled water. Tap water contains too many minerals.







